

# Xonar DSX

## *7.1 PCIE Audio card*

# User manual

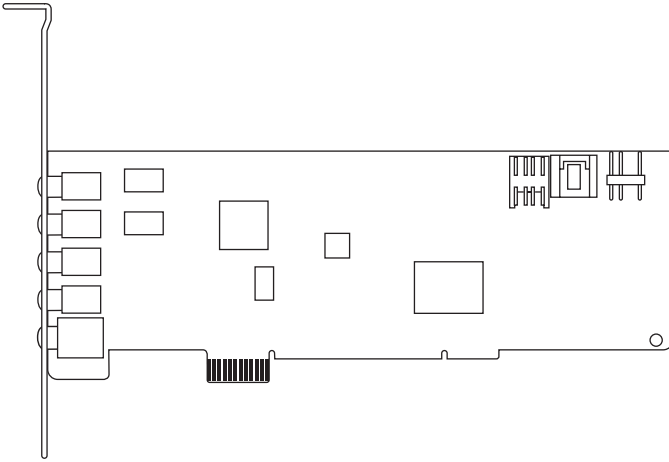

E11099  
Revised Edition (V5)  
November 2015

**Copyright © 2015 ASUSTeK COMPUTER INC. All Rights Reserved.**

No part of this manual, including the products and software described in it, may be reproduced, transmitted, transcribed, stored in a retrieval system, or translated into any language in any form or by any means, except documentation kept by the purchaser for backup purposes, without the express written permission of ASUSTeK COMPUTER INC. ("ASUS").

Product warranty or service will not be extended if: (1) the product is repaired, modified or altered, unless such repair, modification or alteration is authorized in writing by ASUS; or (2) the serial number of the product is defaced or missing.

ASUS PROVIDES THIS MANUAL "AS IS" WITHOUT WARRANTY OF ANY KIND, EITHER EXPRESS OR IMPLIED, INCLUDING BUT NOT LIMITED TO THE IMPLIED WARRANTIES OR CONDITIONS OF MERCHANTABILITY OR FITNESS FOR A PARTICULAR PURPOSE. IN NO EVENT SHALL ASUS, ITS DIRECTORS, OFFICERS, EMPLOYEES OR AGENTS BE LIABLE FOR ANY INDIRECT, SPECIAL, INCIDENTAL, OR CONSEQUENTIAL DAMAGES (INCLUDING DAMAGES FOR LOSS OF PROFITS, LOSS OF BUSINESS, LOSS OF USE OR DATA, INTERRUPTION OF BUSINESS AND THE LIKE), EVEN IF ASUS HAS BEEN ADVISED OF THE POSSIBILITY OF SUCH DAMAGES ARISING FROM ANY DEFECT OR ERROR IN THIS MANUAL OR PRODUCT.

SPECIFICATIONS AND INFORMATION CONTAINED IN THIS MANUAL ARE FURNISHED FOR INFORMATIONAL USE ONLY, AND ARE SUBJECT TO CHANGE AT ANY TIME WITHOUT NOTICE, AND SHOULD NOT BE CONSTRUED AS A COMMITMENT BY ASUS. ASUS ASSUMES NO RESPONSIBILITY OR LIABILITY FOR ANY ERRORS OR INACCURACIES THAT MAY APPEAR IN THIS MANUAL, INCLUDING THE PRODUCTS AND SOFTWARE DESCRIBED IN IT.

Products and corporate names appearing in this manual may or may not be registered trademarks or copyrights of their respective companies, and are used only for identification or explanation and to the owners' benefit, without intent to infringe.

# Contents

Notices.....	iv
Safety information .....	v
Trademarks .....	v
License .....	v
<b>1. Introduction .....</b>	<b>1</b>
1.1 Package contents.....	1
1.2 System requirements .....	1
1.3 Specifications summary .....	2
<b>2. Xonar DSX card layout .....</b>	<b>4</b>
<b>3. Installing the hardware .....</b>	<b>6</b>
3.1 Installing the audio card .....	6
3.2 Connecting to a TV tuner card .....	7
<b>4. Installing software.....</b>	<b>8</b>
<b>5. Connecting speakers and peripherals.....</b>	<b>9</b>
5.1 Connecting digital speaker systems (Home Theater) .....	9
5.2 Connecting stereo headphones .....	10
5.3 Connecting Analog Speaker Systems.....	12
5.4 Connecting a microphone .....	17
5.5 Connecting Line-In audio sources.....	18
<b>6. Xonar Audio Center .....</b>	<b>19</b>
6.1 Xonar Audio Center GUI .....	19
6.2 Main Setting .....	21
6.3 Mixer/Volume .....	27
6.4 Effects .....	30
6.5 Karaoke.....	32
6.6 FlexBass .....	34
6.7 Smart Volume Normalization .....	35
6.8 DS3D GX and DSP Modes .....	37
6.9 VocalFX.....	39
<b>7. Troubleshooting and FAQs.....</b>	<b>42</b>
Troubleshooting .....	42
FAQ .....	44
<b>ASUS Contact information.....</b>	<b>48</b>

# Notices

## Federal Communications Commission Statement

This device complies with Part 15 of the FCC Rules. Operation is subject to the following two conditions:

- This device may not cause harmful interference, and
- This device must accept any interference received including interference that may cause undesired operation.

This equipment has been tested and found to comply with the limits for a Class B digital device, pursuant to Part 15 of the FCC Rules. These limits are designed to provide reasonable protection against harmful interference in a residential installation. This equipment generates, uses and can radiate radio frequency energy and, if not installed and used in accordance with manufacturer's instructions, may cause harmful interference to radio communications. However, there is no guarantee that interference will not occur in a particular installation. If this equipment does cause harmful interference to radio or television reception, which can be determined by turning the equipment off and on, the user is encouraged to try to correct the interference by one or more of the following measures:

- Reorient or relocate the receiving antenna.
- Increase the separation between the equipment and receiver.
- Connect the equipment to an outlet on a circuit different from that to which the receiver is connected.
- Consult the dealer or an experienced radio/TV technician for help.

## Canadian Department of Communications Statement

This digital apparatus does not exceed the Class B limits for radio noise emissions from digital apparatus set out in the Radio Interference Regulations of the Canadian Department of Communications.

This class B digital apparatus complies with Canadian ICES-003.

## Australia statement notice

From 1 January 2012, updated warranties apply to all ASUS products consistent with the Australian Consumer Law. For the latest product warranty details, please visit <http://support.asus.com>. Our goods come with guarantees that cannot be excluded under the Australian Consumer Law. You are entitled to a replacement or refund for a major failure and compensation for any other reasonably foreseeable loss or damage. You are also entitled to have the goods repaired or replaced if the goods fail to be of acceptable quality and the failure does not amount to a major failure.

If you require assistance, please call ASUS Customer Service at 1300 2787 88 or visit us at <http://support.asus.com>.

## Safety information

- Before installing the device on a motherboard, carefully read all the manuals that came with the package.
- To prevent electrical shock hazard or short circuit, switch off the power supply before installing the device on a motherboard or connecting any signal cables to the device.
- If the device is broken, do not try to fix it by yourself. Contact a qualified service technician or your retailer.
- Before using the product, make sure all cables are correctly connected. If you detect any damage, contact your dealer immediately.
- To avoid short circuits, keep paper clips, screws, and staples away from connectors, sockets and circuitry.
- Avoid dust, humidity, and temperature extremes. Do not place the product in any area where it may be exposed to moisture.
- Place the product on a stable surface.
- If you encounter technical problems with the product, contact a qualified service technician or your retailer.



---

This symbol of the crossed out wheeled bin indicates that the product (electrical and electronic equipment) should not be placed in municipal waste. Check local regulations for disposal of electronic products.

---

## Trademarks

Xonar and ASUS logo are trademarks of ASUSTek Computer Inc. “Dolby” and “Dolby Digital Live”, “Dolby Pro Logic IIx”, “Dolby Virtual Speaker”, “Dolby Headphone” are trademarks of Dolby Laboratories. “DTS” and “DTS CONNECT”, “DTS Interactive”, “DTS Neo: PC” are trademarks of Digital Theater Systems, Inc. EAX and A3D are trademarks of Creative Technology Ltd. Microsoft, DirectSound3D, Windows are trademarks of Microsoft Corporation. Other company and product names may be trademarks of the respective companies with which they are associated. ASIO is a trademark and software of Steinberg Media Technologies GmbH.

## License

Dolby Master Studio driver is manufactured under license from Dolby Laboratories; DTS Connect driver is manufactured under license from Digital Theater Systems, Inc.



# **1. Introduction**

## **1.1 Package contents**

- ASUS Xonar DSX PCIE audio card
- S/PDIF TOSLINK optical adapter x1
- Low profile bracket x1
- Support CD
- Quick Start Guide

## **1.2 System requirements**

- One PCIE 1.0 (or higher) compatible slot for the audio card
- Microsoft® Windows® 10 / 8.1 / 8 / Vista / 7 / XP(32/64bit) / MCE2005
- Intel® Pentium® 4 1.4 GHz or AMD® Athlon 1400 CPU or faster CPU
- 256 MB (or above) DRAM system memory
- 60 MB available HDD space for driver installation package
- CD-ROM drive (or DVD-ROM drive ) for software installation
- High-quality headphones, powered analog speakers, or a Dolby Digital or DTS decoder

## 1.3 Specifications summary

Items	Description
<b>Audio Performance</b>	
Output Signal-to-Noise Ratio (A-Weighted):	Up to 107dB
Input Signal-to-Noise Ratio (A-Weighted):	100 dB
Output Total Harmonic Distortion + Noise at 1kHz (A-Weighted):	Up to 0.0017% (-95dB)
Input Total Harmonic Distortion + Noise at 1kHz (A-Weighted):	Up to 0.0017% (-95dB)
Frequency Response (-3dB, 24-bit/96kHz input):	<10Hz to 48KHz
Output/Input Full-Scale Voltage	1 Vrms (5.65 Vp-p)
Sample Rate Conversion Quality	Almost lossless, high-fidelity floating-point filters, with: -140dB THD+N (typical value for 44.1K->48KHz, 24bit) 145dB Dynamic Range (typical value for 44.1K->48KHz, 24bit)
<b>Bus Compatibility</b>	
PCI Express	PCI Express v1.0 or above bus compatible
<b>Main Chipset</b>	
Audio Processor	ASUS AV200 High-Performance Sound Processor (Max. 192KHz/24bit)
D-A Converter of Digital Sources:	Wolfson WM8776*1 (108dB SNR, Max. 192kHz/24bit) Wolfson WM8776*1 (103dB SNR, Max. 192kHz/24bit)
A-D Converter for Analog Inputs:	Wolfson WM8776*1 (102dB SNR, Max. 96kHz/24bit)
<b>Sample Rate and Resolution</b>	
Analog Playback Sample Rate and Resolution	44.1K/48K/96K/192KHz @ 16/24bit for all channels
Analog Recording Sample Rate and Resolution	44.1K/48K/96K @ 16/24bit
S/PDIF Digital Output	44.1K/48K/96K/192KHz @ 16/24bit, Dolby Digital, DTS, WMA-Pro
ASIO 2.0 Driver Support:	44.1K/48K/96K/192KHz @ 16/24bit
<b>I/O Ports</b>	
Analog Output Jack:	3.50mm mini jack*4 (Front/Side/Center-Subwoofer/Back)
Analog Input Jack:	3.50mm mini jack*1 (Line-In/Mic-In)
Other line-level analog input (for CD-IN/TV Tuner):	Aux-In (4-pin header on the card)

(continued on the next page)



Items	Description
Digital S/PDIF Output	High-bandwidth Optical Connector supports 192KHz/24bit (shared with Back surround output jack) - additional S/PDIF out header for HDMI audio output
Front-Panel Audio Header	Intel HDA front-panel compatible and supports HP jack-detection and automatically switch audio output from back-panel to front
<b>Driver Features</b>	
Operating System	Windows® 10 / 8.1 / 8 / Vista / 7 / XP(32/64bit) / MCE2005
DTS® Technologies	DTS Connect (DTS Interactive Encoder and DTS Neo:PC) for both Windows® XP and Windows® Vista - DTS Interactive encodes any 3D gaming audio into true-to-life 5.1 DTS Digital surround sound experience - DTS Neo:PC could expand any stereo music to 7.1 surround sounds
DirectSound3D Game Extensions 2.5 (DS3D GX 2.5)/DirectX	DS3D GX 2.5.0 supports EAX gaming sound effects and DirectSound 3D hardware enhanced functions on Windows® Vista. (DirectX/DirectSound 3D compatible)
Smart Volume Normalizer™	Normalizes the volume of all audio sources into a constant level and also enhances your 3D sound listening range and advantages in gaming
VocalFX™	The latest vocal effect technologies for gaming and VoIP: -VoiceEX: produces vivid environmental reverberation for EAX games -ChatEX: emulates different background environment effects when you chat online -Magic Voice: changes your voice pitch to different types (Monster/Cartoon...) for disguising your real voice or just for fun when chatting online
Karaoke Functions	Music Pitch-Shifting, Voice Cancellation, and Microphone Echo effects with Stereo Mix recording (Wave and Mic-In) for online Karaoke or DJ applications
FlexBass™	Professional Bass Management/Enhancement system
Xear 3D™ Virtual Speaker Shifter	Adjustable virtual 7.1-speaker positioning
Other Effects	10-band Equalizer/27 Environment Effects
3D Gaming Sound Engines/APIs	Windows Vista: DirectSound3D® GX 2.5, EAX® 2.0&1.0, DirectSound® HW, DirectSound® SW, A3D® 10, OpenAL generic modes, 128 3D sounds processing capability
<b>Bundled Software</b>	
RMAA 6.0.6	RightMark Audio Analyzer utility to easily test the audio quality of the sound card in your PC.
<b>Accessories</b>	
Accessories	- Low profile bracket - S/PDIF TOSLINK optical adapter

\*Specifications are subject to change without notice.

## 2. Xonar DSX card layout

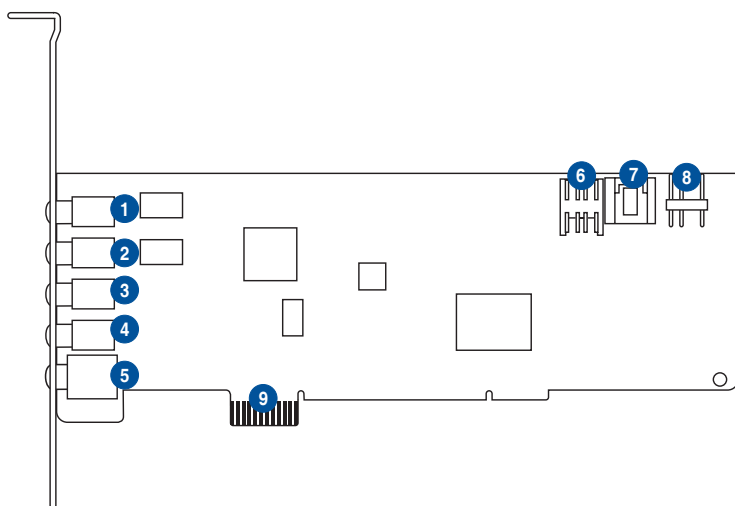

### Audio ports

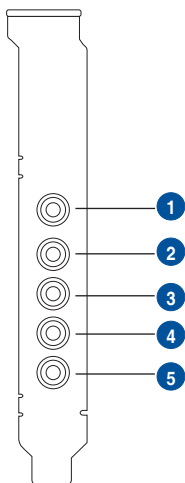

No	Item	Description
1	Microphone In port	Connect your external PC microphone to this 3.5mm port for voice input. Built-in high-quality Microphone pre-amplifier.
1	Line In port	Connect analog devices like MP3 players, CD players, music synthesizers and other line-level sound sources to this 3.5mm port for audio recording or processing (through an ultra-high fidelity 102dB SNR A-D converter).
2	Headphone/Front Out port	Connect your headphones or 2/2.1 channel speakers to this 3.5mm port. For multi-channel speaker systems, this port connects to the front left/right input on the powered speakers.
3	Side Surround Out port	Connects to the surround channel input on 4/4.1/5.1/6.1/7.1 powered analog speakers.
4	Center/Subwoofer Out port	Connects to the center/subwoofer input on 5.1/6.1/7.1 powered analog speakers.
5	Rear/back Surround Out port	Connects to the Back Surround input on 6.1/7.1 powered analog speakers.
5	S/PDIF Out port	Optical TOSLINK digital output port. Connects to external digital decoder or digital speaker systems, Home Theater systems, AV receivers for outputting digital audio including PCM, DTS Digital, DTS, WMA-Pro, etc.
6	Front panel audio header	Intel HDA front-panel compatible and supports HP jack-detection and automatically switches audio output from the back panel to the front panel.  Supports both front-panel and sound card mic input mixing
7	Aux Input Header	Connects to the Analog Audio output of a TV tuner card or other sound source inside your PC system. (To monitor your TV tuner card's audio from this Aux-In, you must enable the "monitor" function for Aux-In in the Xonar DSX Audio Center's recording mixer.)
8	S/PDIF Out header	Connects to the graphics card with HDMI support.
9	PCI Express Bus Golden Fingers	Insert into the PCI Express slot on your motherboard.

## 3. Installing the hardware

### 3.1 Installing the audio card



---

Before you proceed with the following installation steps, it's recommended that you disable your onboard audio device in your BIOS settings, or uninstall any other audio cards on your PC. (For BIOS setting or uninstallation of other sound cards, refer to the user manuals of your motherboard and audio card.)

---

#### Installing the Xonar DSX card

1. Power OFF the computer, the monitor, and all other peripheral devices connected to your computer.
2. Unplug the computer power cord from your computer and power outlet.
3. Touch the metal back or side panel of the computer to avoid static electricity.
4. Remove the chassis cover.
5. Remove the metal bracket from an available PCIE slot for the Xonar DSX audio card.
6. Carefully insert the audio card into the PCIE slot. Ensure the audio card sits properly in place.
7. Secure the audio card with screws and the metal bracket.
8. Put back the chassis cover.
9. Reconnect all cables.
10. Plug the power cord to the computer and to a power outlet.
11. Power ON the computer.

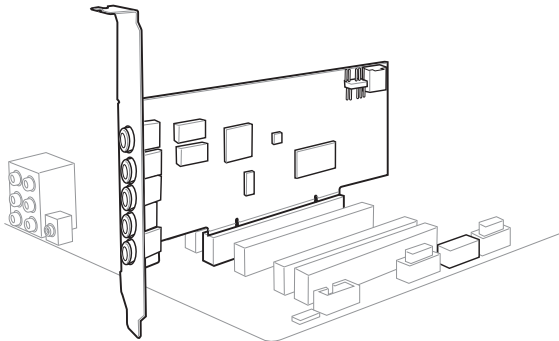

## 3.2 Connecting to a TV tuner card

1. If you have a traditional PCIE or PCIE TV tuner card on your PC, you may need to connect it to the Xonar DSX card to send the tuner card's sound to your PC speakers.
2. Secure the PCIE/PCIE TV tuner card and screw it into the back-panel.
3. Connect the audio output header from the TV tuner card to the Aux-In header of the Xonar DSX card.



---

For optimum TV audio quality, Xonar DSX uses ADC recording to digitize the signal and loop it back for DAC playback. Select Aux-In as the recording source in the Xonar DSX Center's recording mixer and enable the monitoring button to pass this signal to the audio output. Using this setup, you can even turn on sound effects such as Pro-Logic IIx to expand the stereo TV audio to 5.1 or 7.1 channel surround sound. TV audio on your PC will become even better than on your TV set.

---

## 4. Installing software

### Installing the card driver



---

Ensure that you have installed the audio card driver before installing the Xonar DSX driver. Otherwise, driver installation error may occur.

---

1. After you have installed the Xonar DSX card, turn on your computer. Windows® automatically detects the audio card and searches for device drivers. When prompted for the drivers, click **Cancel**.
2. Insert the support CD into the optical drive. If Autorun is enabled on your system, the setup starts automatically. If not, run **setup.exe** from your support CD.
3. Follow the onscreen instructions to finish the installation.



---

The version and content of the support CD are subject to change without notice.

---

## 5. Connecting speakers and peripherals

### 5.1 Connecting digital speaker systems (Home Theater)

The Xonar DSX supports DTS Interactive technology, which transcodes any audio, including games and music, into industry-standard DTS surround bit-streams. This makes playback through your home theater system possible, creating an immersive and impressive cinema surround sound experience. A single digital cable connection can carry high-quality DTS digital audio from any of your PC audio sources to any digital speakers or AV Receivers with DTS 5.1 decoding capabilities.

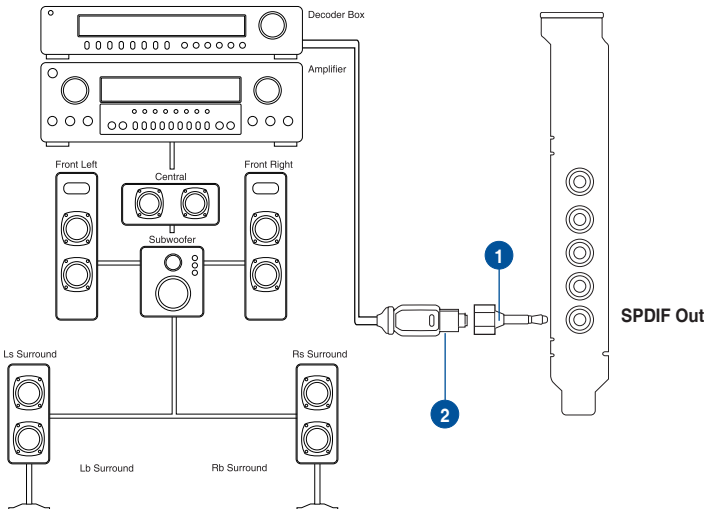

No	Item	Description
1	Optical adapter	Plug the optical TOSLINK adapter into the S/PDIF-Out combo connector.
2	Optical cable	Connect your decoder's S/PDIF-In port to the optical adapter with the TOSLINK optical cable.

## 5.2 Connecting stereo headphones

### 5.2.1 Connecting Stereo Headphones

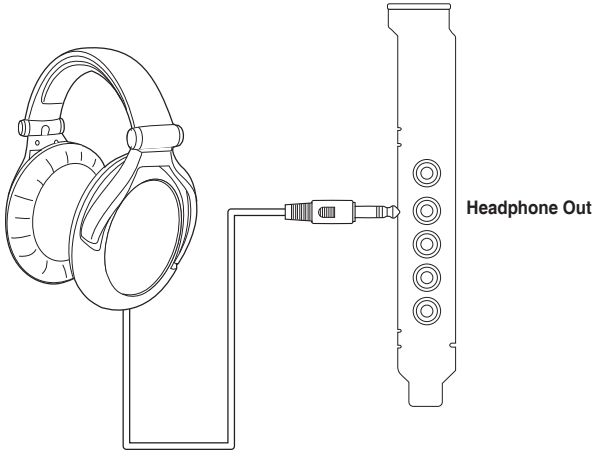

No	Item	Description
1	Front Out/Headphone Jack	The Front Out jack has a built-in high-quality amplifier to drive headphones. Connect your stereo headphones directly to this jack.



## 5.2.2 Connecting 5.1 channel Headphones

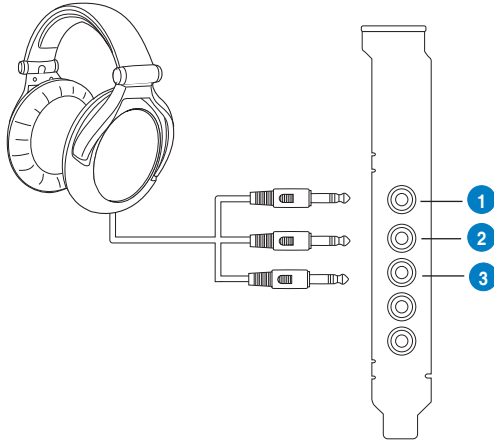

No	Item	Description
1	Front Out	Connect the front-channel 3.5mm plug of your 5.1 headphones into this jack.
2	Side Surround Out	Connect the surround-channel 3.5mm plug of your 5.1 headphone into this jack.
3	Center/Subwoofer Out	Connect the Center/Bass-channel 3.5mm plug of your 5.1 headphone into this jack.

## 5.3 Connecting Analog Speaker Systems

### 5.3.1 Connecting Analog Power Amplifier

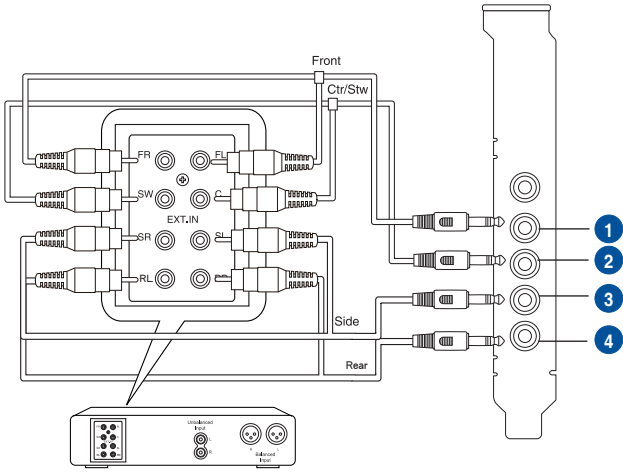

No	Item	Description
1	Front Out	Connects to the "left front" and "right front" input ports of the analog amplifier with the mini-jack to RCA cable.
2	Side Surround Out	Connects to the "left surround" and "right surround" input ports of the analog amplifier with the mini-jack to RCA cable.
3	Center/Subwoofer	Connects to the "Center" and "subwoofer" input ports of the analog amplifier with the mini-jack to RCA cable.
4	Back Surround Out	Connects to the "left back" and "right back" input ports of the analog amplifier with the mini-jack to RCA cable.

## 5.3.2 Connecting 2/2.1 channel speakers

### 2 Speakers

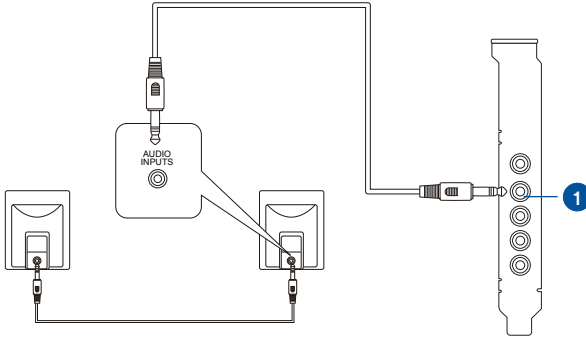

### 2.1 Speakers

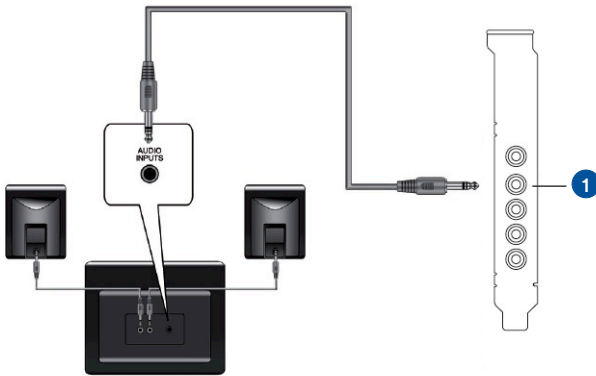

No	Item	Description
1	Front Out/Headphone Jack	Connect the 2/2.1 speaker set's 3.5mm plug into this Front Out jack.

### 5.3.3 Connecting 4/4.1 Channel Speakers

#### 4 Speakers

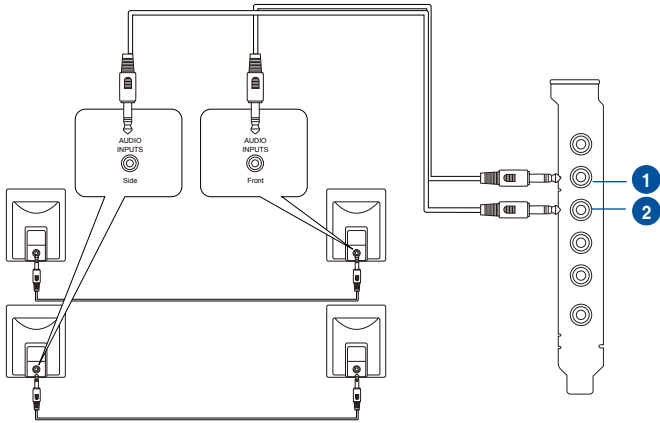

#### 4.1 Speakers

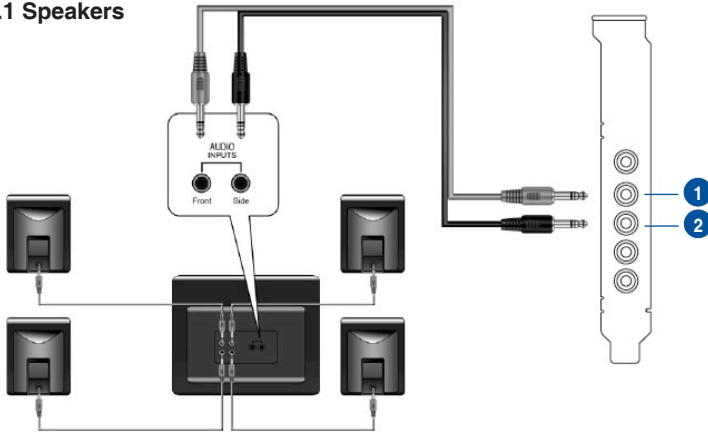

No	Item	Description
1	Front Out	Connects to the Front input port of the 4/4.1 speakers with the mini-jack cable.
2	Side Surround Out	Connects to the Surround input port of the 4/4.1 speakers with the mini-jack cable.

## 5.3.4 Connecting 5.1 Channel Speakers

### 5.1 Speakers

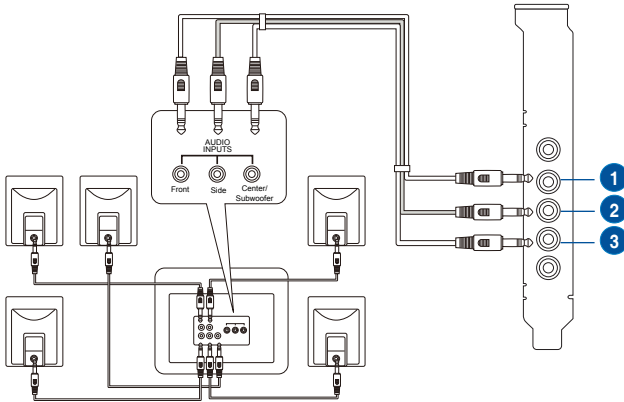

No	Item	Description
1	Front Out	Connects to the Front input port of the 5.1 speakers with the mini-jack cable.
2	Side Surround Out	Connects to the Surround input port of the 5.1 speakers with the mini-jack cable.
3	Center/Subwoofer	Connects to the Center/Subwoofer input port of the 5.1 speakers with the mini-jack cable..

## 5.3.5 Connecting 6.1/7.1 Channel Speakers

### 6.1 Speakers

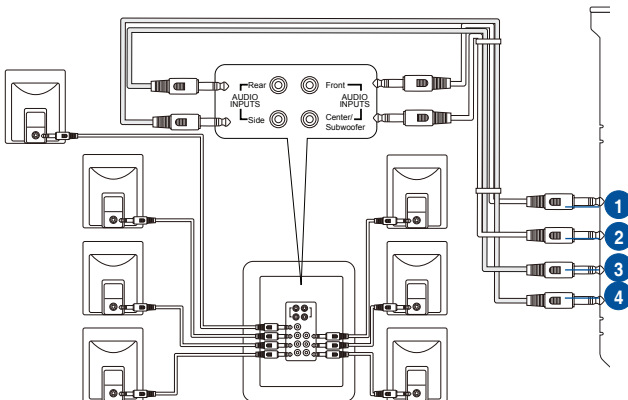

## 7.1 Speakers

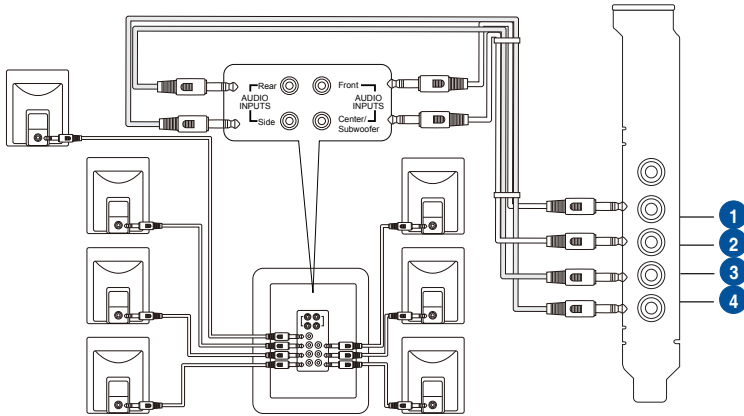

No	Item	Description
1	Front Out	Connects to the Front input port of the 6.1/7.1 speakers with the mini-jack cable.
2	Side Surround Out	Connects to the Surround input port of the 6.1/7.1 speakers with the mini-jack cable.
3	Center/Subwoofer	Connects to the Center/Subwoofer input port of the 6.1/7.1 speakers with the mini-jack cable.
4	Back Surround Out	Connects to the Back Surround input port of the 6.1/7.1 speakers with the mini-jack cable.

## 5.4 Connecting a microphone

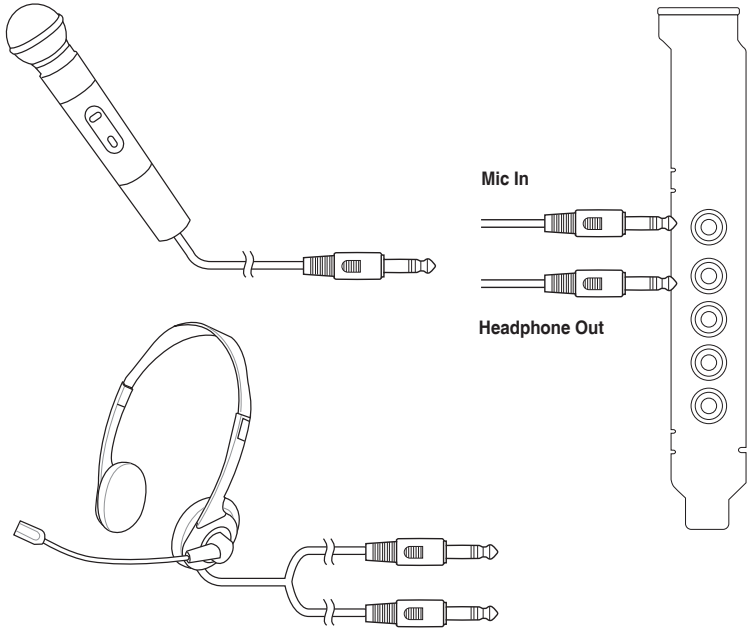

No	Item	Description
1	Microphone Input Jack	Connect the microphone's 3.5mm plug into this Mic-In jack for voice communication, recording, or karaoke.
2	Headphone Jack	The Front Out jack has a built-in high-quality amplifier to drive headphones. Connect your stereo headphones directly to this jack.

## 5.5 Connecting Line-In audio sources

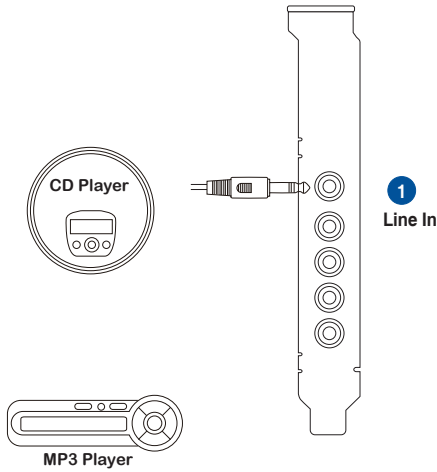

No	Item	Description
1	Line Input Jack	Connect the 3.5mm plug of the CD/MP3 Player or any other Line level analog audio sources into this Line-In jack for sound recording or real-time Dolby sound processing through the Monitoring path (See the "Mixer" section of the driver guide).



## 6. Xonar Audio Center

### 6.1 Xonar Audio Center GUI

1. After the driver installation is complete and your computer has been rebooted, you will find the Xonar Audio Center's icon in the system tray on the bottom right-hand corner of the screen. Double click this icon to open the Xonar Audio Center utility.



If the icon could not be found in the system tray, launch the Xonar Audio Center from the Windows® desktop by clicking **Start > All Programs > ASUS Xonar DSX Audio > Xonar DSX Audio Center**.

2. The Xonar Audio Center is the Graphical User Interface (GUI) for the Xonar DSX driver. You can control the functions and features of the Xonar DSX driver on the Xonar Audio Center. The following picture shows a basic overview of the Xonar Audio Center. The following sections of this manual will describe its functions in more detail.



No	Item	Description
1	Support link	Clicking this button will open the ASUS official website.
2	Display Area	This display area shows the 10-band signal meter, volume level, and the status of the Dolby/DTS technologies, EQ, and DSP modes.  *This area displays information, but is not used to change settings.
3	Setting Menu Panel	This panel gives access to the setting tabs, including Main Settings, Mixer/volume, Effects, Karaoke, FlexBass, and VocalFX.
4	Information icon	Clicking this icon will display the driver information window.
5	Menu Open/Close	Clicking this button will reveal the configuration settings. Clicking it again will move the display area back to its original position and hide the configuration area.
6	Master Volume	This knob controls the master playback volume. Turn to change the volume level.
7	Mute Button	Click this button to mute audio playback. It will display a red light when playback is muted.
8	SVN Button	Click this button to enable the "Smart Volume Normalization" feature for constant volume from all playback sources. It will display a blue light when enabled.
9	DSP Mode	These 2 buttons give access to quick gaming surround sound effect (GX2.5) and effect-free (Hi-Fi) modes.

## 6.2 Main Setting

### 6.2.1 Sample Rate

The sample rate determines the number of audio samples per second that the Digital-to-Analog Converters (DAC) and S/PDIF digital interface will output. The Xonar DSX card can support sample rates up to 192KHz (44.1K, 48K, 96K, 192KHz). Audio CDs and MP3 files are typically at 44.1KHz; DVD-Video uses 48KHz; DVD-Audio or other HD media may contain 96KHz or 192KHz high-definition audio content. Select the corresponding sample rate for your playback sources to get the best audio quality. Even if your setting differs from the audio source's sample rate, the Xonar DSX engine will execute super high-fidelity sample-rate-conversion with a double floating-point filter, which can reduce total harmonic distortion (THD+N) by -140dB.

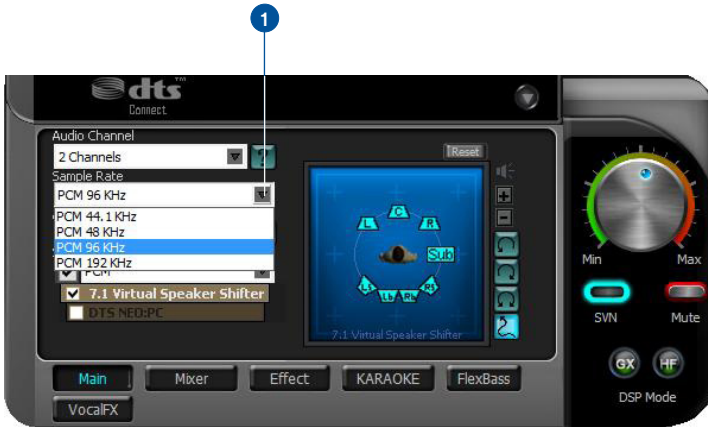

No	Item	Description
1	Sample Rate	Select the sample rate that corresponds to (or exceeds that of) your playback sources, for optimal audio fidelity. The Xonar DSX card supports sample rates up to 192KHz (44.1K, 48K, 96K, 192KHz). Typical values for sample rates are: <ul style="list-style-type: none"><li>- Audio CD, MP3, WMA, Wave files are 44.1 KHz</li><li>- DVD-video audio is 48KHz</li><li>- DVD-Audio or other HD media may contain 96KHz or 192KHz high-definition audio content</li></ul>

## 6.2.2 Analog Out mode

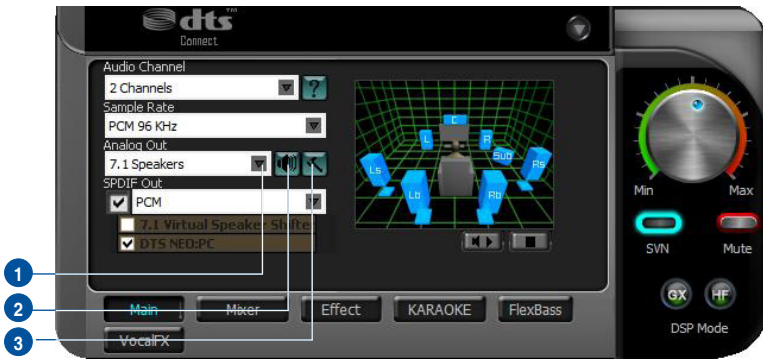

No	Item	Description
1	Analog Out	The Analog Out setting is used to adjust audio to your actual speaker setting, such as headphones, 2 speakers (or 2.1), 4 speakers (or 4.1), 5.1 speakers, 7.1 speakers, Front Panel Headphone and Front Panel 2 speakers (or 2.1). Xonar DSX will play the channels and process the proper 3D/DTS sound accordingly. Select the correct speaker type for your connected speakers.
2	Speaker Test	Click this button to show the speaker test window in the right pane. Click the "play" button to test each speaker one by one or click each speaker to test them individually.
3	HP Advanced Setting	Clicking this button will display an advanced setting window to <ul style="list-style-type: none"> <li>Swap center/bass output for 5.1/7.1-speaker set up</li> <li>Swap Side/Back Surround output for 7.1-speaker set up</li> </ul> Select the appropriate Speaker Swap options if your speakers are outputting the incorrect channel. Otherwise, leave them blank. <div data-bbox="391 1114 595 1225" style="border: 1px solid gray; padding: 5px; margin-top: 10px;"> <p>Speaker Swap</p> <p><input type="checkbox"/> Swap center/bass output</p> <p><input type="checkbox"/> Swap side/back surround output</p> <p style="text-align: center;">OK</p> </div>

### 6.2.3 SPDIF Out / DTS Interactive

Xonar DSX is capable of producing DTS Interactive audio, which is audio transcoded real-time into industry-standard DTS Digital bit-streams on-the-fly. This is ideal for playback through a home theater system, creating an immersive and impressive cinema surround sound experience. This technology enables a single digital connection to carry high quality DTS surround audio from your PC to digital speakers and AV Receivers.

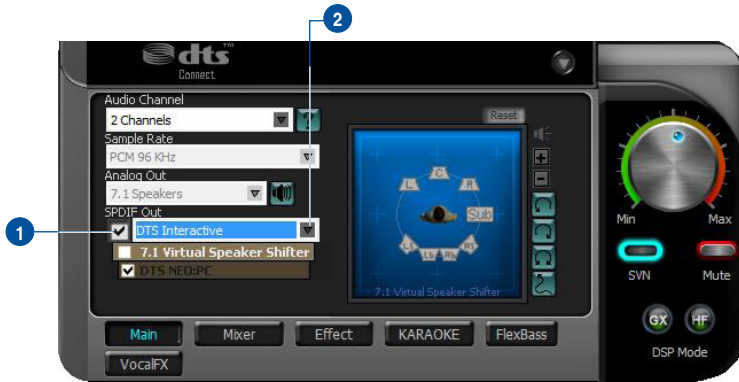

No	Item	Description
1	S/PDIF Out enable/disable	Click this check box to enable S/PDIF output.
2	S/PDIF Output Formats/Functions	This pull-down menu allows you to select one of the following formats: <ul style="list-style-type: none"> <li>• PCM (Pulse Code Modulation) - a common raw audio data format</li> <li>• DTS Interactive, real-time 5.1-channel encoding</li> </ul>

## 6.2.4 Audio Channels (For Windows® Vista only)

This setting only appears in Windows® Vista. Vista will deliver the audio channels to the audio driver according to this setting no matter what the original audio content is or how many channels they have. Configure your audio channel based on your audio content before playback. Please note that this setting is synchronized with Vista's system speaker configuration and changing the setting during playback will stop audio playback. You may have to restart the program after making changes. It's recommended that you close all multimedia programs before you change this setting.

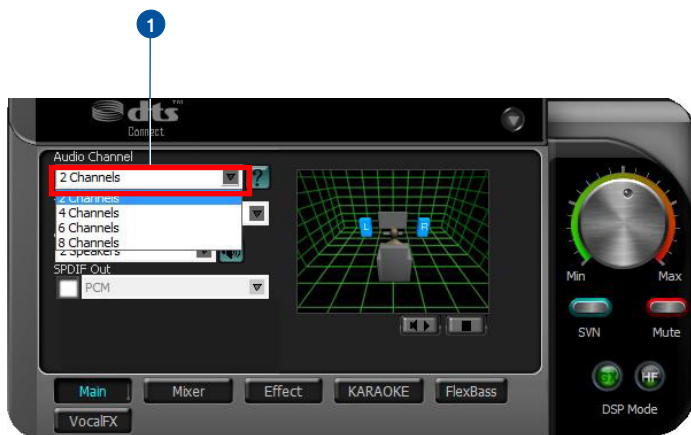

No	Item	Description
1	Audio Channels	Recommended settings: <ul style="list-style-type: none"><li>- MP3, WMA, AAC, CD, VCD, 2D games =&gt; 2 channels</li><li>- DVD-Video with Dolby Digital or DTS 5.1 =&gt; 6 channels</li><li>- DVD-Video with Dolby Digital EX or DTS ES =&gt; 8 channels</li><li>- 3D games =&gt; 8 channels</li></ul>

## 6.2.5 7.1 Virtual Speaker Shifter

The 7.1 Virtual Speaker Shifter has the following major features:

- Expanding/upmixing audio to 7.1-channel surround sound
- Virtualizing 7.1 surround sound over any set of speakers
- Virtual speakers that can be positioned to improve sound quality without having to move physical speakers and wires

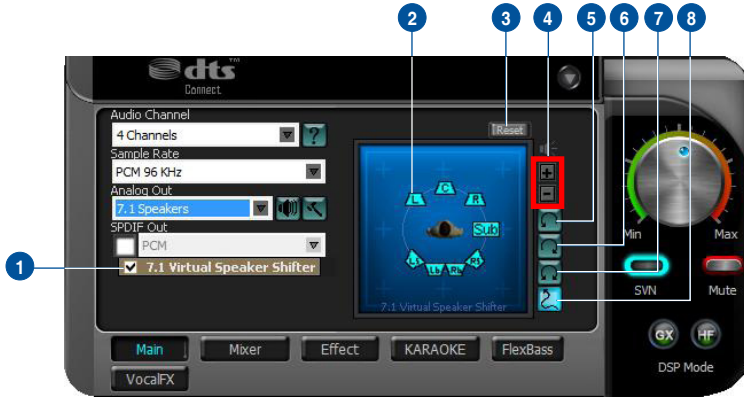

No	Item	Description
1	Shifter enable/disable	Click this check box to enable the 7.1 Virtual Speaker Shifter. Clicking the text bar will switch the right window to the Speaker Shifter page for manual adjustments.  *Settings will be retained even when a different Analog Output is selected.
2	Drag speaker or listener	You can drag each speaker or listener to a different position "virtually" using only your mouse. The Xonar DSX card will process the sound and reposition the virtual speakers real-time. The Subwoofer does not emit directional sounds, and hence can be moved only closer to or further away from the listener.
3	Reset	Resets all Speaker Shifter settings to defaults.
4	Increase/decrease volume	Click + to increase volume (moves speakers closer); click - to decrease volume (moves speakers further away)
5	Counter-clockwise	Make all speakers (except Subwoofer) rotate counter-clockwise
6	Clockwise	Make all speakers (except Subwoofer) rotate clockwise
7	Manual Rotation	Manually drag and rotate all speakers (except Subwoofer)
8	Manual Drag Mode	The default mode allows you to manually drag each speaker or the listener with your mouse.

### 6.2.6 DTS Neo:PC

DTS Neo:PC is a 7.1 surround upmixing technology and is widely used in home theater systems, TVs, game consoles, and car audio systems. It can expand stereo audio from MP3s, CDs, and TV programs into immersive 5.1 or 7.1-channel surround.

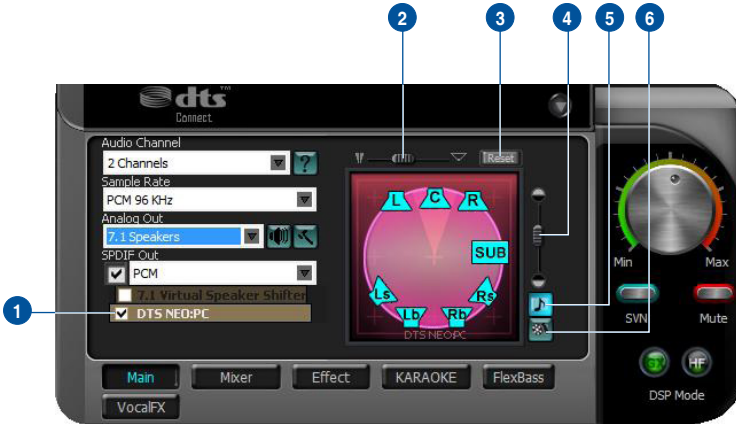

No	Item	Description
1	DTS Neo:PC enable/disable	Click this check box to enable DTS Neo:PC. Clicking the text bar will switch the right window to the Pro-Logic IIx page for manual adjustments.
2	Center Width	This setting is used to adjust how audio expands from the center speaker and is used for audio vocals in songs and music. Drag the scroll bar to the left to centralize the vocal signal. Drag the scroll bar to the right to widen the vocal sound range.
3	Reset	Reset all settings to defaults.
4	Dimension	The dimension setting adjusts how audio fades from the front or rear of the listener.
5	Music Mode	Music mode is the default mode for regular music playback. In this mode, you can adjust the Center Width and Dimension parameters.
6	Movie Mode	Movie mode is a preset optimized for movie audio.



## 6.3 Mixer/Volume

The mixer page is designed to control the volume for playback and recording on the Xonar DSX. In addition, the Xonar DSX also provides a high-quality digital monitoring function for hearing the recorded audio from the speakers. You can also process the input signals with all playback sound effects including DTS technology.

### 6.3.1 Playback Volume

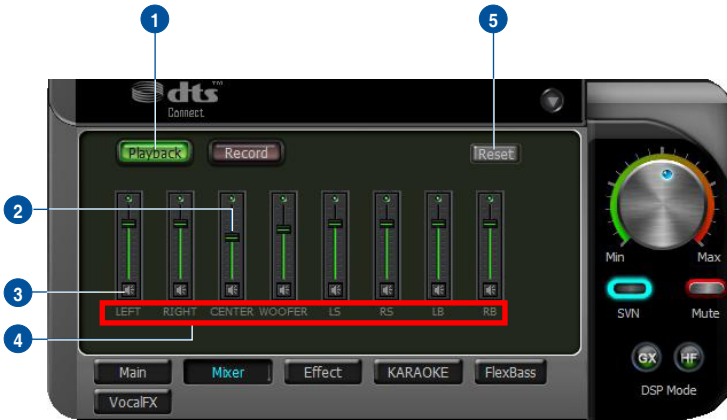

No	Item	Description
1	Playback volume tab	Click this button to show the playback volume page.
2	Volume slider	Drag this slider down to decrease the volume; drag it up to increase the volume. The tool-tip displays percentage increments.
3	Mute button	Click this button to mute the audio channel; click this button again to restore the audio output.
4	Source / path name	Displays the source name for each volume control slider*: <ul style="list-style-type: none"> <li>- WAVE: All digital audio sources except MIDI files</li> <li>- SW: Software Synthesizer; control the playback volume of the MIDI files</li> <li>- CD: CD-ROM digital playback (CD-DA) volume control</li> <li>- LEFT, RIGHT, CENTER, WOOFER: volume control for each speaker/ channel</li> </ul> <p>*Windows® Vista does not support WAVE, Synthesizer, and CD-In volume controls.</p>
5	Reset	Reset all volume controls to the default settings

### 6.3.2 Recording/Monitoring Volume

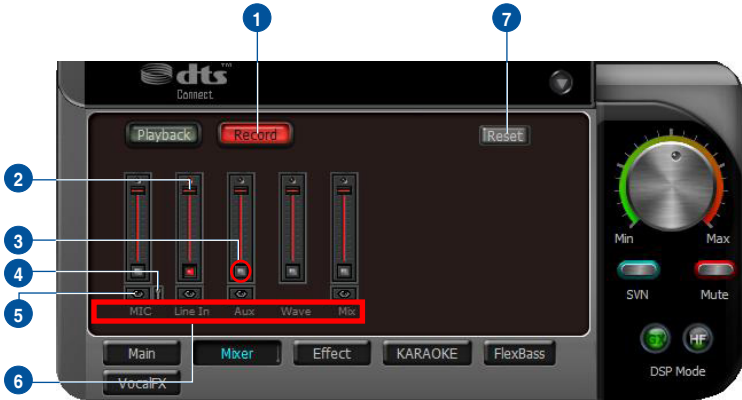

No	Item	Description
1	Recording Volume Tab	Click this button to show the recording volume page.
2	Recording volume slider	Drag this slider down to decrease the recording volume; drag up to increase the recording volume. The tool-tip displays percentage increments.
3	Recording Selector button	Click this button to select the path/source you are going to record. Note that the recording function on Windows® is a one-path selector. You can select only one default recording source at a time. You may have to restart the recorder program if you switch to a different source.  *On Windows® Vista, some applications allow you to select the recording device/path in the application itself.
4	Microphone-In Advanced Setting	Click the  button to open the advanced settings for the Microphone-In:  <div data-bbox="388 1005 595 1125" data-label="Image"> </div> Enabling "Microphone Boost" will increase volume gain to boost microphone input signals. If you connect your microphone to the front panel audio module, enable "Front Panel Microphone". This setting is recommended for low-cost PC microphones.
5	Monitoring button	Click this button to monitor and loopback recording audio to output speakers. The recording volume will affect the monitoring signals from speaker output. The audio will be mixed into the streams from your PC and all DSP effects will be applied to both the source and the output. A typical application is to apply DTS Neo:PC 7.1-ch spreading to your TV audio, CD, MP3, or stereo game console audio from a gaming device such as Wii, XBOX, PS2/PS3/PSP, etc.

(continued on the next page)

6	Source / path name	<p>Displays the source name for each volume control slider:</p> <p><b>S/PDIF-In:</b> S/PDIF digital input source</p> <p><b>MIC:</b> recording from MIC jack</p> <p><b>Mix:</b> Stereo Mix will record MIC + Front Panel MIC + WAVE audio</p> <p><b>Aux:</b> recording from Aux-In sources such as TV-tuner audio cards or other sound sources</p> <p><b>Line-In:</b> recording from Line-in jack for external audio devices</p> <p><b>WAVE:</b> recording from digital wave audio you are playing on your PC</p>
7	Reset	Click to reset all volume controls to the default settings.

## 6.4 Effects

### 6.4.1 Environment Effects

Environment effects can be used to create realistic listening experiences that mimic different environments. There are a total of 27 environment options, which can be applied to music and other 2D sound sources.

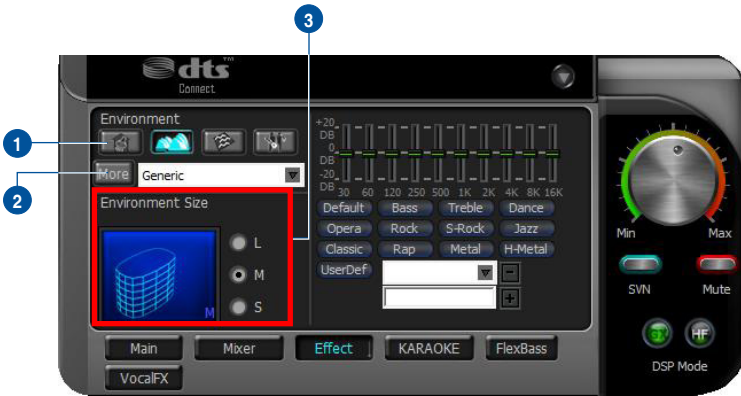

No	Item	Description
1	Default environments	These four buttons activate Bathroom, Concert hall, Underwater, and Music Pub environments, respectively.
2	More options	Clicking this button will apply the environment effect selected from the pull-down menu. 23 additional options are available in this menu.
3	Environment size	There are three size settings for each environment: Large, Medium, and Small.

## 6.4.2 10-Band Equalizer

The equalizer can modify the audio output for different frequencies and can be used to compensate for deficiencies in your speakers/sound system. You can create custom settings in addition to the 12 default patterns available.

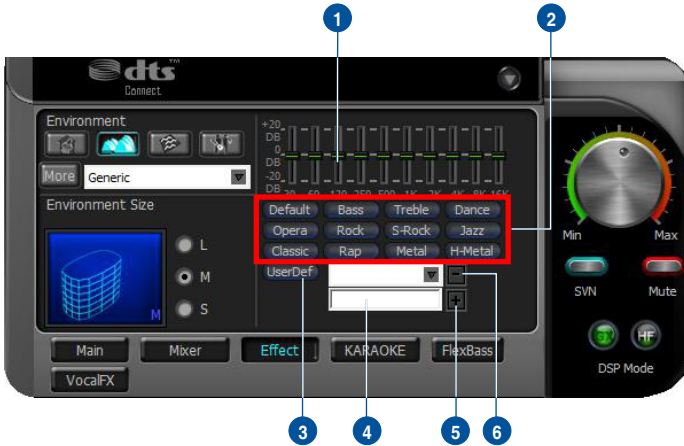

No	Item	Description
1	Default equalizer options	There are 12 available equalizer patterns. Click an item to apply a pattern to audio playback.
2	Equalizer slider	Adjust the gain for each band (30~16KHz)
3	User Defined	You can click this button to apply a selected User Defined setting.
4	Save name	Type a name for your own "User Defined" equalizer setting in the text box.
5	Add / save	Click the "+" button to add the defined parameters to the User Defined list as a preset.
6	Delete	Click the "-" button to delete a saved preset from the User Defined list.

## 6.5 Karaoke

The Xonar DSX provides powerful features for Karaoke, including Key-Shifting, Vocal Cancellation, and Microphone Echo. Microphone Echo can generate natural echo effects on your singing voice just like a karaoke machine. Key-Shifting can change the pitch of Karaoke background music, and Vocal Cancellation can reduce the original vocal in songs and keep the music and symphony for karaoke.

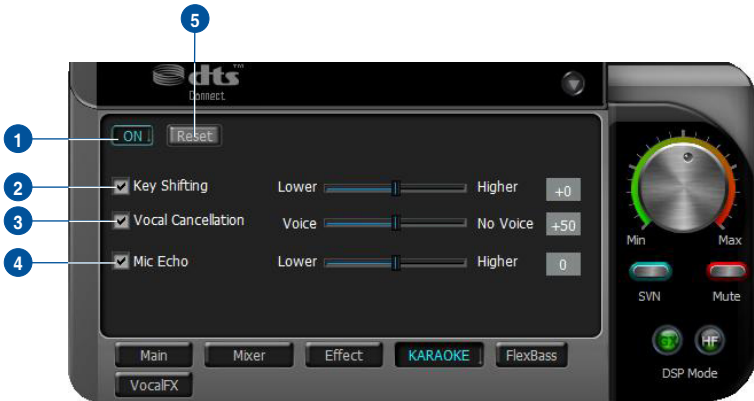

No	Item	Description
1	On/Off	Click the switch to turn on or off the functions on this page.
2	Key-Shifting	Select the box to enable or disable the key shifting feature for music playback from 4 semitones below to 4 semitones above.
3	Vocal Cancellation	Select the box to enable or disable the vocal cancellation function and adjust the voice cancellation level from 0 to +100. +100 will eliminate most original vocals (default value is 50).
4	Mic Echo	Select the Mic Echo function and adjust the gain for echo signals (30-16KHz)
5	Reset	Reset all settings to defaults.



---

The following message appears when Mic Echo is selected:



Select a recording source from the list. With Mic, you will only record audio source from microphone with echo effects; but you are able to record all audio sources from Wave, Aux, and Mic with microphone echo effect. Click **OK** to accept or **Cancel** if you want to enable the setting later. Select **Don't remind me again** to prevent the message from being displayed again.

---

## 6.6 FlexBass

FlexBass is an advanced bass management and enhancement mechanism that allows you to select each satellite speaker's type for optimal sound performance. It comes with an adjustable crossover frequency for the boundary of the bass signals. FlexBass will filter out the bass signals from small speaker channels and redirect them to the subwoofer or large speakers.

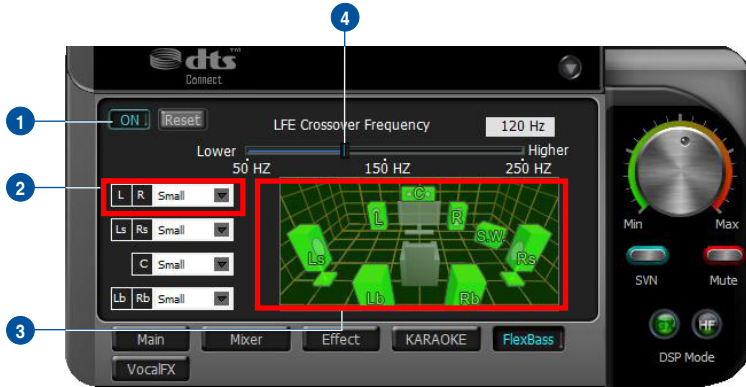

No	Item	Description
1	On/Off	Click this button to disable or enable all FlexBass functions.
2	Small / Large speaker option	<p>Select the speaker type connected to the Xonar D-Kara. If your speaker type cannot handle low-frequency signals (bass), select "Small" speaker type. Xonar D-Kara will filter out the bass signals and send them to the subwoofer channel. If the speakers support full-range signals, you can select the "Large" speaker type.*</p> <p>*In most cases, low-cost desktop PC 2-channel speakers are small-type speakers. Refer to speaker's specifications or consult your speaker vendor to identify correct speaker type. However, common 2.1 speakers with a subwoofer should be categorized as large speakers because the subwoofer can redirect the bass signals inside the two channels to the subwoofer speaker automatically.</p>
3	Picture for Small/ Large speaker	<p>Small/large speakers are identified by their colors:</p> <p>Orange: large speakers</p> <p>Green: small speakers</p>
4	LFE Crossover Frequency	Adjusts the cut-off frequency (50-250Hz) for LFE (Low-Frequency Effects) signals. Xonar D-Kara will filter out bass signals below the crossover frequency from small speaker channels and forward them to the subwoofer. Higher crossover frequency values would result in reduced bass signals.



### 6.7 Smart Volume Normalization

Smart Volume Normalization™ (SVN) automatically keeps all music or video/TV audio output at a constant level to reduce manual adjustment inherent with sound sources of different loudness. It allows you to listen to various content, like MP3, TV program, DVD video and even games at a consistent sound level. The following graph shows how signals 1 and 2 adjust to the same level (for example, 10dB below full scale) after you turn on SVN. In the illustration below, lower volume music 2 becomes louder when you turn on SVN while higher volume music 1 becomes quieter with SVN enabled.

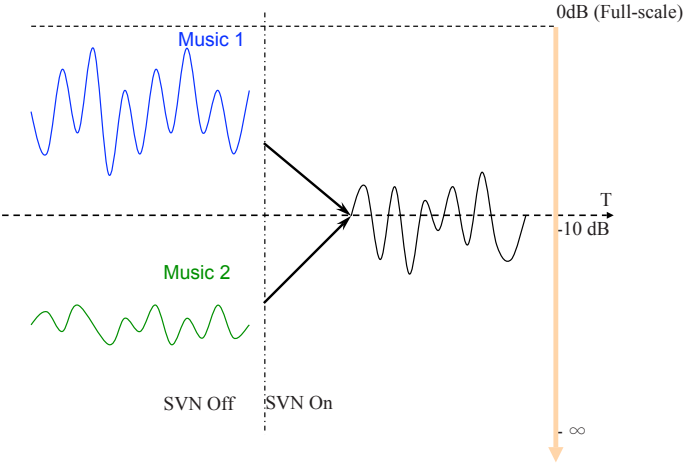

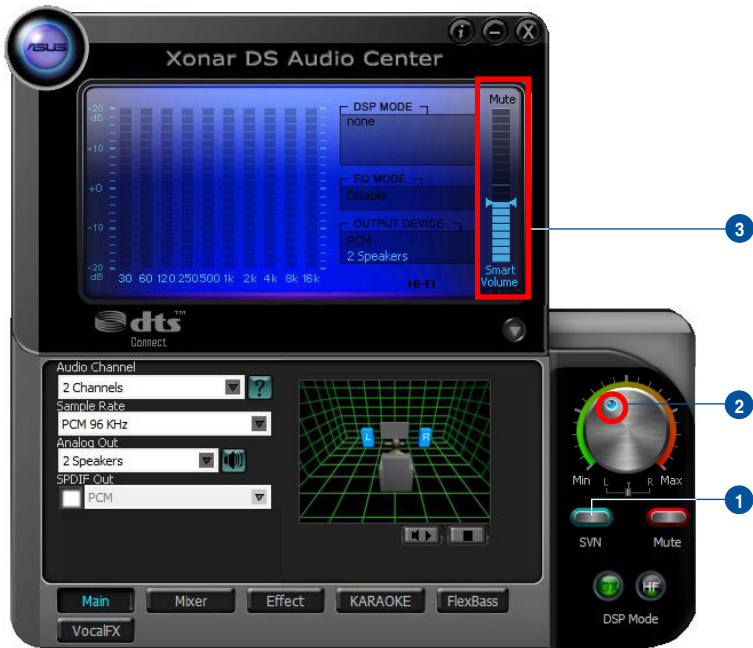

No	Item	Description
1	SVN On/Off	Click this button to enable SVN. This button is outlined blue when active.
2	SVN blue light	When SVN is enabled, the master volume knob will be illuminated by a blue light. The knob will be color red if the volume is muted.
3	SVN display	When SVN is enabled, the "Smart Volume" meter will light up and indicate the volume level.

## 6.8 DS3D GX and DSP Modes

Xonar DSX introduces an innovative technology – DirectSound 3D Game Extensions v2.5 (DS3D GX 2.5) - to restore DirectSound 3D Hardware acceleration mode and its subsidiary EAX effects on Windows® Vista for 3D games. Unlike some proprietary API like OpenAL, DS3D GX doesn't require games to support OpenAL API. All existing games compatible with Microsoft DirectX and DirectSound 2D/3D will be supported with DS3D GX technology. Before you start EAX and DS3D HW games, enable DS3D GX on the Xonar Audio Center, and disable the function after playing.

In addition, Xonar DSX also offers a Hi-Fi mode for hi-fidelity playback without any effect processing to retain original audio fidelity. Every time you turn on Hi-Fi mode, Xonar DSX will clear all sound effects. It's also recommended to use Hi-Fi mode for audio quality tests (using RMAA software or another machine-based measurement). Use the DSP mode button to quickly enable this feature without having to configure all the settings.



---

No sound effects will be applied to high-definition 96KHz/192KHz content.

---



No	Item	Description
1	<b>GX Mode</b>	DirectSound 3D Game Extensions mode supports EAX and DirectSound 3D Hardware extensions for many DirectX/ DirectSound3D games on Windows® Vista and Windows® XP.
2	<b>Hi-Fi Mode</b>	This mode enables Hi-Fidelity playback, where all effects will be cleared to keep the original digital data and analog output quality as high as possible.

## 6.9 VocalFX

VocalFX is an innovative voice processing technology that can immerse your voice in a realistic game landscape (VoiceEX) or imitate background scenes while chatting online (ChatEX). It also allows you to change your voice pitch to disguise who you are (Magic Voice).

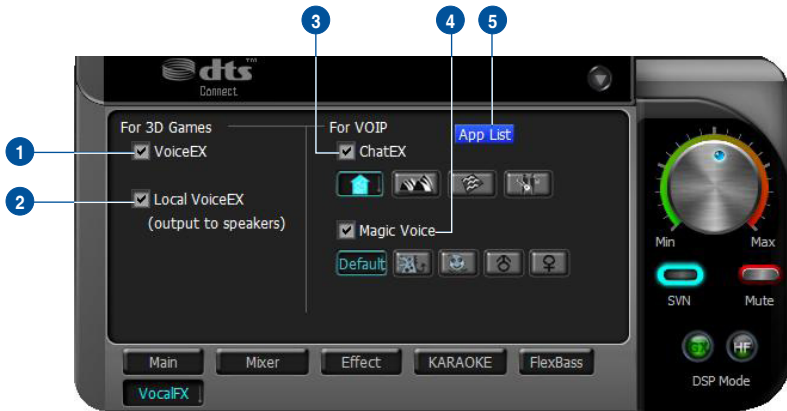

No	Item	Description
1	VoiceEX	Produces realistic and dynamic environmental reverberation for your voice in 3D gaming communication.
2	Local VoiceEX	Produces realistic and dynamic environmental reverberation for your voice in 3D gaming communication over the speakers.
3	ChatEX	Emulates different background environment effects when you chat online.
4	Magic Voice	Changes your voice pitch to different voice types to disguise your real voice or just for fun while chatting online.
5	App List	VOIP applications can be added to the VOIP application list.

### For 3D Games

1. Tick the check box of VoiceEX and Local VoiceEX.
2. Make sure you and your team member can talk to each other in the game.

### For VOIP

1. Click the **App List** button.
2. If your VOIP application is not displayed on the list, press **Add**. (Ensure that Skype and MSN Messenger are the latest versions)

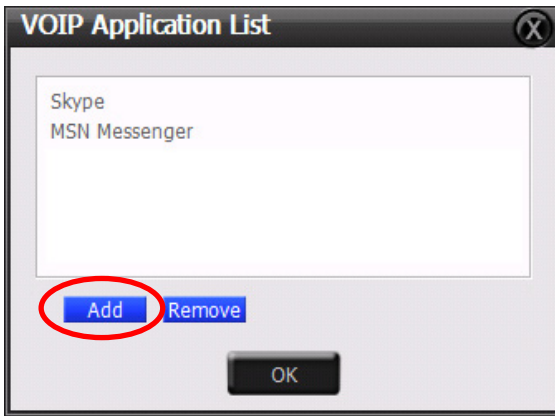

3. Navigate to the VOIP application and click **Open**.

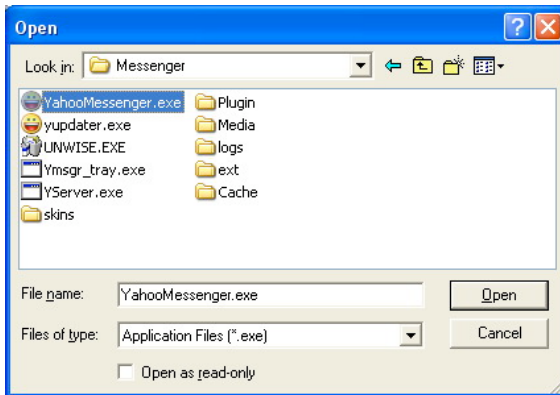

4. The VOIP application will be added to the list.

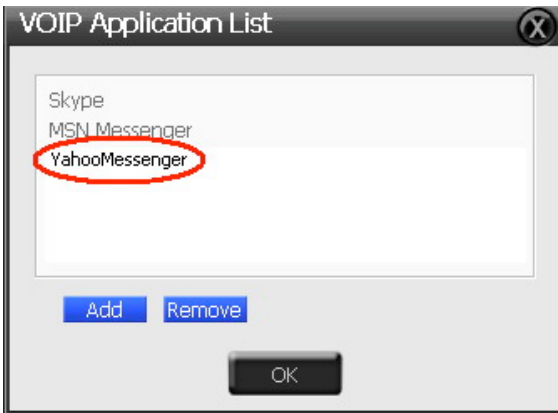

5. Tick the check box for ChatEX and Magic Voice.
6. ChatEX and Magic Voice will be enabled for use when you chat online.



---

The following message appears when you enable the VocalFX feature:

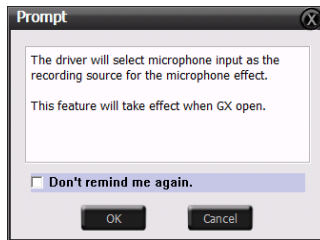

The record device will be set to microphone. Make sure the GX function is enabled. Click **OK** to accept, or **Cancel** if you want to enable the setting later. Check **Don't remind me again** to prevent the message from being displayed again.

---

## 7. Troubleshooting and FAQs

### Troubleshooting

**The audio card driver could not be installed on my PC.**

**Instructions:**

1. Make sure that you have properly plugged the audio card in the PCIE slot on your motherboard.
2. Check that the Windows hardware device manager has discovered a multimedia audio device. If no device is found, try scanning for new hardware.
3. Reboot your system.
4. Remove the card, plug it into another PCIE slot, and try again.

**I cannot find the Xonar DSX Audio Center**

**Instructions:**

1. Make sure you have installed the driver
2. Locate the Xonar DSX Audio Center icon in the system tray found at the bottom right-hand corner of the screen. Double-click the icon to open the Xonar DSX Audio Center utility.



3. If the icon is not on the system tray, go to the Windows Control Panel and double click the "Xonar DSX Audio Center" icon to make it visible in the system tray.
4. After the driver installation is complete, it's recommended that you reboot your computer to complete setup. If the icon still doesn't appear, reinstall the device drivers.

**I cannot hear any sound from my analog speakers**

**Instructions:**

1. Ensure that you have connected the speakers properly and have powered on your speakers.
2. Ensure that the device master volume or the software player has NOT been muted on the Xonar DSX Audio Center.
3. If you are using the DTS encoder through the S/PDIF output, the analog output will be muted to get rid of the interference between your digital speaker system and analog speakers or headphones. Check if this setting is enabled.



4. Go to the sound and audio device settings found in Windows Control Panel to check if the playback default device is set to Xonar DSX Audio Device instead of other onboard AC97 or HDA codec device. If a different device is set, select Xonar DSX Audio Device and restart your system.
5. Reboot your system.

### **I cannot hear any sound from the S/PDIF output**

#### **Instructions:**

1. Ensure that you have enabled S/PDIF output in the Audio Center GUI (Main page).
2. Ensure that you are connecting the correct S/PDIF output jack on the card to the decoder's (AV receiver) S/PDIF input jack.
3. You may need to select the correct input and mode of your decoder or AV receiver. For DTS output, you may have to check that the AV receiver is set to DTS decoding mode.
4. If you are using 192KHz PCM output, please make sure your decoder can support 192KHz decoding. Try changing it to 44.1K or 48KHz first.

### **I cannot hear audio input (Mic, Line-in, AUX, etc.) from my speakers**

#### **Instructions:**

1. Go to the mixer recording page in the Audio Center and select the correct input as the recording source. If you are using Windows® Vista, go to the system audio control panel settings to check if the current default recording/input device is correct.
2. Remember to turn on the digital monitoring button for that recording source.

### **I cannot hear the TV tuner audio from my speakers**

#### **Instructions:**

1. If you are using a traditional TV tuner card with an analog audio output, connect the card to the Aux-In header on the audio card.
2. Select Aux-In as the recording source and switch on the digital monitoring button on the recording mixer page.
3. If you are using a TV tuner card with digital audio output instead of analog, check that the sound is not muted and whether other applications can play sound out. If you still have problems, refer to the TV tuner card's software user guide.

## FAQ

### **Q1: Does the Xonar DSX support Windows® Vista?**

#### **Answer:**

Yes, the Xonar DSX driver package does support Windows® Vista 32/64 bit and most key features are available. In addition, Xonar DSX supports unique DS3D on Windows® Vista, which can recover DirectSound 3D hardware and EAX gaming sound effects on Vista for a lot of existing DirectX games.

### **Q2: Why does the Xonar DSX support DTS technology?**

#### **Answer:**

DTS is the well-known brand and technology recognized by the CE industry and available on a wide range of audio equipment. Moreover, DTS Digital Surround 5.1 audio can deliver better high-quality sound than Dolby Digital. Xonar includes these features to make your PC a powerful media and entertainment center.

### **Q3: Why is Xonar DSX the best audio card for HTPC and multi-channel speakers?**

#### **Answer:**

The Xonar DSX supports DTS Interactive, which allows a single digital connection to your AV receiver to carry DTS Digital Surround audio. In addition, Xonar DSX also provides DTS Neo:PC to upmix TV audio and other types of audio to multi-channel surround sound in Home Theater environments. Xonar DSX also has High Fidelity SNR at 192K/24bit which is only available in high-quality consumer audio cards. The Xonar is therefore the best card to deliver high-quality audio through an analog connection to your home theater system or high-end multi-channel speakers.

### **Q4: Does the Xonar DSX support EAX on Windows® Vista?**

#### **Answer:**

Yes, Xonar DSX can support EAX2.0 not only on Windows® XP but also on Windows® Vista through DirectSound3D Game EXTensions v2.5 (DS3D GX 2.5) technology.

### **Q5: Why do I need DTS for PC games?**

#### **Answer:**

DTS Interactive and Neo:PC are available on the latest game consoles, like XBOX360 and PS3. DTS can provide the best gaming sound experience and compatibility with home theater or TV systems.

**Q6: What is the most important benefit of the Xonar DSX for musicians?**

**Answer:**

1. Ultimate Fidelity: Xonar DSX has the highest quality of audio in/out for the cleanest sound production.
2. Duplex HD: Supports audio sampling rates up to 24bit/192KHz for output and 24bit/96KHz for input.
3. ASIO 2.0: Xonar DSX includes an ASIO 2.0 driver for low-latency, low-distortion music creation application.

**Q7: Is PCM sound output through S/PDIF limited to 2-channels even with different analog output channels?**

**Answer:**

The S/PDIF protocol specification (IEC-60958) can only carry 2-channel PCM data or non-PCM AC3/DTS data. When a user selects PCM output for S/PDIF, the Xonar sound card will always deliver 2-channel PCM data through the S/PDIF output port. For attaining 5.1 channel surround sounds, you can select DTS Interactive encoding output from the S/PDIF out menu, which will allow the Xonar DSX to deliver up to 7.1 surround sound for games, DVD movies, and even stereo music.

**Q8: Why can I hear and record sound from other recording devices when Wave/Digital is selected in Record on Windows® Vista?**

**Answer:**

Unlike Windows® XP, Windows® Vista manages multiple audio devices and audio streams, identifying them as either digital input or analog input. This system allows for multiple recording devices to run simultaneously in Windows® Vista. Wave In or SPDIF-In, considered as a digital input, is an independent recording device from Analog Devices such as Mic In, Line In, or Aux In. Therefore, if you have analog input other than Wave In in use and set to be monitored, you are able to hear and even record sound from those analog devices even if Wave In / SPDIF-In is selected as the default recording device.

Turn off the monitoring function for analog input devices if you only prefer to hear and record Wave In / SPDIF-In sound.

**Q9: Why are sound effects not available when playing 96K or 192KHz sound sources?**

**Answer:**

The sound effects feature on the Xonar DSX currently supports standard 44.1K and 48KHz sound sources. However, users are assured of high fidelity playback for 96K sound sources. This is the common setup professional audiophiles and musicians prefer.

Sound effects can still be applied using commercial or free audio editing software (Ableton Live, Cakewalk, CoolEdit, Soundforge, etc.) to convert the sound files to 48KHz. Please note that the frequency meter on the Xonar DSX Audio Center will not take effect when the playback source is at a 96KHz sample rate to prevent any processing distortion.



## **ASUS Contact information**

### **ASUSTeK COMPUTER INC.**

Address 15 Li-Te Road, Peitou, Taipei, Taiwan 11259  
Telephone +886-2-2894-3447  
Fax +886-2-2890-7798  
E-mail [info@asus.com.tw](mailto:info@asus.com.tw)  
Web site <http://www.asus.com>

#### **Technical Support**

Telephone +86-21-3842-9911  
Fax +86-21-5866-8722, ext. 9101#  
Online support <http://support.asus.com/techserv/techserv.aspx>

### **ASUS COMPUTER INTERNATIONAL (America)**

Address 800 Corporate Way, Fremont, CA 94539, USA  
Telephone +1-510-739-3777  
Fax +1-510-608-4555  
Web site <http://usa.asus.com>

#### **Technical Support**

Support fax +1-812-284-0883  
General support +1-812-282-2787  
Online support <http://support.asus.com/techserv/techserv.aspx>

### **ASUS COMPUTER GmbH (Germany and Austria)**

Address Harkort Str. 21-23, 40880 Ratingen, Germany  
Fax +49-2102-959931  
Web site <http://www.asus.com/de>  
Online contact <http://eu-rma.asus.com/sales>

#### **Technical Support**

Telephone +49-2102-5789555  
Fax +49-2102-959911  
Online support <http://support.asus.com/techserv/techserv.aspx>