

E18098

First Edition / May 2021

IN SEARCH OF INCREDIBLE



Service Manual

ASUS

COPYRIGHT INFORMATION

No part of this manual, including the products and software described in it, may be reproduced, transmitted, transcribed, stored in a retrieval system, or translated into any language in any form or by any means, except documentation kept by the purchaser for backup purposes, without the express written permission of ASUSTeK COMPUTER INC. ("ASUS").

ASUS PROVIDES THIS MANUAL "AS IS" WITHOUT WARRANTY OF ANY KIND, EITHER EXPRESS OR IMPLIED, INCLUDING BUT NOT LIMITED TO THE IMPLIED WARRANTIES OR CONDITIONS OF MERCHANTABILITY OR FITNESS FOR A PARTICULAR PURPOSE. IN NO EVENT SHALL ASUS, ITS DIRECTORS, OFFICERS, EMPLOYEES OR AGENTS BE LIABLE FOR ANY INDIRECT, SPECIAL, INCIDENTAL, OR CONSEQUENTIAL DAMAGES (INCLUDING DAMAGES FOR LOSS OF PROFITS, LOSS OF BUSINESS, LOSS OF USE OR DATA, INTERRUPTION OF BUSINESS AND THE LIKE), EVEN IF ASUS HAS BEEN ADVISED OF THE POSSIBILITY OF SUCH DAMAGES ARISING FROM ANY DEFECT OR ERROR IN THIS MANUAL OR PRODUCT.

Products and corporate names appearing in this manual may or may not be registered trademarks or copyrights of their respective companies, and are used only for identification or explanation and to the owners' benefit, without intent to infringe.

SPECIFICATIONS AND INFORMATION CONTAINED IN THIS MANUAL ARE FURNISHED FOR INFORMATIONAL USE ONLY, AND ARE SUBJECT TO CHANGE AT ANY TIME WITHOUT NOTICE, AND SHOULD NOT BE CONSTRUED AS A COMMITMENT BY ASUS. ASUS ASSUMES NO RESPONSIBILITY OR LIABILITY FOR ANY ERRORS OR INACCURACIES THAT MAY APPEAR IN THIS MANUAL, INCLUDING THE PRODUCTS AND SOFTWARE DESCRIBED IN IT.

Copyright © 2021 ASUSTeK COMPUTER INC. All Rights Reserved.

LIMITATION OF LIABILITY

Circumstances may arise where because of a default on ASUS' part or other liability, you are entitled to recover damages from ASUS. In each such instance, regardless of the basis on which you are entitled to claim damages from ASUS, ASUS is liable for no more than damages for bodily injury (including death) and damage to real property and tangible personal property; or any other actual and direct damages resulted from omission or failure of performing legal duties under this Warranty Statement, up to the listed contract price of each product.

ASUS will only be responsible for or indemnify you for loss, damages or claims based in contract, tort or infringement under this Warranty Statement.

This limit also applies to ASUS' suppliers and its reseller. It is the maximum for which ASUS, its suppliers, and your reseller are collectively responsible.

UNDER NO CIRCUMSTANCES IS ASUS LIABLE FOR ANY OF THE FOLLOWING: (1) THIRD-PARTY CLAIMS AGAINST YOU FOR DAMAGES; (2) LOSS OF, OR DAMAGE TO, YOUR RECORDS OR DATA; OR (3) SPECIAL, INCIDENTAL, OR INDIRECT DAMAGES OR FOR ANY ECONOMIC CONSEQUENTIAL DAMAGES (INCLUDING LOST PROFITS OR SAVINGS), EVEN IF ASUS, ITS SUPPLIERS OR YOUR RESELLER IS INFORMED OF THEIR POSSIBILITY.

SERVICE AND SUPPORT

Visit our multi-language website at <https://www.asus.com/support/>

Table of Contents

Disclaimer	4
Safety precautions.....	4
Major components.....	6
Installation tools.....	7
Removing the compartment cover.....	8
Cover screw map	12
Disconnecting the battery	13
Replacing the battery.....	16
Replacing the M.2 SSD module(s).....	21
Replacing the RAM module	24
Replacing the LCD module (Clamshell model)	28
Replacing the LCD module (Flip model)	39
Replacing the motherboard	44
Wiring and connection diagrams	53

Disclaimer

ASUS is not responsible for direct, indirect, intentional or unintentional damages resulting from improper installation and operation.

Safety precautions

- Keep liquids or moisture away from your Notebook PC before installing or removing any components.
- Ensure to place your Notebook PC on a stable surface before installing or removing any components.
- Detach the clip or flap before removing the signal cables to prevent damage.
- Disconnect the power plug by pulling the plug evenly to avoid damage. Ensure to connect the signal cables in the correct orientation.
- Disconnect all power cables and remove the battery pack (if applicable) before cleaning your Notebook PC with liquid detergent to avoid risk of electric shock.
- Disconnect all power cables and remove the battery pack (if applicable) before installing or removing any components. Ensure to read and follow the instructions in the manual.

- Before handling components, use a grounded wrist strap or touch a safely grounded object to avoid damaging them due to static electricity.
- Keep liquids or moisture away from your Notebook PC to avoid short circuits.
- Hold components by the edges to avoid touching the ICs.
- Ensure to properly install all the components before connecting the AC power.
- Do not use power adapters or batteries from other devices to reduce the risk of injury to persons due to fire or explosion. Use only certified power adapters or batteries supplied by the manufacturer or authorized retailers.
- Ensure to install the correct screw models on your Notebook PC to prevent damage.

Major components

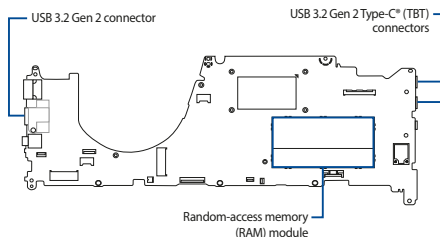

Motherboard with ports and connectors



M.2 SSD module

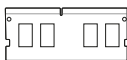

RAM module

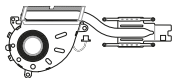

Cooling radiator



Keyboard (Top case module)

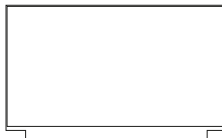

LCD panel module

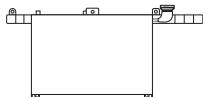

**Battery and power connector
(33W)**

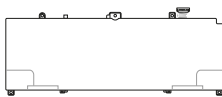

**Battery and power connector
(66W)**

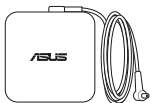

Power adapter

NOTE:

- The illustrations are for reference only.
 - The maintenance procedures described in this manual depend on the model configuration and may not reflect the entire servicing process. For servicing those components that are not covered in this manual, please visit an authorized service center for further assistance.
-

Installation tools



Screwdriver



Plastic blade



Tweezers

Removing the compartment cover

NOTE: The appearance of your Notebook PC's bottom view may vary per model.

- A. Remove the screw(s) from the Notebook PC's compartment cover.

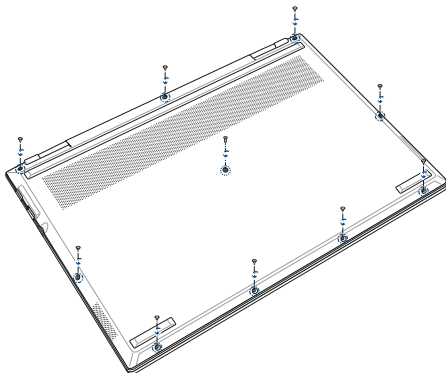

- B. Place your Notebook PC in the orientation as shown in the illustration below.
- C. Use the plastic blade to pry open the indicated area of the compartment cover as shown in the illustration below.

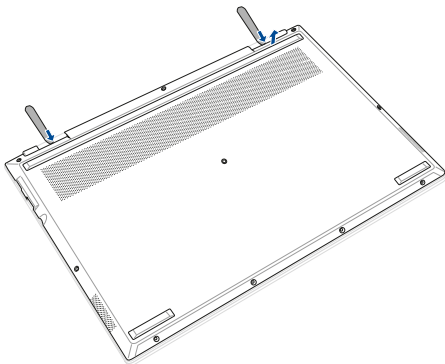

IMPORTANT! Avoid sliding the plastic blade along the side of your Notebook PC to prevent damage.

- D. Remove the compartment cover.

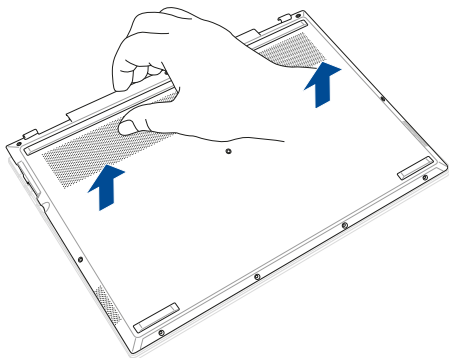

To reattach the compartment cover:

- A. Align and reattach the compartment cover.
- B. Secure the compartment cover using the screw(s) you removed earlier.

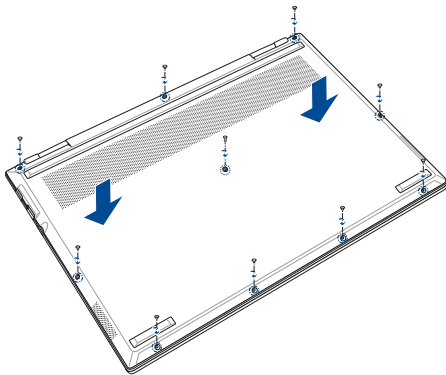

Cover screw map

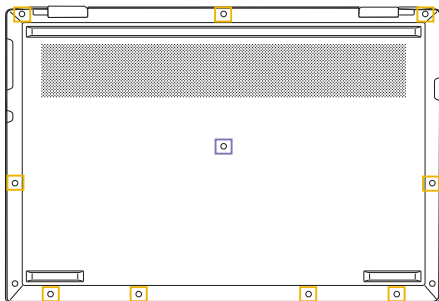

■ M2.0 x 3.0L (9PCS)

■ M2.0 x 7.0L (1PCS)

Disconnecting the battery

- A. Remove the compartment cover.

NOTE: For more details, refer to the *Removing the compartment cover* section in this manual.

- B. Locate and disconnect the battery power cable(s) as shown in the illustration below.

33W model

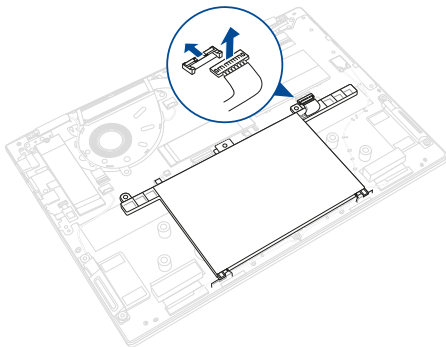

66W model

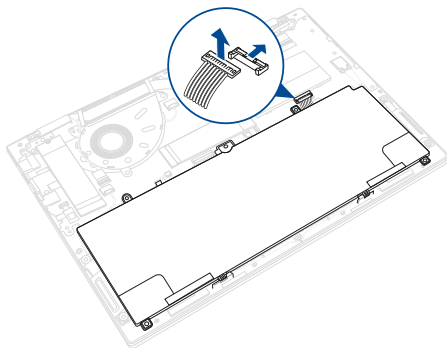

To connect the battery, align and connect the cable to the battery connector before you reattach the compartment cover.

33W model

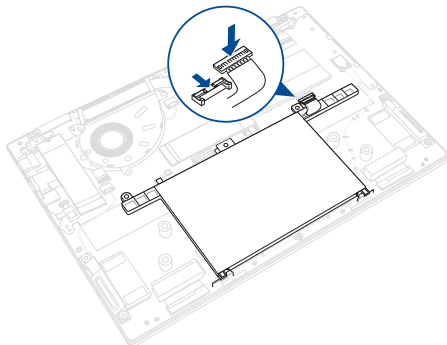

66W model

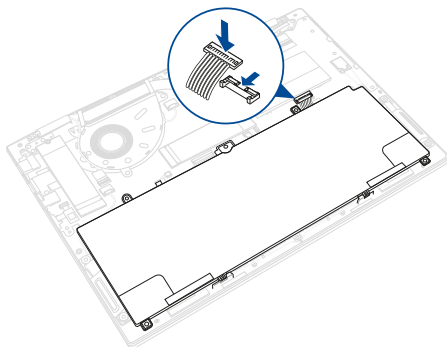

Replacing the battery

Refer to the following steps when installing a compatible battery in your Notebook PC:

IMPORTANT! Purchase your battery from authorized retailers of this Notebook PC to ensure maximum compatibility and reliability.

WARNING! Disconnect all the connected peripherals, any telephone or telecommunication lines and power connector (such as external power supply, battery pack, etc.) before removing the compartment cover.

NOTE:

- The appearance of your Notebook PC's bottom view and battery may vary per model but the module installation remains the same.
 - It is recommended that you install the battery under professional supervision. You may also visit an authorized service center for further assistance.
-

- A. Remove the compartment cover and disconnect the battery.

NOTE: For more details, refer to the *Removing the compartment cover* and *Disconnecting the battery* sections in this manual.

- B. Remove the screw(s) from the battery.

33W model

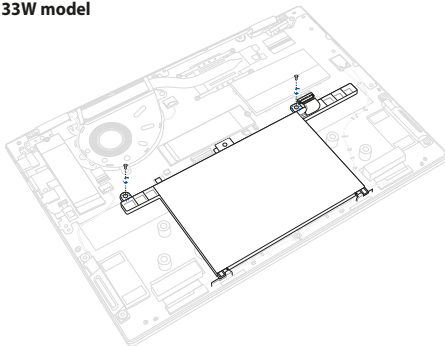

66W model

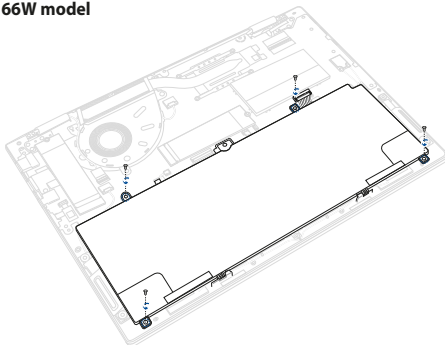

- C. Remove the battery.

33W model

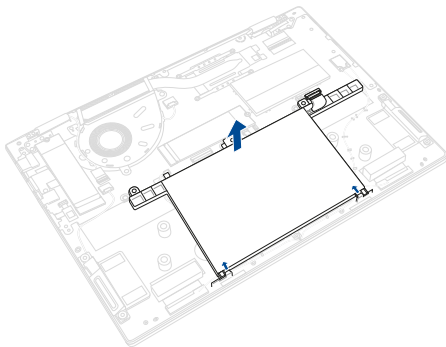

66W model

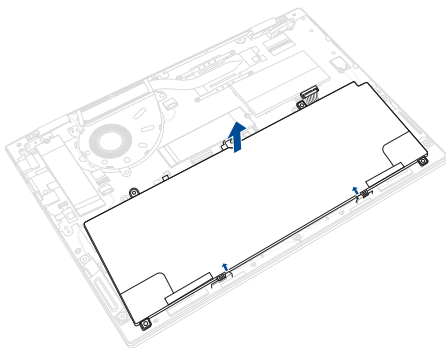

- D. Prepare the new battery.
- E. Reinstall the battery.

33W model

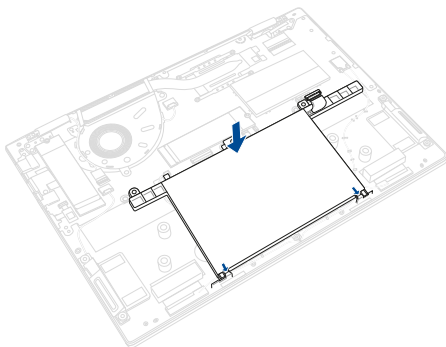

66W model

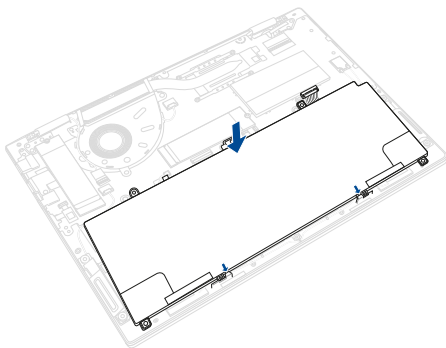

- F. Secure the battery using the screw(s) you removed earlier.

33W model

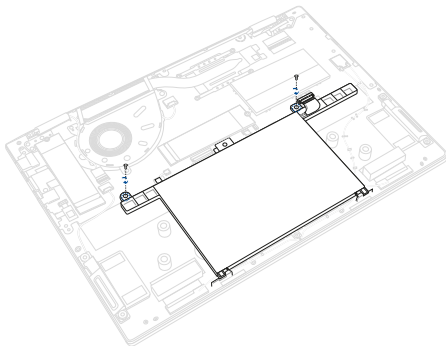

66W model

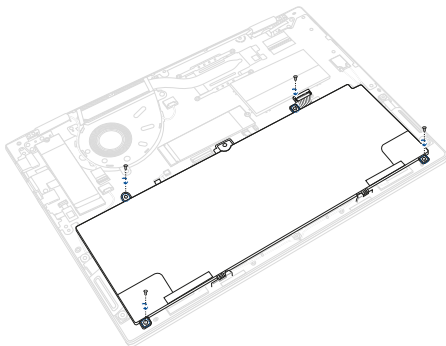

Replacing the M.2 SSD module(s)

Refer to the following steps when installing a compatible M.2 SSD module in your Notebook PC:

IMPORTANT! Purchase your M.2 SSD module from authorized retailers of this Notebook PC to ensure maximum compatibility and reliability.

WARNING! Disconnect all the connected peripherals, any telephone or telecommunication lines and power connector (such as external power supply, battery pack, etc.) before removing the compartment cover.

NOTE:

- The appearance of your Notebook PC's bottom view and M.2 SSD module may vary per model but the module installation remains the same.
 - It is recommended that you install the M.2 SSD module under professional supervision. You may also visit an authorized service center for further assistance.
-

- A. Remove the compartment cover and disconnect the battery.

NOTE: For more details, refer to the *Removing the compartment cover* and *Disconnecting the battery* sections in this manual.

- B. Remove the screw(s) from the M.2 SSD module(s).
- C. Remove the M.2 SSD module(s) from the motherboard.

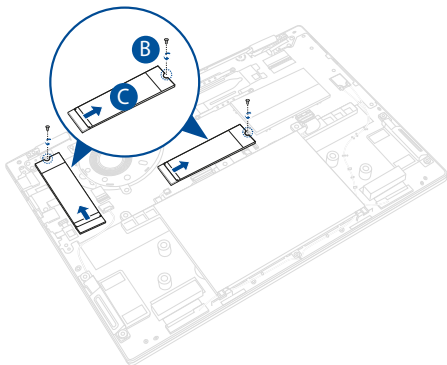

- D. Remove the shielding case(s) from the M.2 SSD module(s).

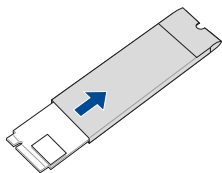

- E. Prepare the new M.2 SSD module(s).
- F. Install the shielding case(s) into the M.2 SSD module(s).

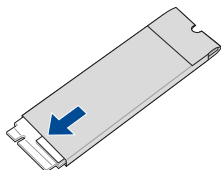

- G. Align and insert the M.2 SSD module(s) into the M.2 connector(s) on the motherboard.
- H. Secure the M.2 SSD module(s) in place using the screw(s) you removed earlier.

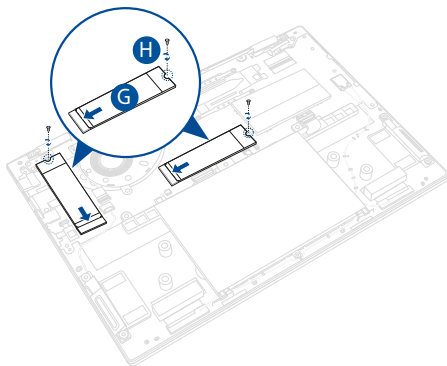

Replacing the RAM module

Upgrade the memory capacity of your Notebook PC by installing a RAM (Random Access Memory) module in the memory module compartment. Refer to the following steps when installing a RAM module in your Notebook PC:

IMPORTANT! Visit an authorized service center or retailer for information on RAM module upgrades for your Notebook PC. Purchase your RAM modules from authorized retailers of this Notebook PC to ensure maximum compatibility and reliability.

WARNING! Disconnect all the connected peripherals, any telephone or telecommunication lines and power connector (such as external power supply, battery pack, etc.) before removing the compartment cover.

NOTE:

- The appearance of your Notebook PC's bottom view and RAM module may vary per model but the RAM module installation remains the same.
 - It is recommended that you install the RAM module under professional supervision. You may also visit an authorized service center for further assistance.
-

A. Remove the compartment cover and disconnect the battery.

NOTE: For more details, refer to the *Removing the compartment cover* and *Disconnecting the battery* sections in this manual.

- B. Use the plastic blade to pry the RAM module cover and then remove it from the motherboard.

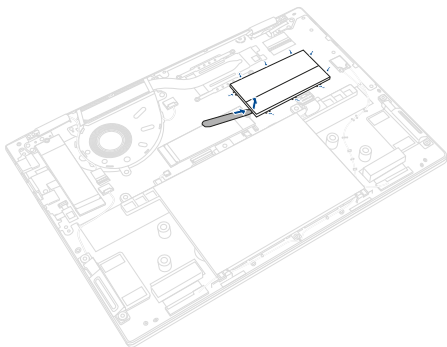

- C. Push the clips outwards to release the RAM module.

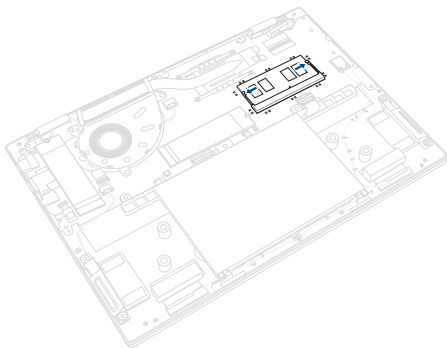

- D. Remove the RAM module from the RAM module slot.

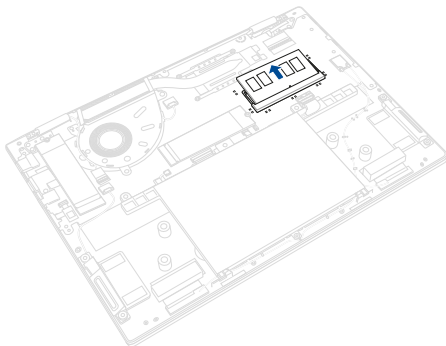

- E. Prepare the new RAM module.
- F. Align and insert the RAM module into the RAM module slot.

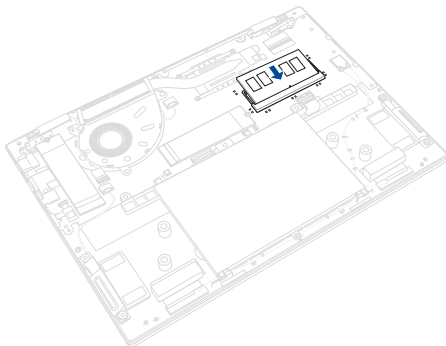

- G. Push down the RAM module until it clicks into place.

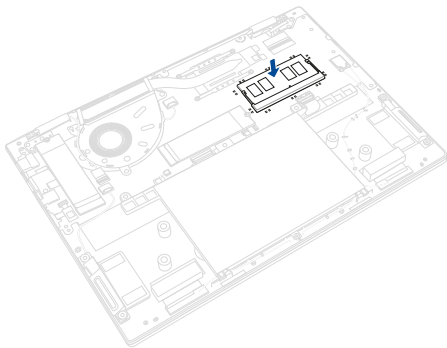

- H. Reinstall the RAM module cover.

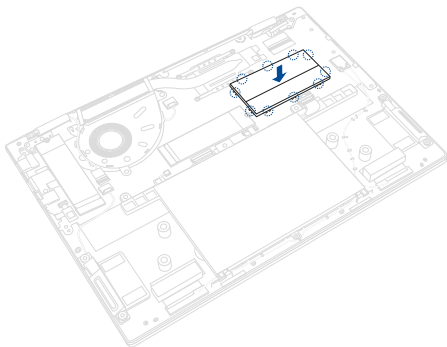

Replacing the LCD module (Clamshell model)

IMPORTANT! Do not bend the LCD panel in any ways to avoid risk of LCD panel leakage.

NOTE: The illustrations are for reference only.

- A. Remove the compartment cover and disconnect the battery.
-

NOTE: For more details, refer to the *Removing the compartment cover* and *Disconnecting the battery* sections in this manual.

- B. Place your Notebook PC in the orientation as shown in the illustration below.

- C. Locate and disconnect all the cable(s) as shown in the illustration below.

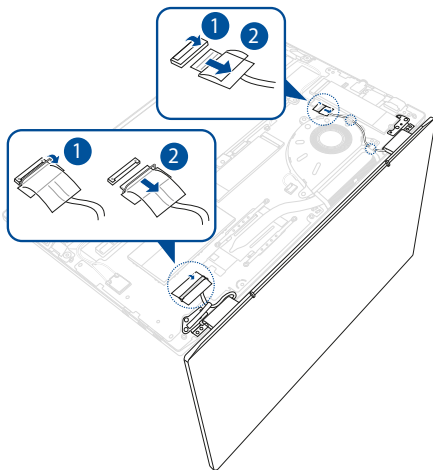

- D. Remove the screw(s) from the hinges, and then remove the LCD panel module.

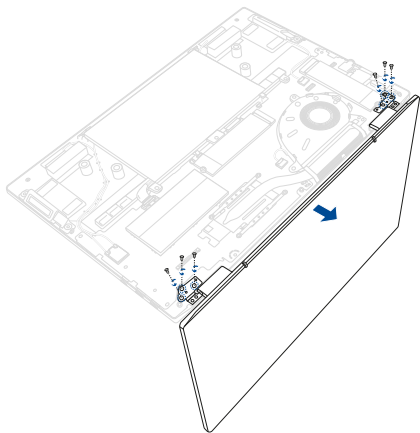

- E. Pry loose the bottom side of the bezel first, then continue with the left, right, and top sides of the bezel. **DO NOT** remove the bezel!

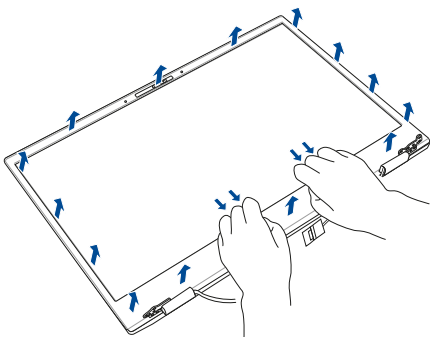

- F. Release the eDP cable from the LCD hinge cap. Then remove the LCD bezel.

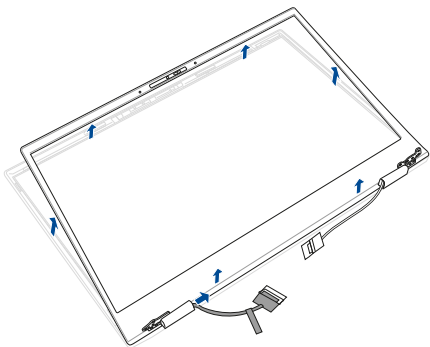

- G. Locate the tip of the adhesive strips near the bottom area of the display panel.
- H. Carefully pull the adhesive strips out one part at a time as shown in the illustration below.

IMPORTANT! Avoid pulling the adhesive strips with excessive force or the adhesive strips might break.

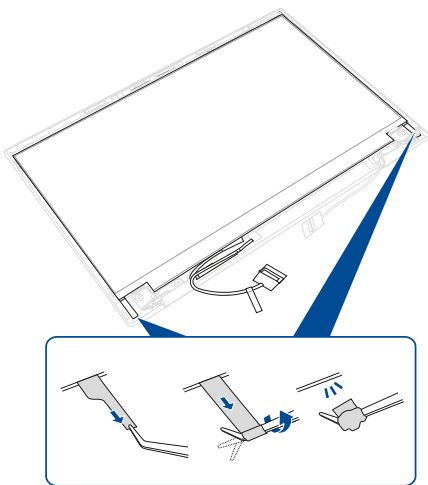

- I. Remove the LCD panel. Then locate and disconnect the eDP cable as shown in the illustration below.

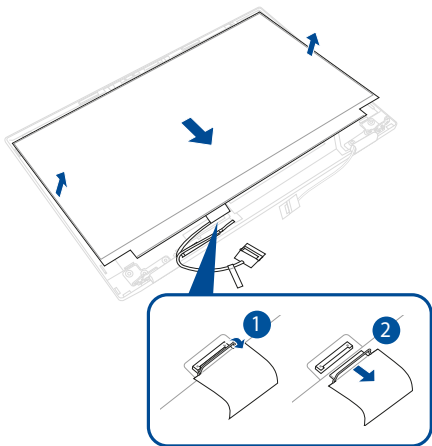

- J. Prepare the new adhesive strips.
- K. Remove the release liner underneath the adhesive strips.
- L. Align and apply the adhesive strips as shown in the illustration below.

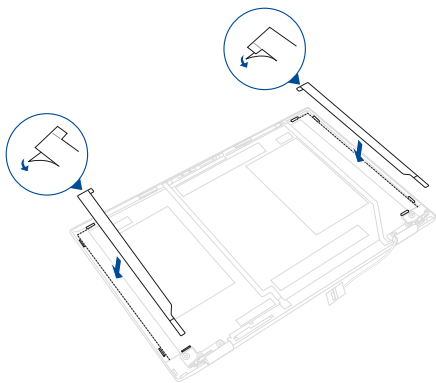

- M. Remove the release liner above the adhesive strips.

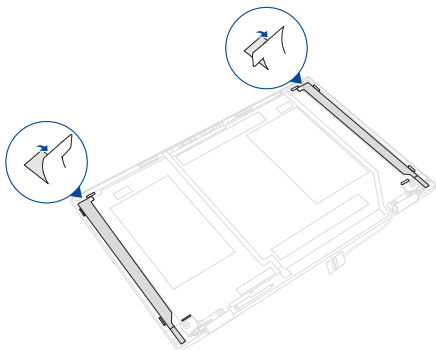

- N. Prepare the new LCD panel module.

- O. Align and place the new LCD panel module in the orientation as shown in the illustration below.

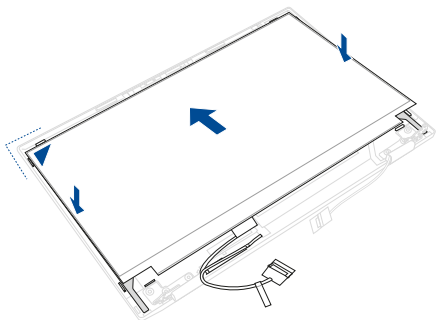

- P. Prepare the new LCD bezel.
- Q. Remove the release liner underneath the LCD bezel.

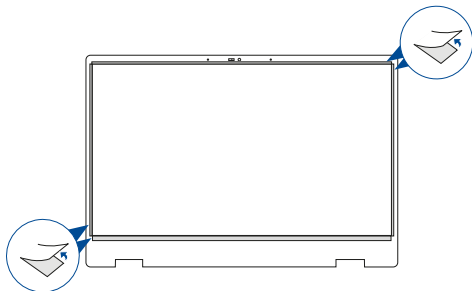

- R. Install the eDP cable into the LCD hinge cap as shown in the illustration below.
- S. Align and gently reattach the bezel onto its slot on the bottom side of the LCD panel module. Continue reattaching upward along the left and right sides. Finally, reattach the top side.

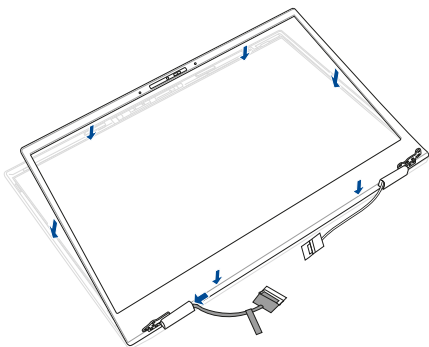

- T. In the orientation shown, align and place the hinges of the display module on the screw holes on the chassis.
- U. Secure the LCD panel module using the screw(s) you removed earlier.

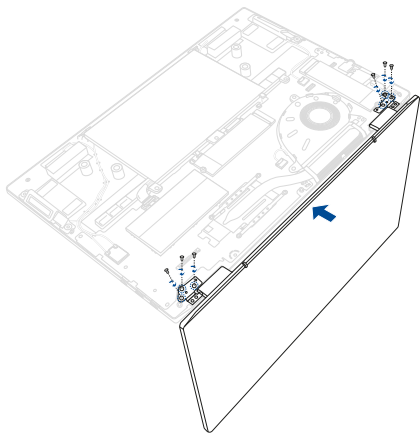

V. Reconnect all the cable(s) as shown in the illustration below.

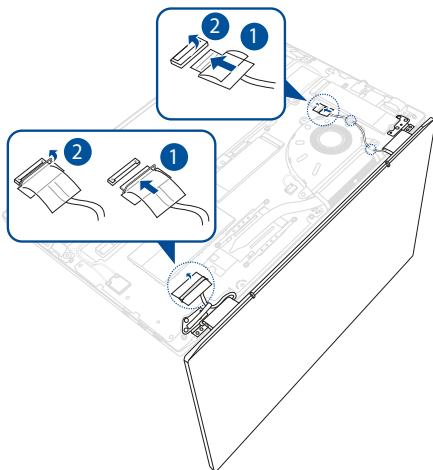

Replacing the LCD module (Flip model)

IMPORTANT! Do not bend the LCD panel in any ways to avoid risk of LCD panel leakage.

NOTE: The illustrations are for reference only.

- A. Remove the compartment cover and disconnect the battery.
-

NOTE: For more details, refer to the *Removing the compartment cover* and *Disconnecting the battery* sections in this manual.

- B. Place your Notebook PC in the orientation as shown in the illustration below.

- C. Locate and disconnect all the cable(s) as shown in the illustration below.

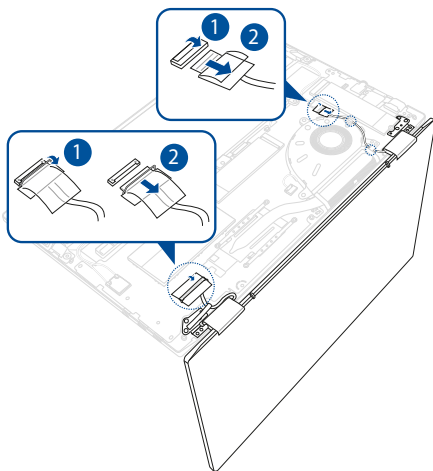

- D. Remove the screw(s) from the hinges, and then remove the LCD panel module.

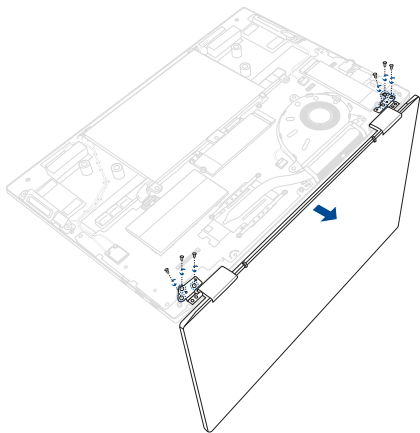

- E. Prepare the new LCD panel module.
- F. In the orientation shown, align and place the hinges of the display module on the screw holes on the chassis.
- G. Secure the LCD panel module using the screw(s) you removed earlier.

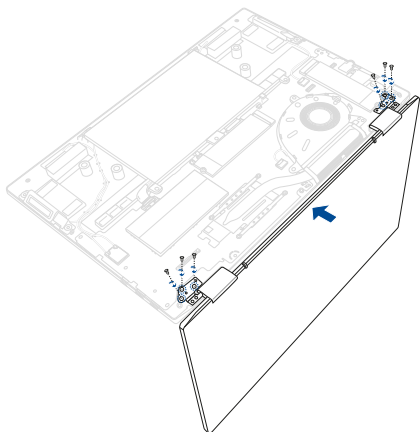

H. Reconnect all the cable(s) as shown in the illustration below.

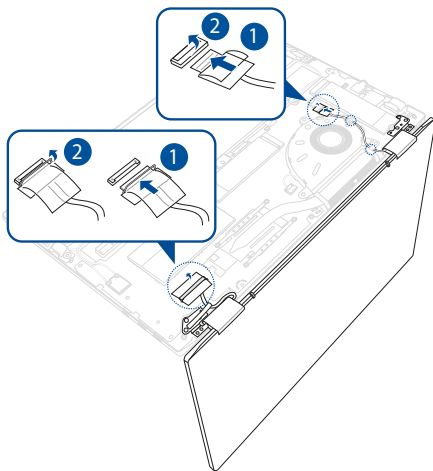

Replacing the motherboard

Refer to the following steps when installing the motherboard to your Notebook PC:

IMPORTANT! Purchase your motherboard from authorized retailers of this Notebook PC to ensure maximum compatibility and reliability.

WARNING! Disconnect all the connected peripherals, any telephone or telecommunication lines and power connector (such as external power supply, battery pack, etc.) before removing the compartment cover.

NOTE:

- The appearance of your Notebook PC's bottom view and motherboard may vary per model but the module installation remains the same.
 - It is recommended that you install the motherboard under professional supervision. You may also visit an authorized service center for further assistance.
-

- A. Remove the compartment cover, disconnect the battery, and remove the LCD panel module.

NOTE: For more details, refer to the *Removing the compartment cover*, *Disconnecting the battery*, and *Replacing the LCD module (Clamshell model) / Replacing the LCD module (Flip model)* sections in this manual.

- B. Locate and disconnect all the cable(s) as shown in the illustration below.
- C. Unroute the touch and speaker cables from the cable guides.

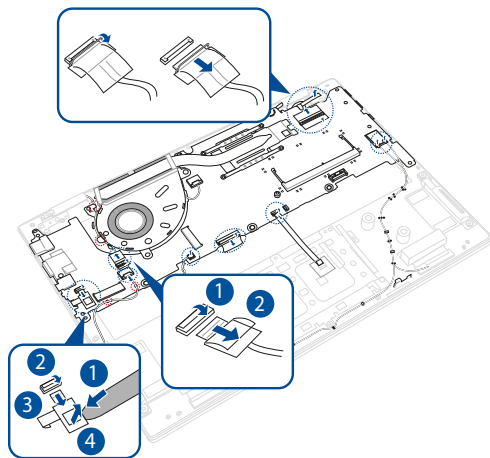

- D. Remove the screw(s) from the fan.

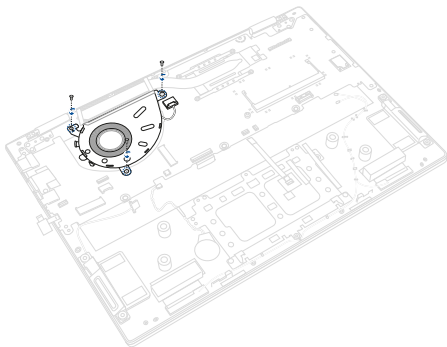

- E. Disconnect the fan cable. Then remove the fan from the chassis.

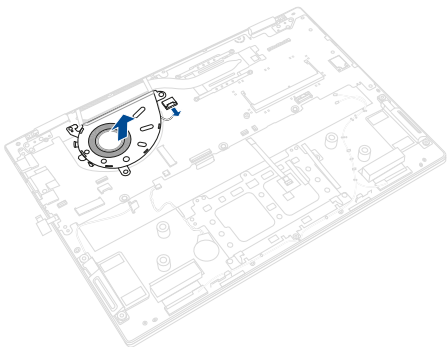

- F. Remove the screw(s) from the motherboard.

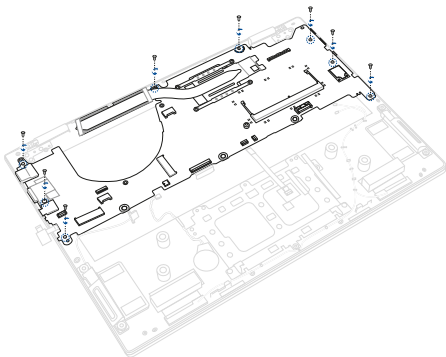

- G. Release the motherboard I/O connectors from the I/O slots on the chassis and then remove the motherboard.

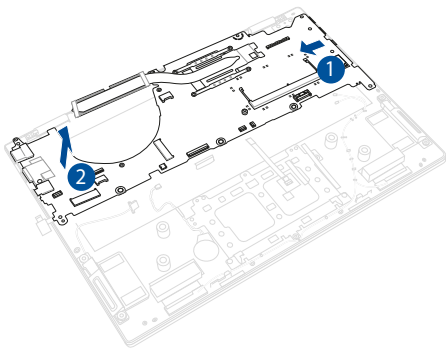

- H. Remove the screw(s) from the cooling radiator.

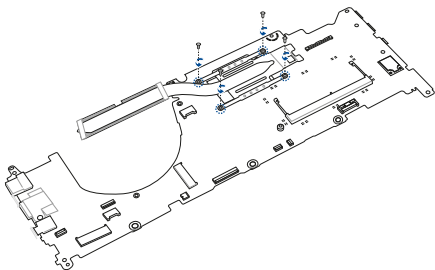

- I. Remove the cooling radiator from the motherboards.

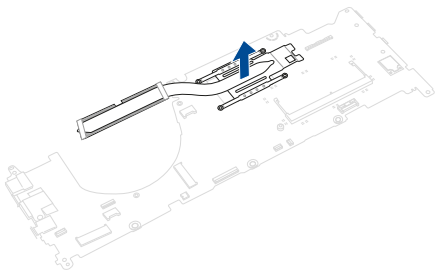

- J. Prepare the new motherboard.
- K. Align and replace the cooling radiator on the screw holes of the motherboard.

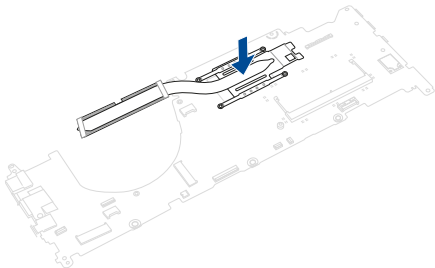

- L. Secure the screw(s) one by one in the sequence as shown in the illustration below.

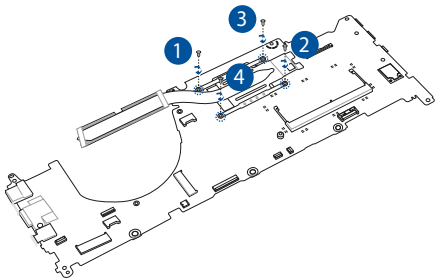

- M. Align and insert the motherboard I/O connectors into the I/O connectors on the chassis. Then lower the motherboard back in the chassis.

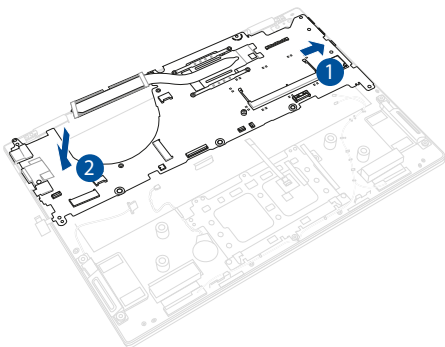

- N. Secure the motherboard using the screw(s) you removed earlier.

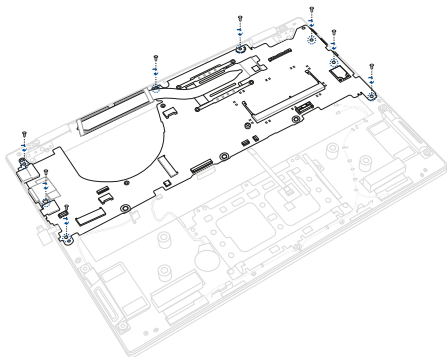

- O. Align and place the fan back in the chassis. Then connect the fan cable.

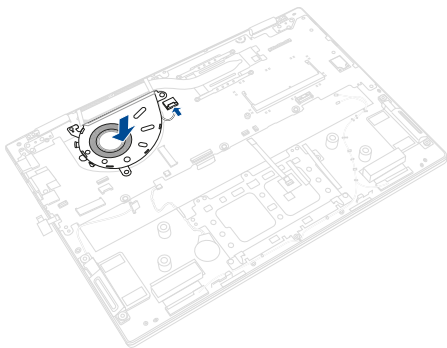

- P. Secure the fan using the screw(s) you removed earlier.

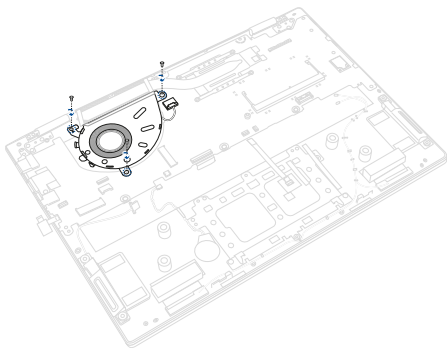

- Q. Route the touch and speaker cables through the cable guides.
- R. Reconnect all the connector(s) disconnected earlier.

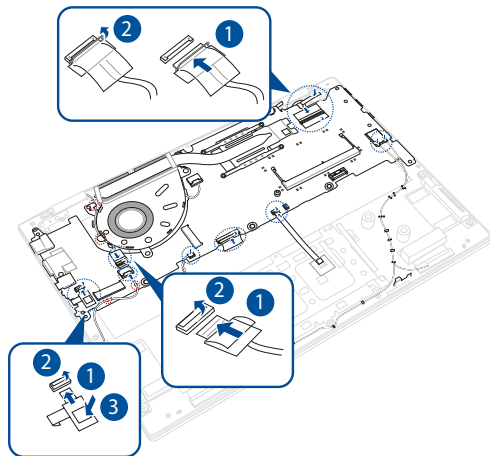

Wiring and connection diagrams

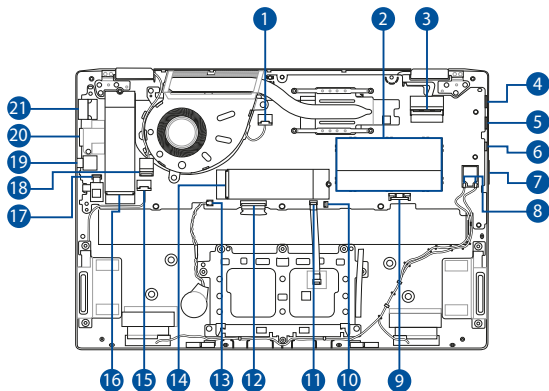

Top View

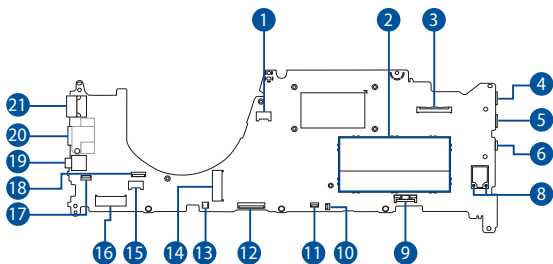

Bottom View

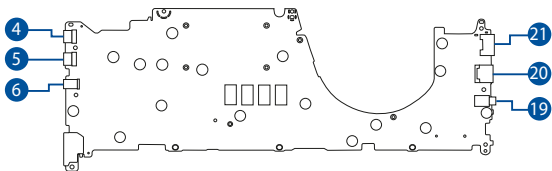

- | | |
|--|---------------------------------------|
| 1. Fan connector | 11. Touchpad connector |
| 2. Random-access memory (RAM) module | 12. Keyboard connector |
| 3. eDP connector | 13. RTC battery connector |
| 4. USB 3.2 Gen 2 Type-C® (TBT) connector | 14. M.2 SSD 1 st connector |
| 5. USB 3.2 Gen 2 Type-C® (TBT) connector | 15. Speaker connector |
| 6. Micro HDMI connector (for LAN) | 16. M.2 SSD 2 nd connector |
| 7. Volume switch | 17. Fingerprint connector |
| 8. Wifi connector | 18. LED and Touch connector |
| 9. Battery power connector | 19. Headphone/Headset/Microphone jack |
| 10. Keyboard backlight connector | 20. USB 3.2 Gen 2 connector |
| | 21. HDMI connector |