

E18695

First Edition / August 2021

IN SEARCH OF INCREDIBLE



Service Manual

ASUS

COPYRIGHT INFORMATION

No part of this manual, including the products and software described in it, may be reproduced, transmitted, transcribed, stored in a retrieval system, or translated into any language in any form or by any means, except documentation kept by the purchaser for backup purposes, without the express written permission of ASUSTeK COMPUTER INC. ("ASUS").

ASUS PROVIDES THIS MANUAL "AS IS" WITHOUT WARRANTY OF ANY KIND, EITHER EXPRESS OR IMPLIED, INCLUDING BUT NOT LIMITED TO THE IMPLIED WARRANTIES OR CONDITIONS OF MERCHANTABILITY OR FITNESS FOR A PARTICULAR PURPOSE. IN NO EVENT SHALL ASUS, ITS DIRECTORS, OFFICERS, EMPLOYEES OR AGENTS BE LIABLE FOR ANY INDIRECT, SPECIAL, INCIDENTAL, OR CONSEQUENTIAL DAMAGES (INCLUDING DAMAGES FOR LOSS OF PROFITS, LOSS OF BUSINESS, LOSS OF USE OR DATA, INTERRUPTION OF BUSINESS AND THE LIKE), EVEN IF ASUS HAS BEEN ADVISED OF THE POSSIBILITY OF SUCH DAMAGES ARISING FROM ANY DEFECT OR ERROR IN THIS MANUAL OR PRODUCT.

Products and corporate names appearing in this manual may or may not be registered trademarks or copyrights of their respective companies, and are used only for identification or explanation and to the owners' benefit, without intent to infringe.

SPECIFICATIONS AND INFORMATION CONTAINED IN THIS MANUAL ARE FURNISHED FOR INFORMATIONAL USE ONLY, AND ARE SUBJECT TO CHANGE AT ANY TIME WITHOUT NOTICE, AND SHOULD NOT BE CONSTRUED AS A COMMITMENT BY ASUS. ASUS ASSUMES NO RESPONSIBILITY OR LIABILITY FOR ANY ERRORS OR INACCURACIES THAT MAY APPEAR IN THIS MANUAL, INCLUDING THE PRODUCTS AND SOFTWARE DESCRIBED IN IT.

Copyright © 2021 ASUSTeK COMPUTER INC. All Rights Reserved.

LIMITATION OF LIABILITY

Circumstances may arise where because of a default on ASUS' part or other liability, you are entitled to recover damages from ASUS. In each such instance, regardless of the basis on which you are entitled to claim damages from ASUS, ASUS is liable for no more than damages for bodily injury (including death) and damage to real property and tangible personal property; or any other actual and direct damages resulted from omission or failure of performing legal duties under this Warranty Statement, up to the listed contract price of each product.

ASUS will only be responsible for or indemnify you for loss, damages or claims based in contract, tort or infringement under this Warranty Statement.

This limit also applies to ASUS' suppliers and its reseller. It is the maximum for which ASUS, its suppliers, and your reseller are collectively responsible.

UNDER NO CIRCUMSTANCES IS ASUS LIABLE FOR ANY OF THE FOLLOWING: (1) THIRD-PARTY CLAIMS AGAINST YOU FOR DAMAGES; (2) LOSS OF, OR DAMAGE TO, YOUR RECORDS OR DATA; OR (3) SPECIAL, INCIDENTAL, OR INDIRECT DAMAGES OR FOR ANY ECONOMIC CONSEQUENTIAL DAMAGES (INCLUDING LOST PROFITS OR SAVINGS), EVEN IF ASUS, ITS SUPPLIERS OR YOUR RESELLER IS INFORMED OF THEIR POSSIBILITY.

SERVICE AND SUPPORT

Visit our multi-language website at <https://www.asus.com/support/>

Table of Contents

Disclaimer	4
Safety precautions.....	4
Major components.....	6
Installation tools.....	7
Removing the compartment cover.....	8
Disconnecting the battery	15
Replacing the battery.....	17
Replacing the motherboard	22
Replacing the LCD module (Flip model)	38
LCD module screw map	51
Replacing the LCD module (Clamshell model)	53
LCD module screw map	65
Wiring and connection diagrams	67

Disclaimer

ASUS is not responsible for direct, indirect, intentional or unintentional damages resulting from improper installation and operation.

Safety precautions

- Keep liquids or moisture away from your Notebook PC before installing or removing any components.
- Ensure to place your Notebook PC on a stable surface before installing or removing any components.
- Detach the clip or flap before removing the signal cables to prevent damage.
- Disconnect the power plug by pulling the plug evenly to avoid damage. Ensure to connect the signal cables in the correct orientation.
- Disconnect all power cables and remove the battery pack (if applicable) before cleaning your Notebook PC with liquid detergent to avoid risk of electric shock.
- Disconnect all power cables and remove the battery pack (if applicable) before installing or removing any components. Ensure to read and follow the instructions in the manual.

- Before handling components, use a grounded wrist strap or touch a safely grounded object to avoid damaging them due to static electricity.
- Keep liquids or moisture away from your Notebook PC to avoid short circuits.
- Hold components by the edges to avoid touching the ICs.
- Ensure to properly install all the components before connecting the AC power.
- Do not use power adapters or batteries from other devices to reduce the risk of injury to persons due to fire or explosion. Use only certified power adapters or batteries supplied by the manufacturer or authorized retailers.
- Ensure to install the correct screw models on your Notebook PC to prevent damage.

Major components

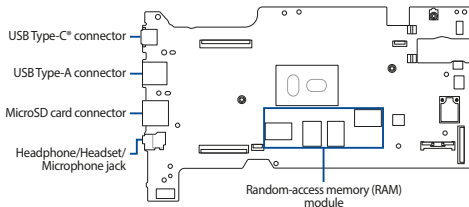

Motherboard with ports and connectors

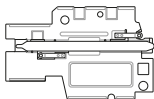

Cooling radiator

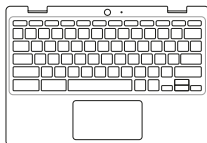

Keyboard (Top case module)

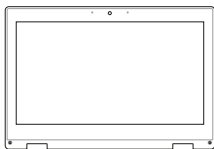

LCD panel module

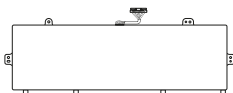

Battery and power connector



Power adapter

NOTE:

- The illustrations are for reference only.
 - The maintenance procedures described in this manual depend on the model configuration and may not reflect the entire servicing process. For servicing those components that are not covered in this manual, please visit an authorized service center for further assistance.
-

Installation tools



Screwdriver



Plastic blade



Tweezers

Removing the compartment cover

NOTE: The appearance of your Notebook PC's bottom view may vary per model.

- A. Loosen the pop-open screw(s) without removing the screw(s) from the Notebook PC's compartment cover.

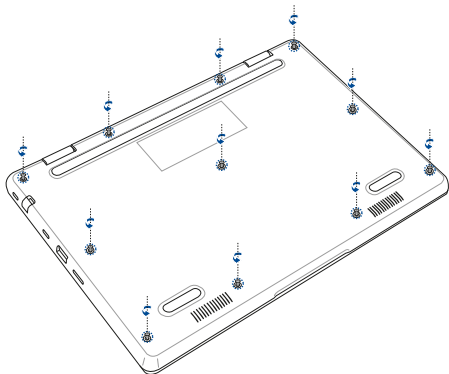

- B. Place your Notebook PC in the orientation as shown in the illustration below.
- C. Use the plastic blade to pry open the indicated area of the compartment cover as shown in the illustration below.

IMPORTANT! Avoid sliding the plastic blade along the side of your Notebook PC to prevent damage.

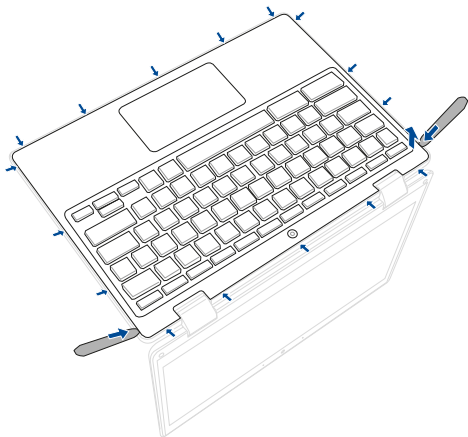

- D. Slightly lift the keyboard (top case module) to access the cable(s).

IMPORTANT! Cable(s) are connected. Avoid damaging the cable connectors when removing the keyboard (top case module).

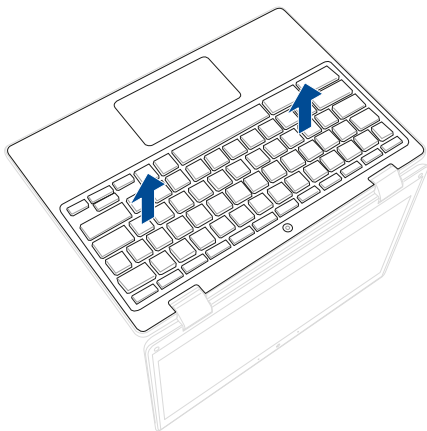

- E. Locate and disconnect the cable(s) and connector(s) as shown in the illustration below.

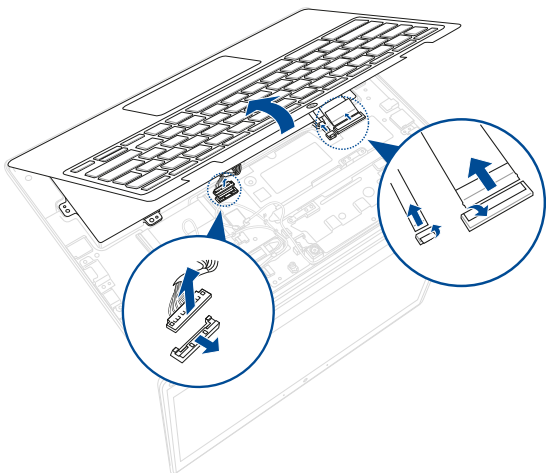

To reattach the compartment cover:

- A. Align and place the keyboard (top case module) on the chassis.
- B. Reconnect all the cable(s) and connector(s) as shown in the illustration below.
- C. Lower the keyboard (top case module) in place.

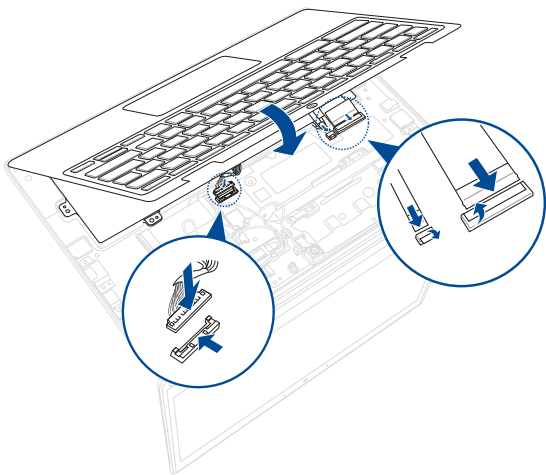

- D. Reattach the keyboard (top case module) to the chassis.

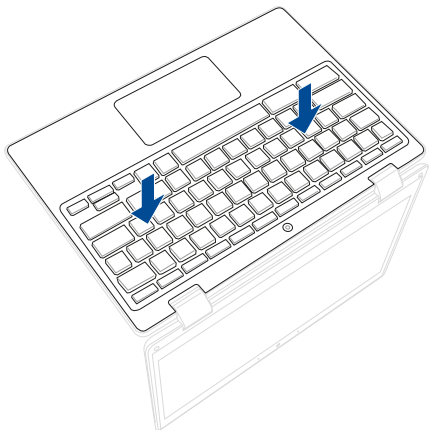

- E. Place your Notebook PC in the orientation as shown in the illustration below.
- F. Tighten the pop-open screw(s) on the compartment cover.

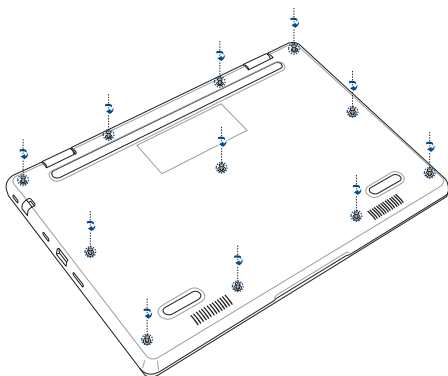

Disconnecting the battery

- A. Remove the compartment cover.

NOTE: For more details, refer to the *Removing the compartment cover* section in this manual.

- B. Locate and disconnect the battery power cable(s) as shown in the illustration below.

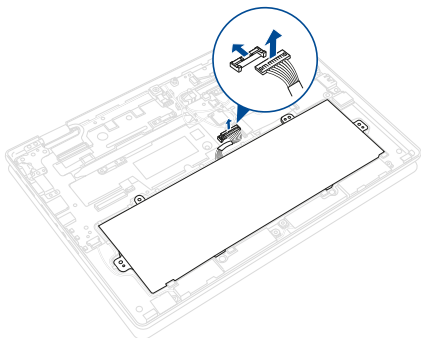

To connect the battery, align and connect the cable to the battery connector before you reattach the compartment cover.

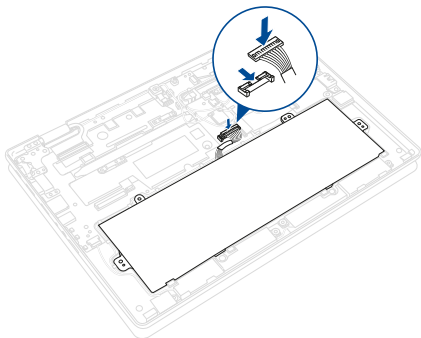

Replacing the battery

Refer to the following steps when installing a compatible battery in your Notebook PC:

IMPORTANT! Purchase your battery from authorized retailers of this Notebook PC to ensure maximum compatibility and reliability.

WARNING! Disconnect all the connected peripherals, any telephone or telecommunication lines and power connector (such as external power supply, battery pack, etc.) before removing the compartment cover.

NOTE:

- The appearance of your Notebook PC's bottom view and battery may vary per model but the module installation remains the same.
 - It is recommended that you install the battery under professional supervision. You may also visit an authorized service center for further assistance.
-

- A. Remove the compartment cover and disconnect the battery.

NOTE: For more details, refer to the *Removing the compartment cover* and *Disconnecting the battery* sections in this manual.

- B. Remove the screw(s) from the battery.

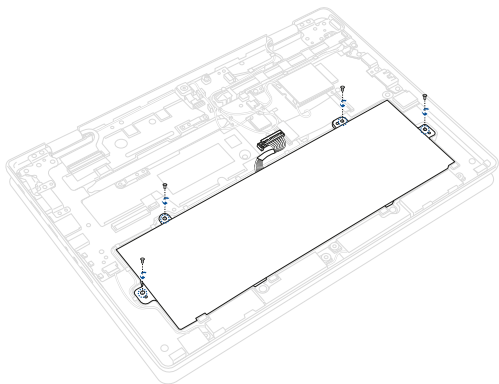

- C. Release the battery from the bottom latches. Then remove the battery.

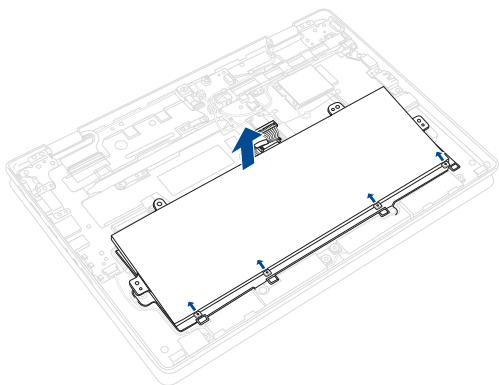

- D. Prepare the new battery.
- E. Slide the battery to the bottom latches. Then lower the battery in place.

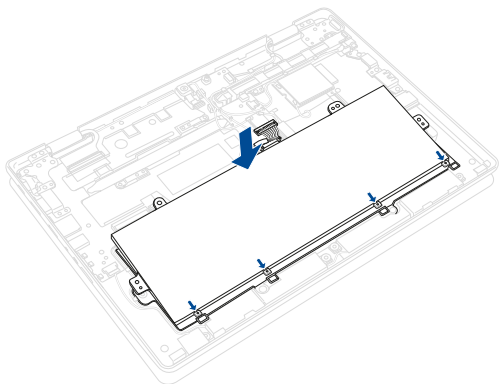

- F. Secure the battery using the screw(s) you removed earlier.

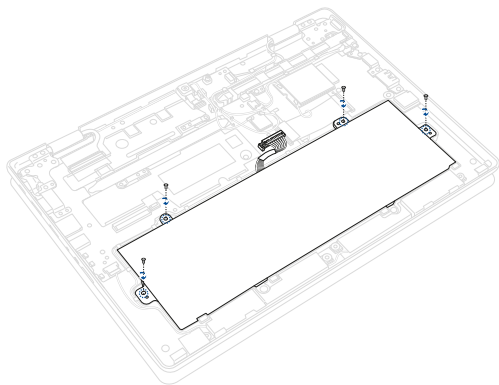

Replacing the motherboard

Refer to the following steps when installing the motherboard to your Notebook PC:

IMPORTANT! Purchase your motherboard from authorized retailers of this Notebook PC to ensure maximum compatibility and reliability.

WARNING! Disconnect all the connected peripherals, any telephone or telecommunication lines and power connector (such as external power supply, battery pack, etc.) before removing the compartment cover.

NOTE:

- The appearance of your Notebook PC's bottom view and motherboard may vary per model but the module installation remains the same.
 - It is recommended that you install the motherboard under professional supervision. You may also visit an authorized service center for further assistance.
-

- A. Remove the compartment cover and disconnect the battery.

NOTE: For more details, refer to the *Removing the compartment cover* and *Disconnecting the battery* sections in this manual.

- B. Place your Notebook PC in the orientation as shown in the illustration below.
- C. Locate and disconnect all the cable(s) as shown in the illustration below.

With LTE model

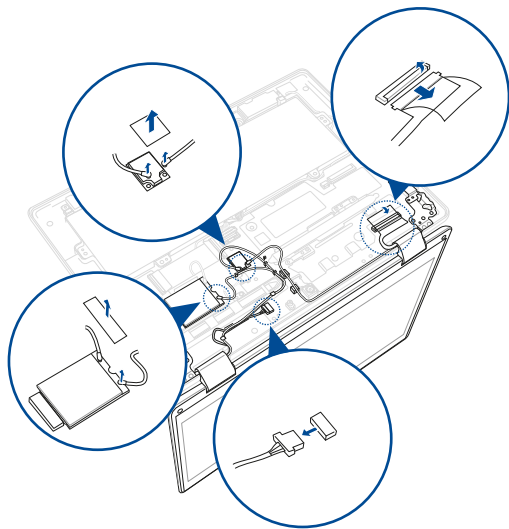

Without LTE model

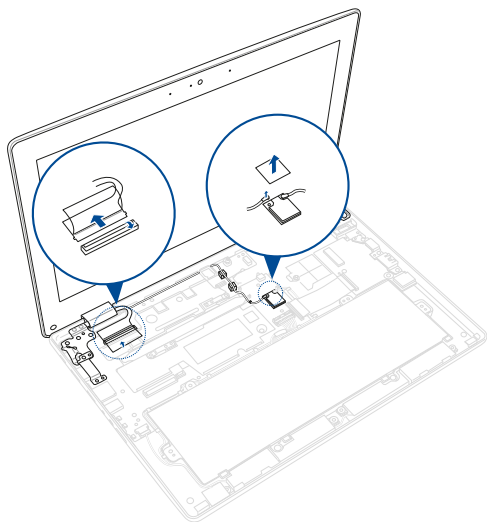

- D. Remove the screw(s) from the hinges and I/O bracket, and then remove the LCD panel module.

With LTE model

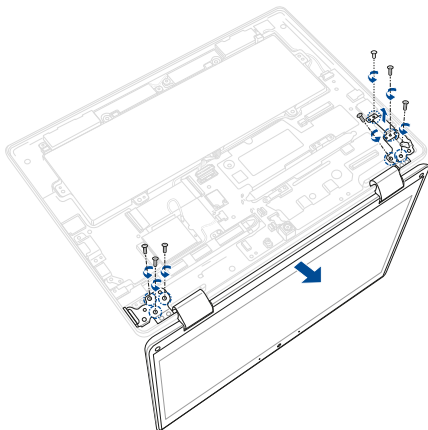

Without LTE model

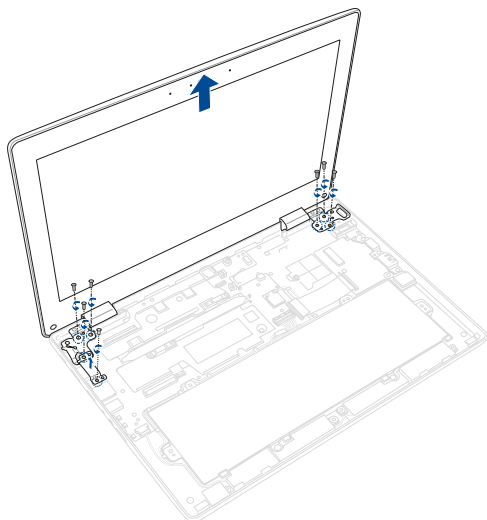

- E. Locate and disconnect all the cable(s) as shown in the illustration below.

With LTE model

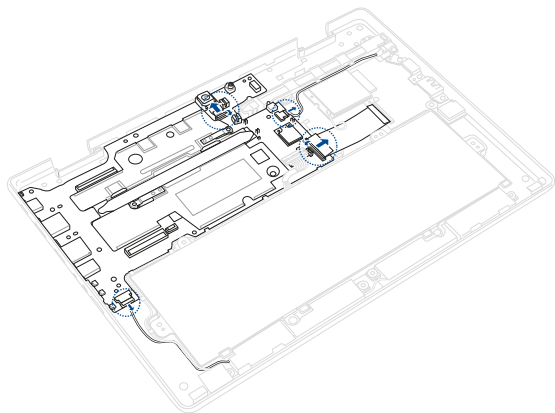

Without LTE model

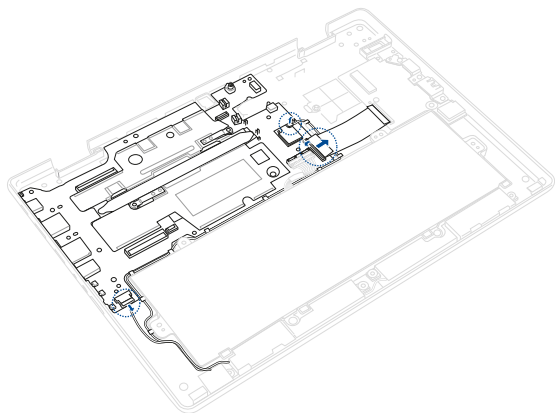

F. Remove the screw(s) from the motherboard.

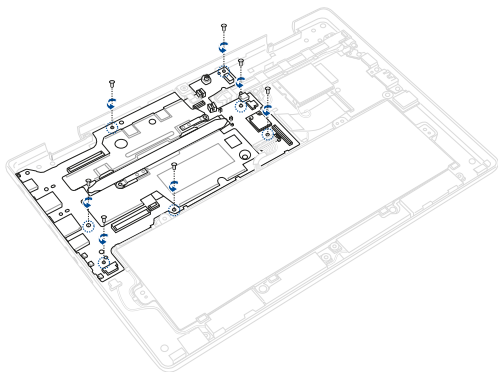

- G. Release the motherboard I/O connectors from the I/O slots on the chassis. Then remove the motherboard.

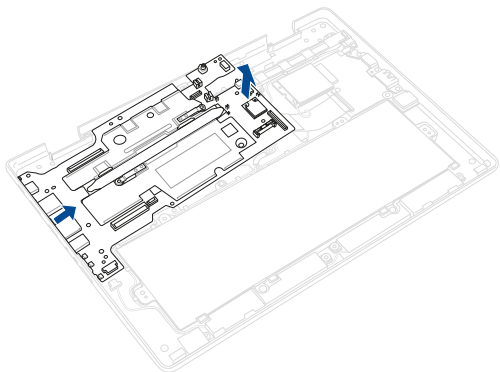

- H. Remove the screw(s) from the cooling radiator.

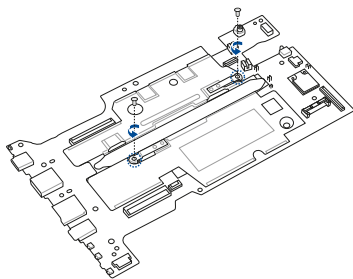

- I. Remove the cooling radiator from the motherboard.

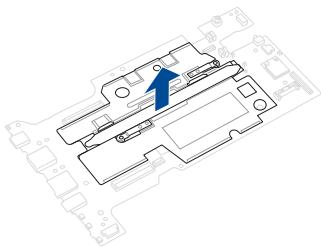

- J. Prepare the new motherboard.

- K. Align and replace the cooling radiator on the screw holes of the motherboard.

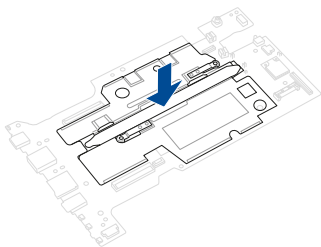

- L. Secure the cooling radiator using the screw(s) you removed earlier.

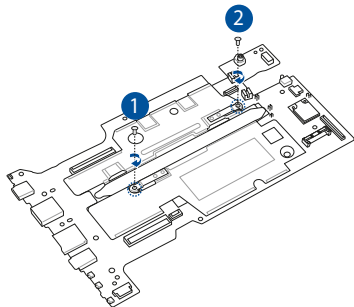

- M. Align and insert the motherboard I/O connectors into the I/O ports on the chassis. Then lower the motherboard back in the chassis.

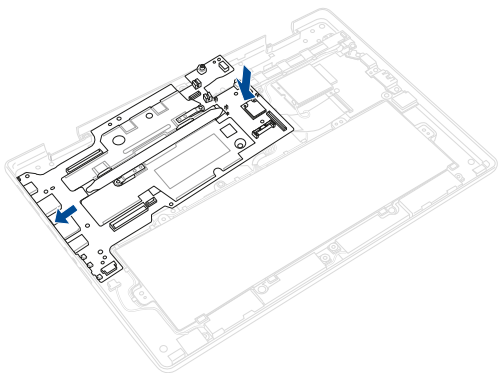

- N. Secure the motherboard using the screw(s) you removed earlier.

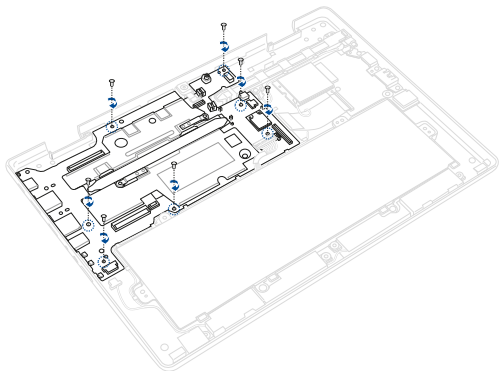

- O. Locate and reconnect all the cable(s).

With LTE model

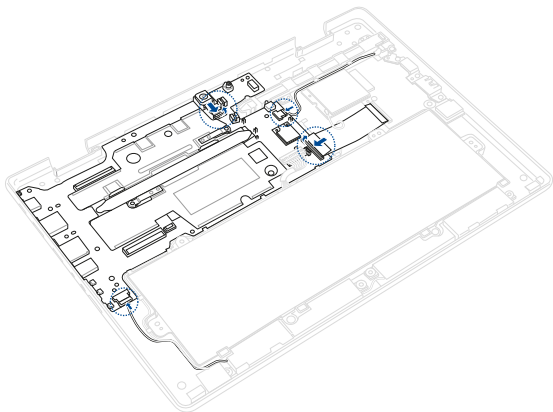

Without LTE model

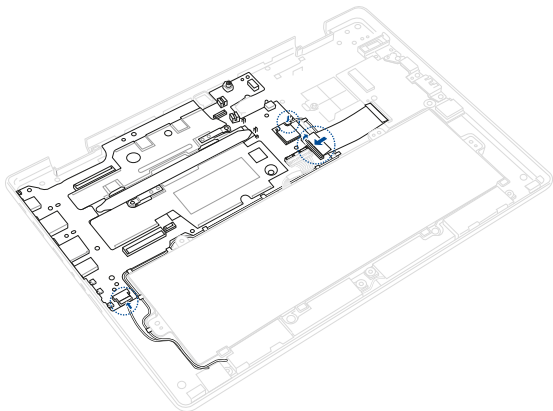

- P. In the orientation shown, align and place the hinges of the display module and I/O bracket on the screw holes on the chassis.
- Q. Secure the LCD panel module using the screw(s) you removed earlier.

With LTE model

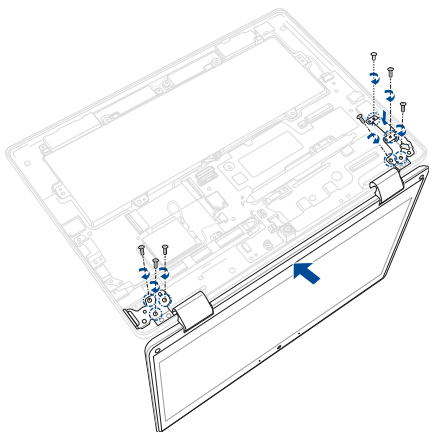

Without LTE model

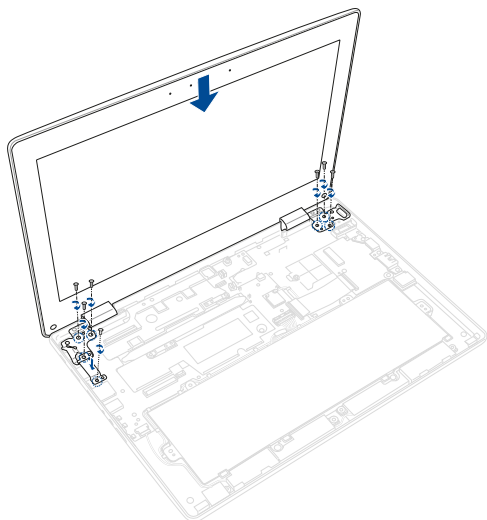

R. Reconnect all the cable(s) as shown in the illustration below.

With LTE model

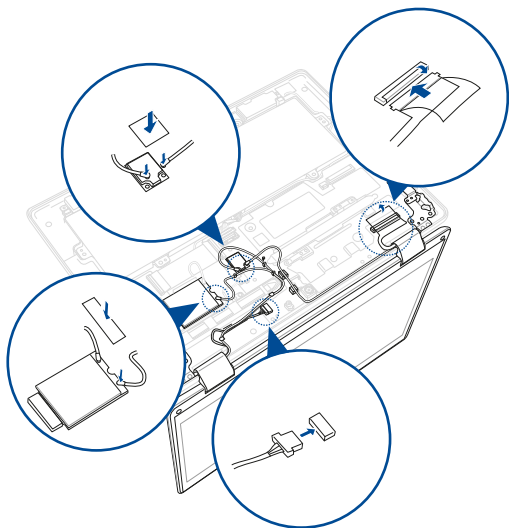

Without LTE model

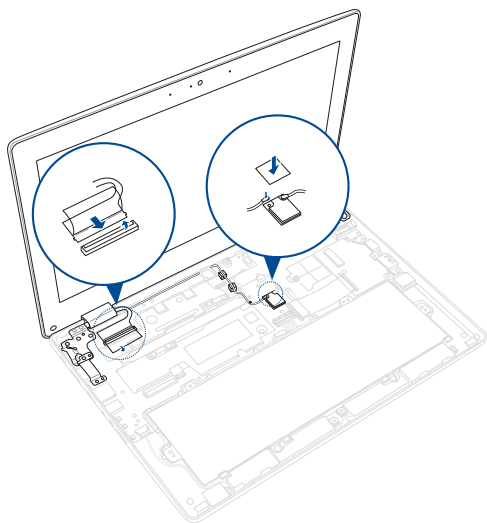

Replacing the LCD module (Flip model)

IMPORTANT! Do not bend the LCD panel module in any ways to avoid risk of LCD panel leakage.

NOTE: The illustrations are for reference only.

- A. Remove the compartment cover and disconnect the battery.
-

NOTE: For more details, refer to the *Removing the compartment cover* and *Disconnecting the battery* sections in this manual.

- B. Locate and disconnect all the cable(s) as shown in the illustration below.

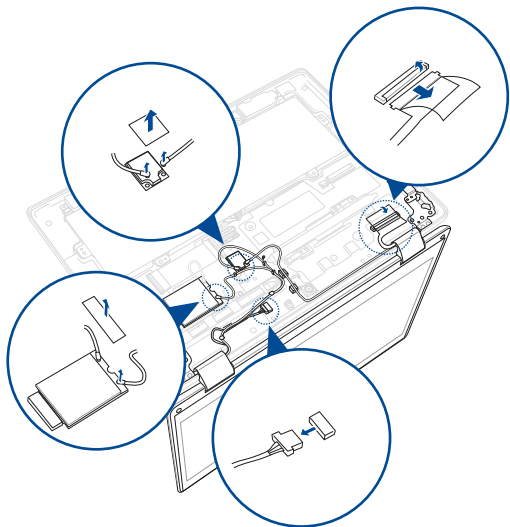

- C. Remove the screw(s) from the hinges and I/O bracket, and then remove the LCD panel module.

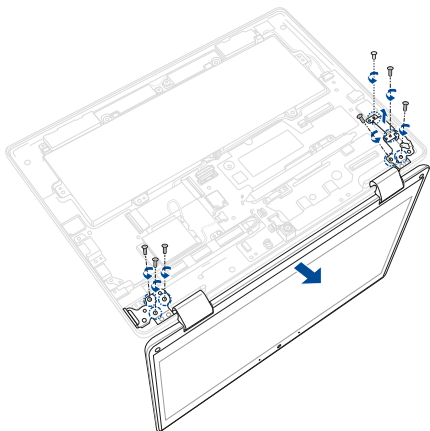

- D. Fold the LCD hinges until 90 degrees.

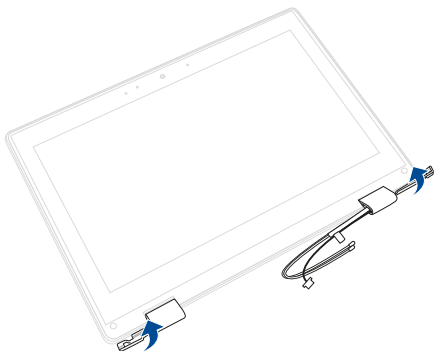

- E. Use the tweezers to remove the screw cap cover(s) from the screw(s) as shown in the illustration below.

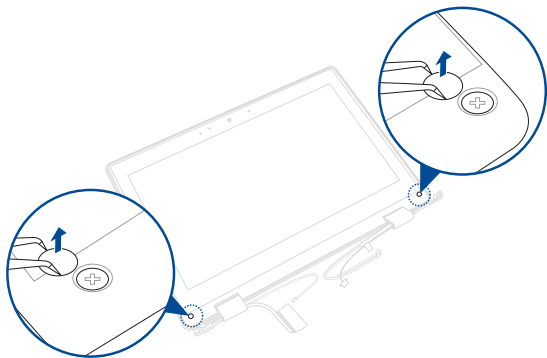

- F. Remove the screw(s) from the LCD panel.

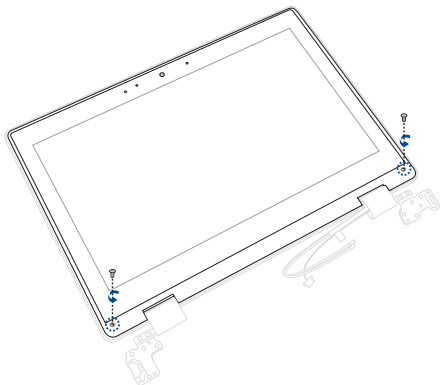

- G. Use the plastic blade to pry loose the LCD panel as shown in the illustration below.

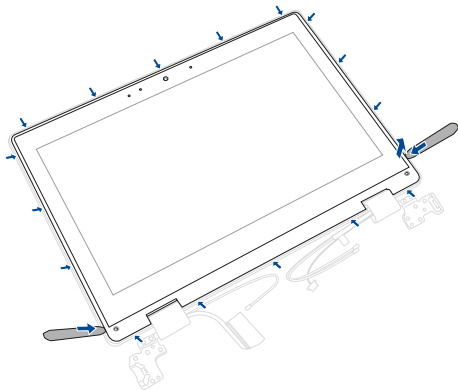

- H. Release the eDP cable from the LCD hinge cap. Then remove the LCD panel.

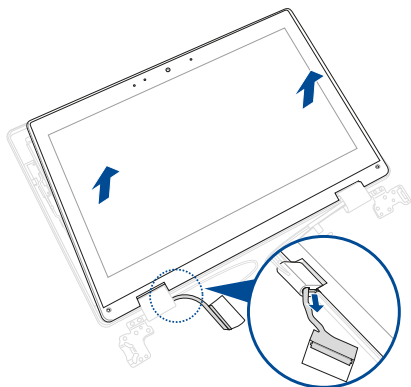

- I. To remove the eDP cable:
 1. Detach the conductive fabric tab from the camera module.
 2. Locate and disconnect the eDP cable as shown in the illustration below.
 3. Unroute the eDP cable from the cable guides and remove from the LCD panel together with the camera module.

NOTE: The eDP cable includes the control board cable, camera cable, and the LCD panel cable.

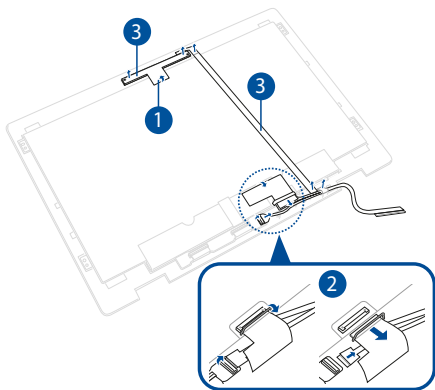

- J. Detach the conductive fabric tab from the LCD panel.
- K. Locate and disconnect the control board cable(s). Then remove the control board.

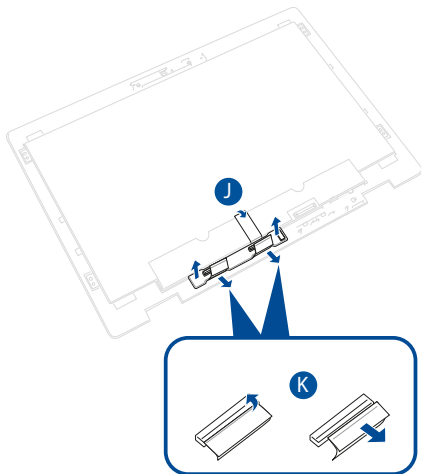

- L. Prepare the new LCD panel.
- M. To install the control board:
 1. Reinstall the control board and attach the conductive fabric tab to the LCD panel.
 2. Reconnect the control board cable(s).

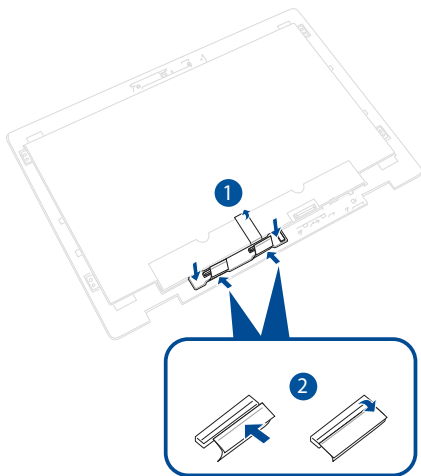

- N. To install the eDP cable to the LCD panel:
1. Place the camera module and the eDP cable back to the LCD panel.
 2. Attach the conductive fabric tab to the camera module.
 3. Route the eDP cable through the cable guides.
 4. Reconnect the eDP cable as shown in the illustration below.

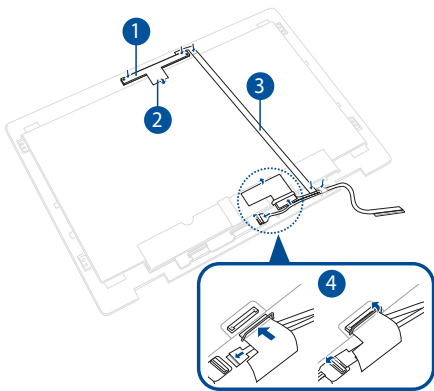

- O. Replace a portion of the eDP cable to the LCD hinge cap. Then align and reinstall the LCD panel.

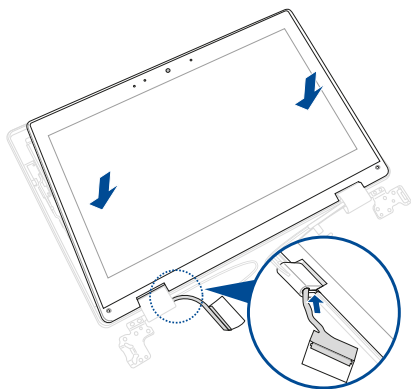

- P. Secure the LCD panel using the screw(s) you removed earlier.

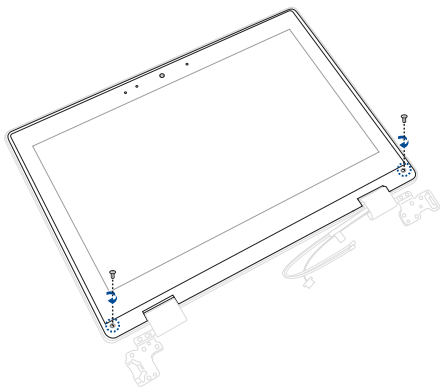

- Q. Use the tweezers to replace the screw cap cover(s) as shown in the illustration below.

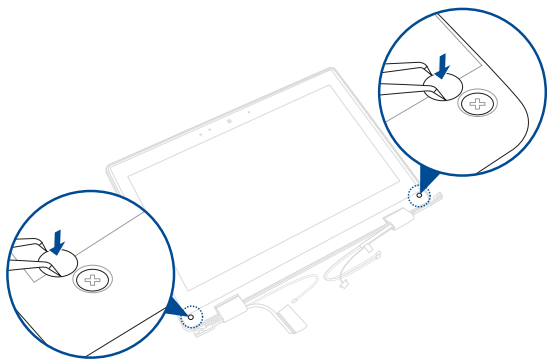

- R. Bend the LCD hinges until 90 degrees.

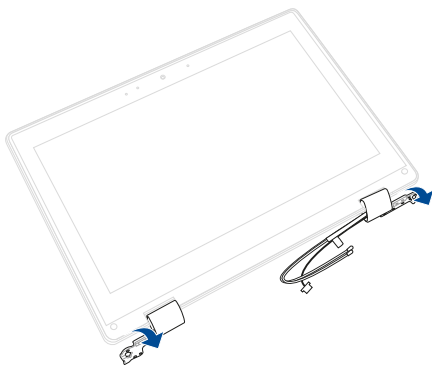

- S. In the orientation shown, align and place the hinges of the display module and I/O bracket on the screw holes on the chassis.
- T. Secure the LCD panel module using the screw(s) you removed earlier.

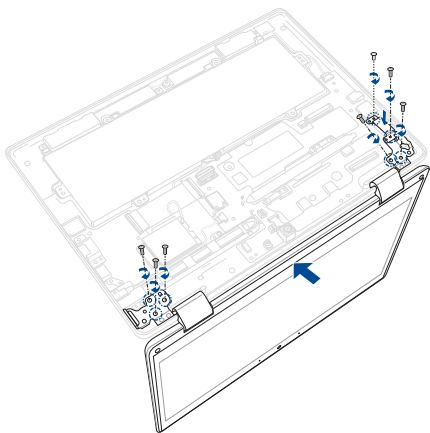

LCD module screw map

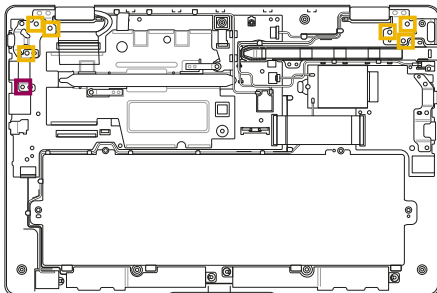

■ M2.5 X 4.5L (6PCS)

■ M2.0 X 3.0L (1PC)

U. Reconnect all the cable(s) as shown in the illustration below.

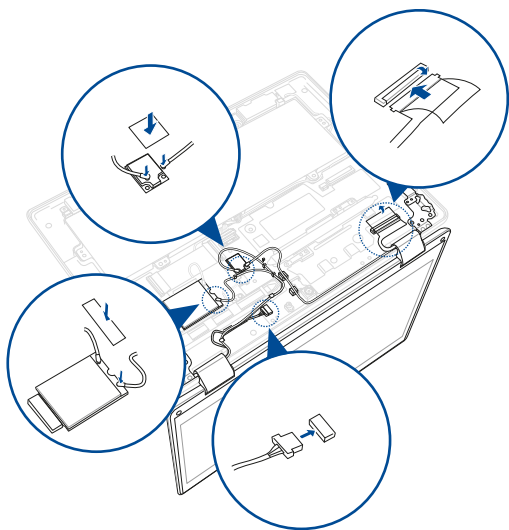

Replacing the LCD module (Clamshell model)

IMPORTANT! Do not bend the LCD panel module in any ways to avoid risk of LCD panel leakage.

NOTE: The illustrations are for reference only.

- A. Remove the compartment cover and disconnect the battery.
-

NOTE: For more details, refer to the *Removing the compartment cover* and *Disconnecting the battery* sections in this manual.

- B. Locate and disconnect all the cable(s) as shown in the illustration below.

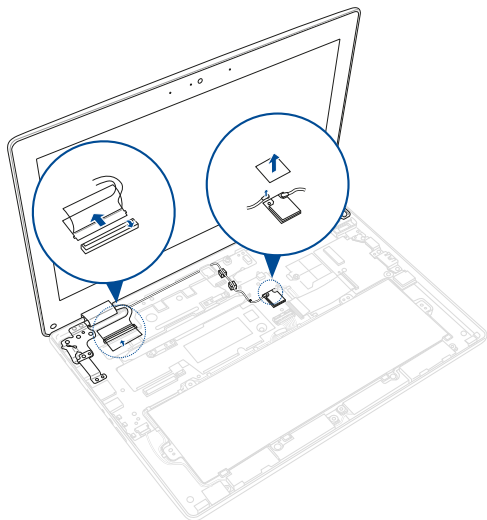

- C. Remove the screw(s) from the hinges and I/O bracket, and then remove the LCD panel module.

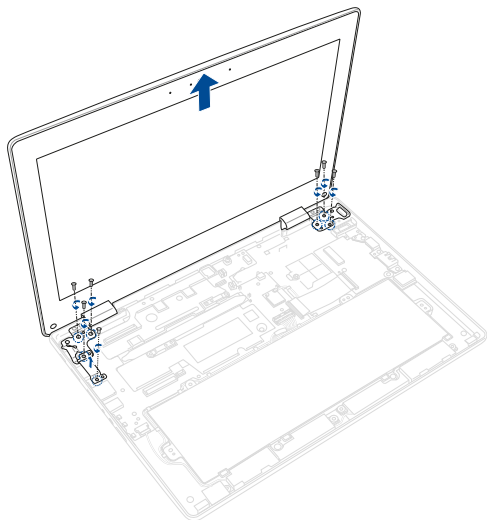

- D. Flatten the LCD hinges.

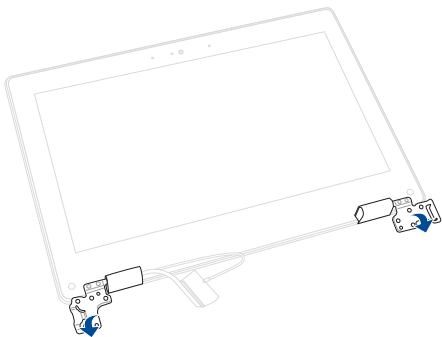

- E. Use the tweezers to remove the screw cap cover(s) from the screw(s) as shown in the illustration below.

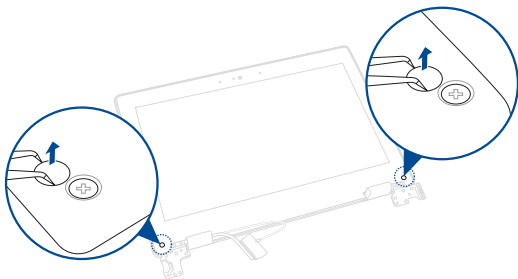

- F. Remove the screw(s) from the LCD bezel.

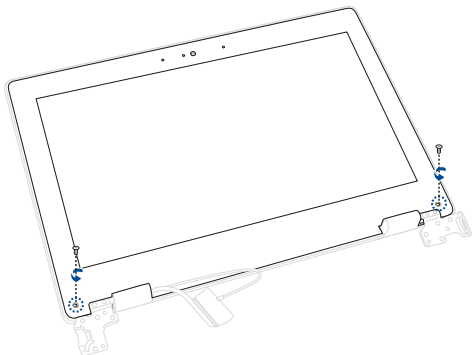

- G. Pry loose the bottom side of the LCD bezel first, then continue with the left, right, and top sides of the bezel. **DO NOT** remove the LCD bezel!

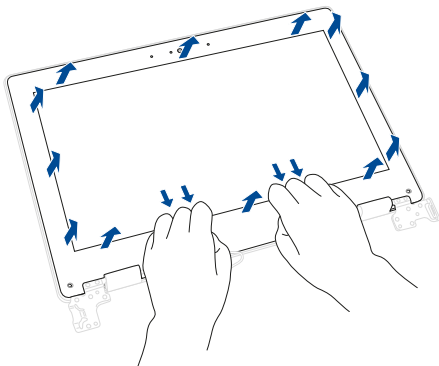

- H. Release the eDP cable from the LCD hinge cap. Then remove the LCD bezel.

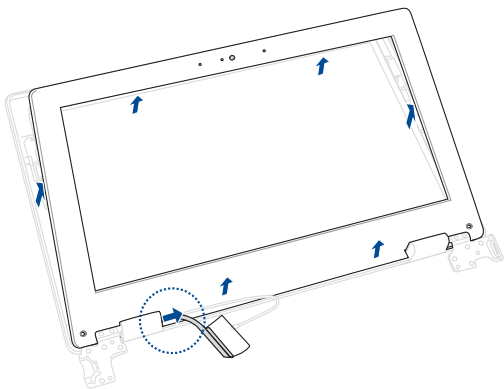

- I. Remove the screw(s) from the LCD panel.

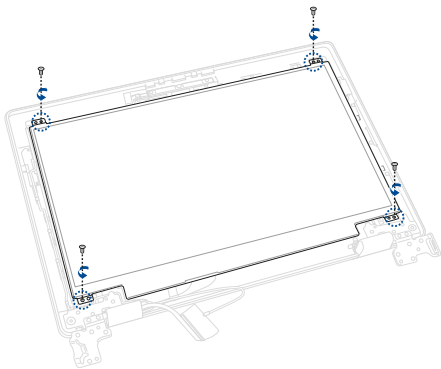

- J. Locate and disconnect the eDP cable(s) as shown in the illustration below.
- K. Remove the LCD panel.

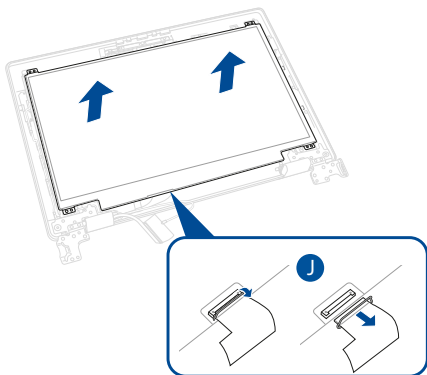

- L. Prepare the new LCD panel.
- M. Reconnect the eDP cable(s) as shown in the illustration below.
- N. Align and place the new LCD panel in the orientation as shown in the illustration below.

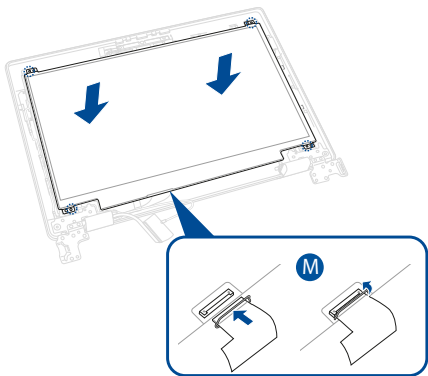

- O. Secure the LCD panel using the screw(s) you removed earlier.

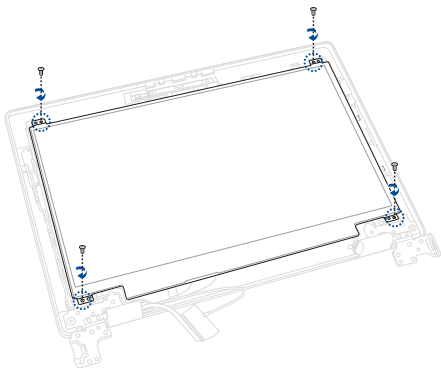

- P. Replace a portion of the eDP cable to the LCD hinge cap. Then gently reattach the LCD bezel around the LCD panel.

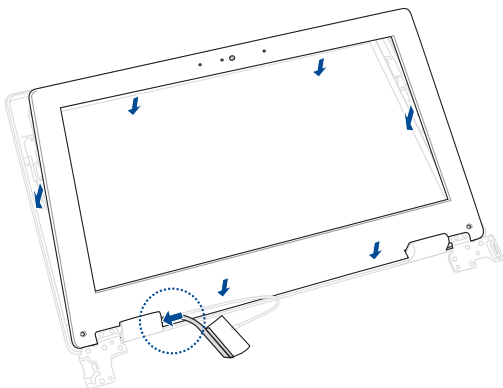

- Q. Secure the LCD bezel using the screw(s) you removed earlier.

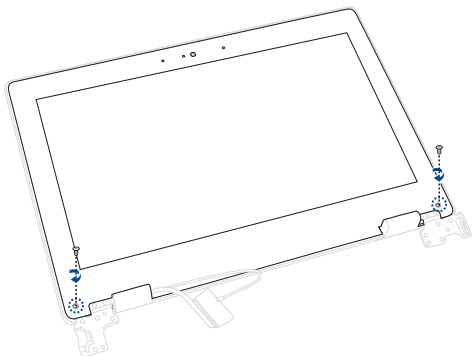

- R. Use the tweezers to replace the screw cap cover(s) as shown in the illustration below.

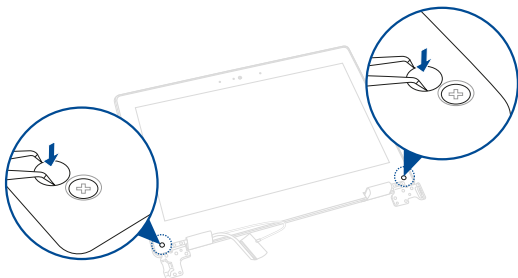

- S. Fold the LCD hinges until 90 degrees.

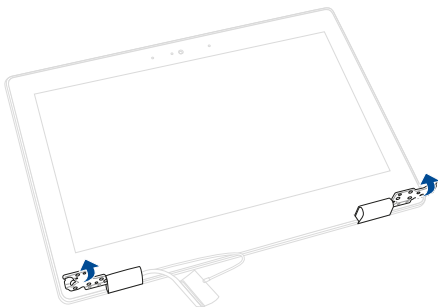

- T. In the orientation shown, align and place the hinges of the display module and I/O bracket on the screw holes on the chassis.
- U. Secure the LCD panel module using the screw(s) you removed earlier.

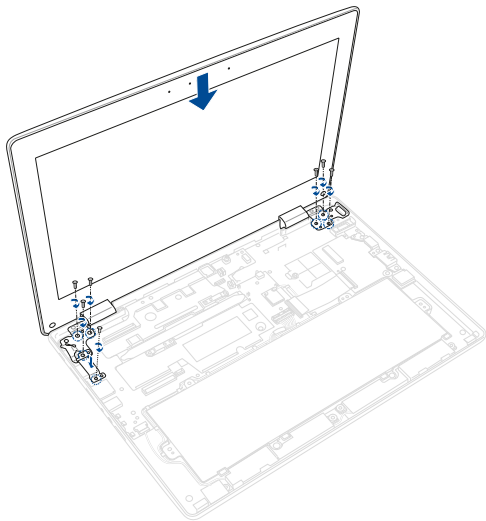

LCD module screw map

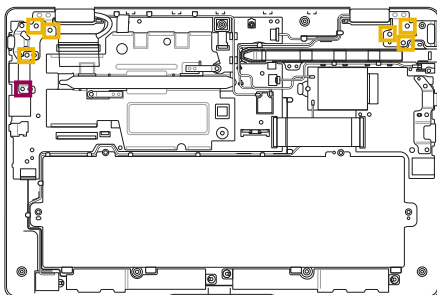

■ M2.5 X 4.5L (6PCS)

■ M2.0 X 3.0L (1PC)

- V. Reconnect all the cable(s) as shown in the illustration below.

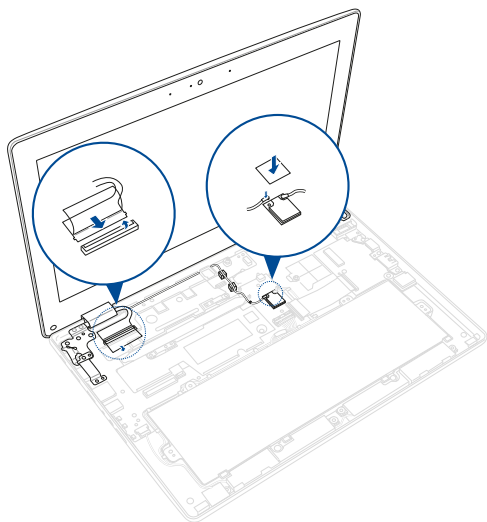

Wiring and connection diagrams

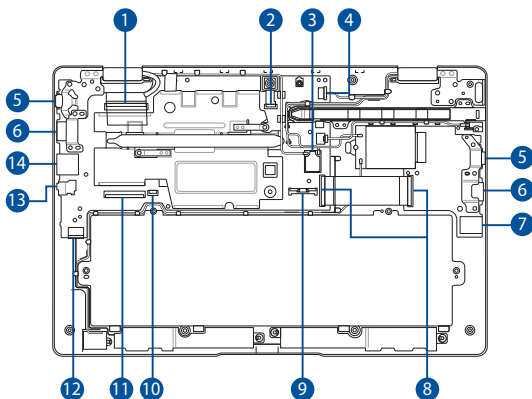

Top View

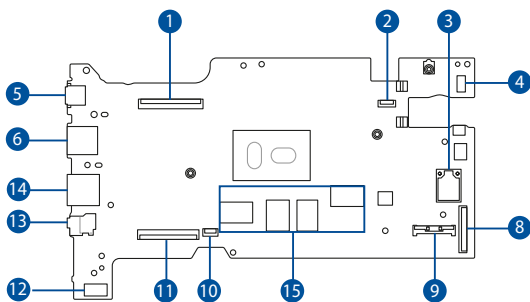

Bottom View

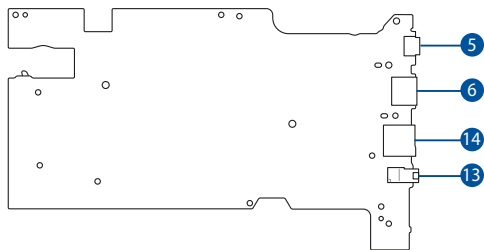

- | | |
|--------------------------|---|
| 1. eDP/Camera connector | 9. Battery power connector |
| 2. MIPI connector | 10. Touchpad connector |
| 3. WiFi module | 11. Keyboard connector |
| 4. P sensor connector | 12. Speaker connector |
| 5. USB Type-C® connector | 13. Headphone/Headset/
Microphone jack |
| 6. USB Type-A connector | 14. MicroSD card connector |
| 7. SIM card connector | 15. Random-access memory (RAM)
module |
| 8. I/O FPC connector | |