

E10189
First Edition
February 2015

Mini Desktop PC

User Guide

E510 Series

ASUS[®]
IN SEARCH OF INCREDIBLE

COPYRIGHT INFORMATION

No part of this manual, including the products and software described in it, may be reproduced, transmitted, transcribed, stored in a retrieval system, or translated into any language in any form or by any means, except documentation kept by the purchaser for backup purposes, without the express written permission of ASUSTeK COMPUTER INC. ("ASUS").

ASUS PROVIDES THIS MANUAL "AS IS" WITHOUT WARRANTY OF ANY KIND, EITHER EXPRESS OR IMPLIED, INCLUDING BUT NOT LIMITED TO THE IMPLIED WARRANTIES OR CONDITIONS OF MERCHANTABILITY OR FITNESS FOR A PARTICULAR PURPOSE. IN NO EVENT SHALL ASUS, ITS DIRECTORS, OFFICERS, EMPLOYEES OR AGENTS BE LIABLE FOR ANY INDIRECT, SPECIAL, INCIDENTAL, OR CONSEQUENTIAL DAMAGES (INCLUDING DAMAGES FOR LOSS OF PROFITS, LOSS OF BUSINESS, LOSS OF USE OR DATA, INTERRUPTION OF BUSINESS AND THE LIKE), EVEN IF ASUS HAS BEEN ADVISED OF THE POSSIBILITY OF SUCH DAMAGES ARISING FROM ANY DEFECT OR ERROR IN THIS MANUAL OR PRODUCT.

Products and corporate names appearing in this manual may or may not be registered trademarks or copyrights of their respective companies, and are used only for identification or explanation and to the owners' benefit, without intent to infringe.

SPECIFICATIONS AND INFORMATION CONTAINED IN THIS MANUAL ARE FURNISHED FOR INFORMATIONAL USE ONLY, AND ARE SUBJECT TO CHANGE AT ANY TIME WITHOUT NOTICE, AND SHOULD NOT BE CONSTRUED AS A COMMITMENT BY ASUS. ASUS ASSUMES NO RESPONSIBILITY OR LIABILITY FOR ANY ERRORS OR INACCURACIES THAT MAY APPEAR IN THIS MANUAL, INCLUDING THE PRODUCTS AND SOFTWARE DESCRIBED IN IT.

Copyright © 2015 ASUSTeK COMPUTER INC. All Rights Reserved.

LIMITATION OF LIABILITY

Circumstances may arise where because of a default on ASUS' part or other liability, you are entitled to recover damages from ASUS. In each such instance, regardless of the basis on which you are entitled to claim damages from ASUS, ASUS is liable for no more than damages for bodily injury (including death) and damage to real property and tangible personal property; or any other actual and direct damages resulted from omission or failure of performing legal duties under this Warranty Statement, up to the listed contract price of each product.

ASUS will only be responsible for or indemnify you for loss, damages or claims based in contract, tort or infringement under this Warranty Statement.

This limit also applies to ASUS' suppliers and its reseller. It is the maximum for which ASUS, its suppliers, and your reseller are collectively responsible.

UNDER NO CIRCUMSTANCES IS ASUS LIABLE FOR ANY OF THE FOLLOWING: (1) THIRD-PARTY CLAIMS AGAINST YOU FOR DAMAGES; (2) LOSS OF, OR DAMAGE TO, YOUR RECORDS OR DATA; OR (3) SPECIAL, INCIDENTAL, OR INDIRECT DAMAGES OR FOR ANY ECONOMIC CONSEQUENTIAL DAMAGES (INCLUDING LOST PROFITS OR SAVINGS), EVEN IF ASUS, ITS SUPPLIERS OR YOUR RESELLER IS INFORMED OF THEIR POSSIBILITY.

SERVICE AND SUPPORT

Visit our multi-language web site at <http://support.asus.com>

Table of Contents

About this user guide	7
Conventions used in this user guide	9
Typography	9
Icons	9
Safety precautions	10
Using your Mini Desktop PC	10
Servicing and replacement of parts	10
Caring for your Mini Desktop PC	11
Proper disposal	11
Package contents	12
Chapter 1: Mini Desktop PC parts and features	
Getting to know your Mini Desktop PC	14
Main box	15
Front features	15
Rear features	17
Side features	19
Bottom features	21
Docking (optional)	22
Front features	22
Rear features	23
Top features	24
Bottom features	25
Chapter 2: Hardware setup	
Connecting the optional docking to the main box	28
Setting up your Mini Desktop PC	30
Powering on	36
Using a VESA mount (optional)	37
Chapter 3: Using your Mini Desktop PC	
Proper posture when using your Mini Desktop PC	42
Tips on using your Mini Desktop PC	43

Using the optical drive	44
Inserting an optical disc	44
Manual eject hole	46

Chapter 4: Supported operating systems

Working with Windows® 7	48
Starting for the first time	48
Using the Start menu	49
Using the taskbar	50
Using the notification area	51
Using Windows® Explorer	52
Backing up files	54
Restoring your system settings	54
Using Windows® 7 Action Center	55
Using Windows® Update	55
Setting up a user account and password	56
Using Windows® Help and Support	56
Microsoft's Windows® 8.1 Downgrade Notices	57
Changing your operating system to Windows® 8.1	58
Working with Windows® 8.1	60
Starting for the first time	60
Windows® UI	61
Start button	65
Customizing your Start screen	67
Working with Windows® apps	68
Customizing apps	68
Accessing the Apps screen	70
Charms bar	72
Snap feature	74
Other keyboard shortcuts	76
Connecting to the Internet	78
Turning your Mini Desktop PC off	82
Putting your Mini Desktop PC on sleep mode	82
Windows® 8.1 lock screen	83
Customizing your lock screen	84

Chapter 5: ASUS Business Manager

ASUS Business Manager	88
Installing ASUS Business Manager	88
Starting ASUS Manager	90
System	91
Update	92
Security	93
USB Lock	97
Backup & Recovery.....	97
Power	98
Tool	99
Intel® SBA (Small Business Advantage)	102

Chapter 6: BIOS Setup

Knowing BIOS.....	106
Entering BIOS	106
BIOS menu options.....	107
Main	107
Advanced.....	108
Boot	109
Tool	110
ASUS EZ Flash 2 Utility.....	111
Configuring HDD access.....	112
Configuring USB ports.....	115

Troubleshooting

Power	122
Display	123
LAN	124
Audio	125
System	126
CPU	127

Appendix

ASUS Recycling/Takeback Services	130
REACH.....	130
Declaration of Conformity (R&TTE directive 1999/5/EC).....	130
Wireless Operation Channel for Different Domains.....	131
CE Mark Warning.....	131
CE marking for devices without wireless LAN/Bluetooth.....	131
CE marking for devices with wireless LAN/ Bluetooth.....	131
Federal Communications Commission Statement	132
Lithium Battery Warning	133
RF Exposure Warning	133
IC: Canadian Compliance Statement.....	134
Canadian Department of Communications Statement	134
VCCI: Japan Compliance Statement	135
VCCI Class B Statement.....	135
KC: Korea Warning Statement.....	135
RF Equipment Notices.....	135
CE: European Community Compliance Statement	135
Wireless Radio Use	135
Exposure to Radio Frequency Energy	135
FCC Bluetooth Wireless Compliance.....	136
Bluetooth Industry Canada Statement.....	136
BSMI: Taiwan Wireless Statement	136
Japan RF Equipment Statement.....	136
KC (RF equipment)	136
Optical Drive Safety Information	137
Laser Safety Information.....	137
Service warning label.....	137
CDRH Regulations	137
ENERGY STAR complied product	138
ASUS Contact Information.....	139
ASUSTeK COMPUTER INC.....	139
ASUS COMPUTER INTERNATIONAL (America).....	139
ASUS COMPUTER GmbH (Germany and Austria).....	140

About this user guide

This user guide provides information about the hardware and software features of your PC, organized through the following chapters:

Chapter 1: Mini Desktop PC parts and features

This chapter details the hardware components of your Mini Desktop PC.

Chapter 2: Hardware setup

This chapter provides you with information on how to prepare and setup your Mini Desktop PC for usage.

Chapter 3: Using your Mini Desktop PC

This chapter provides you with information on using your Mini Desktop PC.

Chapter 4: Supported operating systems

This chapter provides an overview of using operating systems in your Mini Desktop PC.

Chapter 5: ASUS Business Manager

This chapter provides an overview of using ASUS Business Manager in your Mini Desktop PC.

Chapter 6: BIOS Setup

This chapter provides information on how to change the system settings through the BIOS Setup menus.

Troubleshooting

This section presents some recommended tips, hardware FAQs, and software FAQs you can refer to for maintaining and fixing common issues with your Mini Desktop PC.

Appendices

This section includes notices and safety statements your Mini Desktop PC.

Conventions used in this user guide

To highlight key information in this user guide, some text are presented as follows:

IMPORTANT! This message contains vital information that must be followed to complete a task.

NOTE: This message contains additional information and tips that can help complete tasks.

WARNING! This message contains important information that must be followed to keep you safe while performing tasks and prevent damage to your Mini Desktop PC's data and components.

Typography

- Bold** = This indicates a menu or an item that must be selected.
- Italic* = This indicates sections that you can refer to in this user guide.

Icons

The icons below indicate the devices you can use for completing a series of tasks or procedures while working on the Windows® 8.1 operating system of your Mini Desktop PC.



= Use a mouse.



= Use a keyboard.

Safety precautions

Using your Mini Desktop PC

- Refer to the user guide and take note of the safety instructions before operating your Mini Desktop PC.
- Follow the notes and warnings stated in the user guide.
- Do not place your Mini Desktop PC on uneven or unstable surfaces.
- Do not use your Mini Desktop PC in smoky environments. Smoke residue may cause build-up on critical parts and damage the Mini Desktop PC or decrease its performance.
- Do not use damaged power cords, accessories, and other peripherals with your Mini Desktop PC.
- Keep the Mini Desktop PC's plastic packages out of the reach of children.
- Do not block or place anything near the Mini Desktop PC's ventilation holes. Doing so may cause internal heat build-up.
- Ensure that the operating voltage of your Mini Desktop PC matches the voltage of your power source.

Servicing and replacement of parts

- Do not disassemble or attempt to service this Mini Desktop PC by yourself. Contact your local ASUS service center for assistance.
- When replacing parts of your Mini Desktop PC, purchase items as specified by ASUS and contact your local service center for assistance.

Caring for your Mini Desktop PC

- Switch off then unplug the Mini Desktop PC from the power outlet before cleaning it.
- When cleaning the Mini Desktop PC's housing, use a clean soft cloth dampened with water or a mix of water and neutral detergent. Wipe it dry using a soft dry cloth.
- Do not use liquid or aerosole cleaners, benzene, or thinners on your Mini Desktop PC.

Proper disposal



Do not throw your Mini Desktop PC in municipal waste. This product has been designed to enable proper reuse of parts and recycling. The symbol of the crossed out wheeled bin indicates that the product (electrical, electronic equipment and mercury-containing button cell battery) should not be placed in municipal waste. Check local regulations for disposal of electronic products.



Do not throw the battery in municipal waste. The symbol of the crossed out wheeled bin indicates that the battery should not be placed in municipal waste.

Package contents

Your Mini Desktop PC package contains the following items:



Mini Desktop PC E510 Series main box



Mini Desktop PC E510 Series docking (optional)

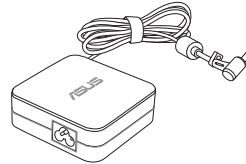

AC power adapter

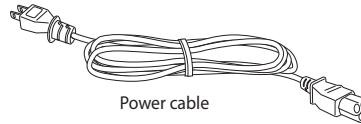

Power cable

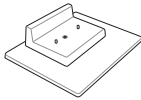

stand



antenna



USB bridge (optional)



4 pcs. 8mm screws for VESA mounting plate

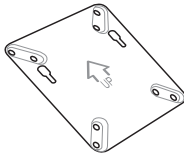

VESA mounting plate

4 pcs. rubber heads for VESA mounting plate



2 pcs. 12mm screws

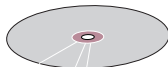

Driver DVD*



Technical documentations

NOTES:

- *Actual product specifications and package contents may vary with your Mini Desktop PC's model type or with country or region.
- If the device or its components fail or malfunction during normal and proper use within the warranty period, bring the warranty card to the ASUS Service Center for replacement of the defective components.

1

Mini Desktop PC parts and features

Getting to know your Mini Desktop PC

Your Mini Desktop PC is made up of these devices: a main box and an optional docking.

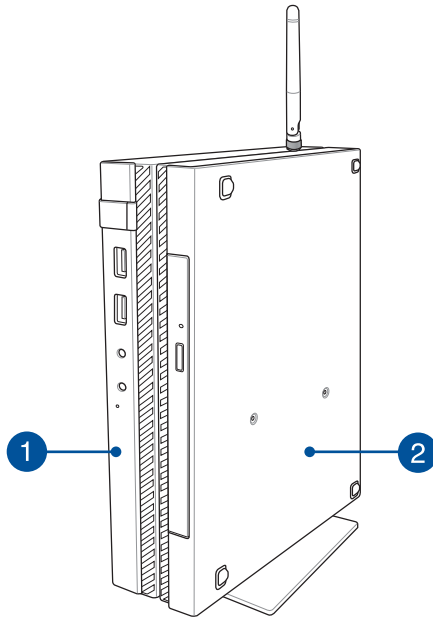

1 Main box

The main box contains the operating system and main hardware peripherals of your Mini Desktop PC. It also includes a set of I/O ports that connects your Mini Desktop PC to external devices.

2 Docking (optional)

The docking is an optional accessory to your Mini Desktop PC. It contains an optical disc drive and additional I/O ports for external device connectivity.

Main box

Front features

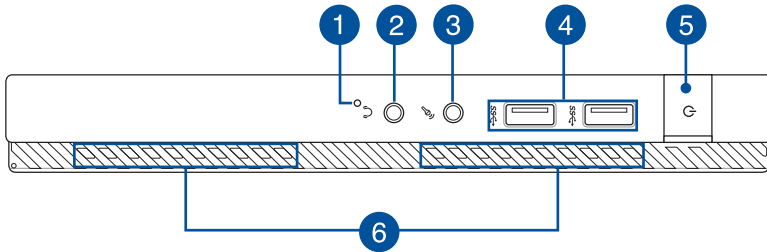

1 BIOS key

Before booting up the system, insert a straightened paper clip into this hole to enter BIOS.

NOTE: For details about using BIOS, refer to the *Chapter 6: Basic Input and Output System (BIOS)* section in this user guide.

2 Audio output jack port

The audio output jack port allows you to connect your Mini Desktop PC to amplified speakers or headphones.

3 Microphone input jack port

The microphone input jack port allows you to connect your Mini Desktop PC to an external microphone.

4 USB 3.0 ports

These USB (Universal Serial Bus) 3.0 ports provide a transfer rate of up to 5 Gbit/s and are backward compatible to USB 2.0.

5 **Power button**

Press the power button to turn your Mini Desktop PC on or off. You can also use the power button to put your Mini Desktop PC to sleep or hibernate mode and wake it up from sleep or hibernate mode.

In the event that your Mini Desktop PC becomes unresponsive, press and hold the power button for about four (4) seconds until your Mini Desktop PC shuts down.

6 **Air vents**

The air vents allow cool air to enter and warm air to exit the Mini Desktop PC.

WARNING! Ensure that paper, books, clothing, cables, or other objects do not block any of the air vents or else overheating may occur.

Rear features

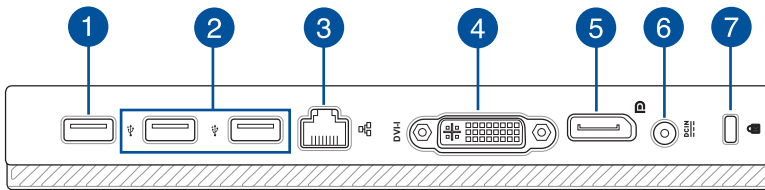

1 USB 2.0 port

The USB 2.0 (Universal Serial Bus 2.0) port is compatible with USB 2.0 or USB 1.1 devices.

USB 2.0 port for the USB bridge*

This USB 2.0 port is exclusive for use with the USB bridge. Insert the USB bridge into this port to connect the main box with the docking of your Mini Desktop PC.

NOTE: For more details about using this exclusively with the USB bridge, refer to the *Setting up your Mini Desktop PC* section in this user guide.

2 USB 2.0 ports

The USB 2.0 (Universal Serial Bus 2.0) port is compatible with USB 2.0 or USB 1.1 devices.

3 LAN port

Insert the network cable into this port to connect to a local area network.

** on selected models only*

4 **DVI-I port**

The DVI-I port is HDCP compliant and allows you to connect your Mini Desktop PC to any DVI-I compatible device.

5 **DisplayPort port**

Use this port to connect your Mini Desktop PC to a DisplayPort, VGA, DVI, or HDMI external display.

6 **Power (DC) input port**

Insert the bundled power adapter into this port to charge the battery pack and supply power to your Mini Desktop PC.

WARNING! The adapter may become warm to hot while in use. Do not cover the adapter and keep it away from your body while it is connected to a power source.

IMPORTANT! Use only the bundled power adapter to charge the battery pack and supply power to your Mini Desktop PC.

7 **Kensington® security slot**

The Kensington® security slot allows you to secure your Mini Desktop PC using Kensington® compatible Mini Desktop PC security products.

Side features

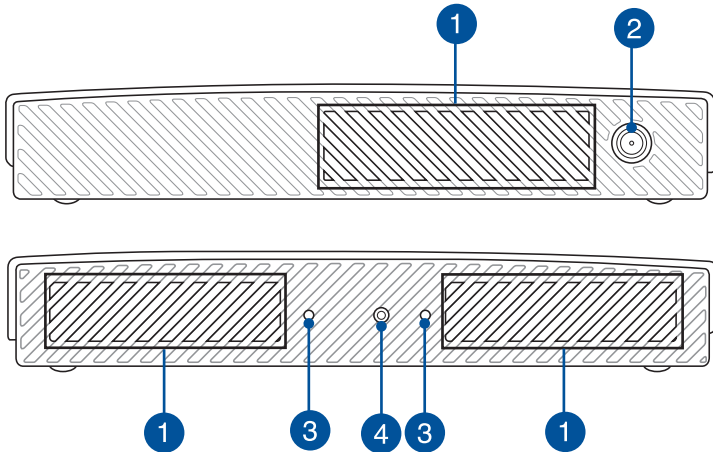

1 Air vents

The air vents allow cool air to enter and warm air to exit the Mini Desktop PC.

WARNING! Ensure that paper, books, clothing, cables, or other objects do not block any of the air vents or else overheating may occur.

2 Antenna connector

This connector is used to connect the bundled antenna to your Mini Desktop PC.

3 Guide slots for the Mini Desktop PC stand

These slots allow you to properly orient your Mini Desktop PC when connecting it with the bundled stand. It also provides additional support to ensure that your device is held securely in place.

4 Screw hole for the Mini Desktop PC stand

This screw hole allows you to attach and secure your Mini Desktop PC with its bundled stand.

Bottom features

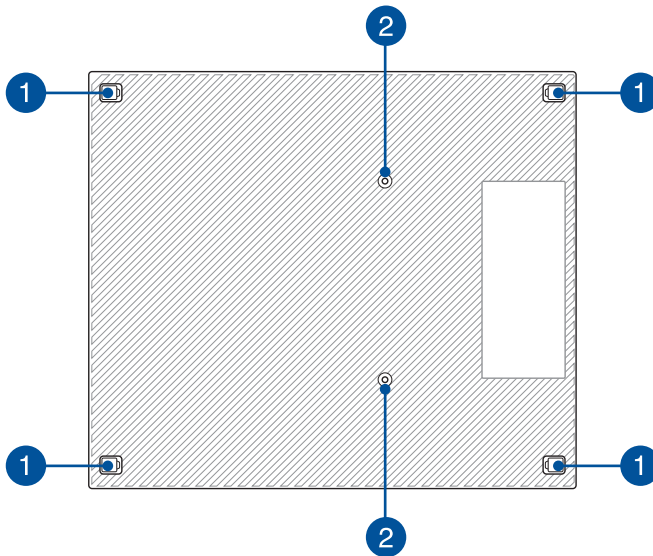

1 Removable rubber feet

These removable rubber feet has two functions: it protects your Mini Desktop PC while laid on a flat surface with the bottom side down and also covers the chassis screws of your Mini Desktop PC.

2 Screw holes for the optional docking

This screw hole allows you to connect and secure your Mini Desktop PC with its optional docking.

Docking (optional)

Front features

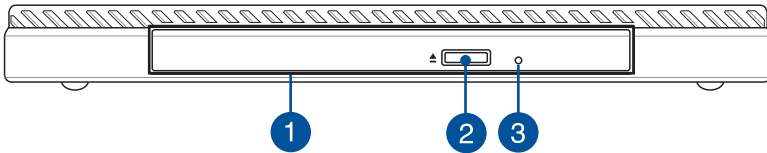

- 1 Optical drive**

Your docking's optical drive may support several disc formats such as CDs, DVDs, recordable discs, or rewritable discs.
- 2 Optical disc drive eject button**

Press this button to eject the optical drive tray.
- 3 Optical disc drive manual eject hole**

The manual eject hole is used to eject the drive tray in case the electronic eject button does not work.

WARNING! Use the manual eject hole only when the electronic eject button does not work.

Rear features

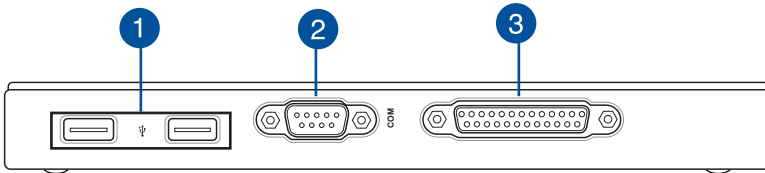

- 1 USB 2.0 ports**

The USB 2.0 (Universal Serial Bus 2.0) port is compatible with USB 2.0 or USB 1.1 devices.
- 2 COM port**

This COM port is for pointing devices or other serial devices
- 3 Parallel port**

This parallel port allows you to connect your Mini Desktop PC to external devices that uses parallel port connectors, such as printers and scanners.

Top features

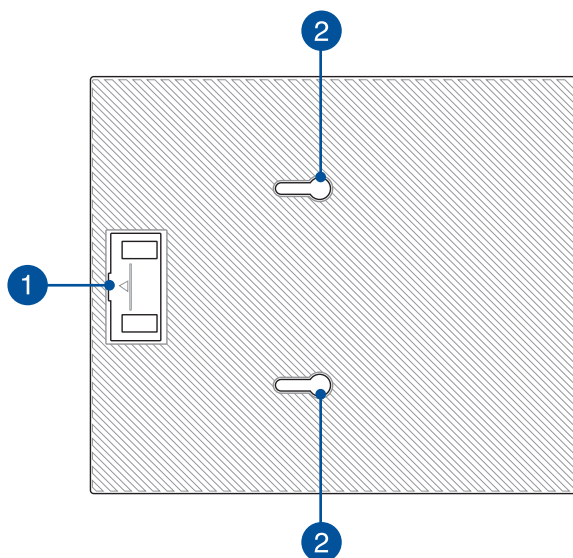

1 USB bridge compartment

This compartment contains the bundled USB bridge that allows you to connect the docking with the main box of your Mini Desktop PC.

NOTE: For more details, refer to the *Connecting the optional docking to the main box* section in this user guide.

2 Main box latches

These latches allow you to securely attach the main box to the docking.

Bottom features

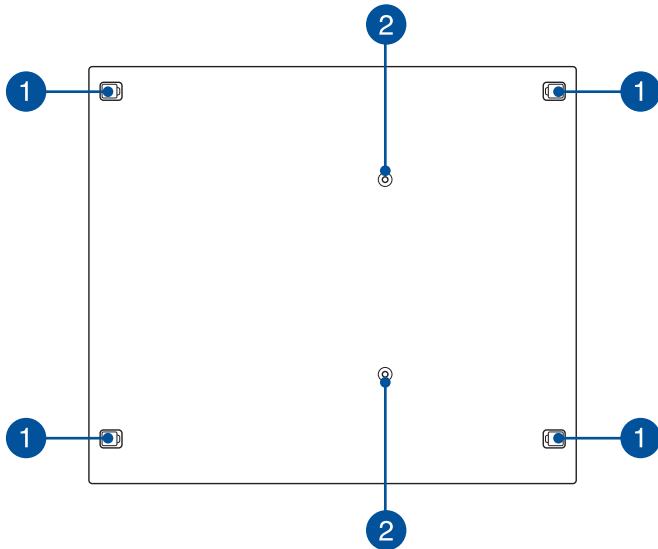

1 Removable rubber feet

These removable rubber feet has two functions: it protects your Mini Desktop PC while laid on a flat surface with the bottom side down and also covers the chassis screws of your docking.

2 Screw holes for the VESA mount

These screw holes allows you to connect and secure your Mini Desktop PC to a VESA mount.

2

Hardware setup

Connecting the optional docking to the main box

If you purchased the optional docking together with the main box, refer to the following steps to know how to setup these parts of your Mini Desktop PC.

- A. Attach two bundled screws on the bottom side of the main box.

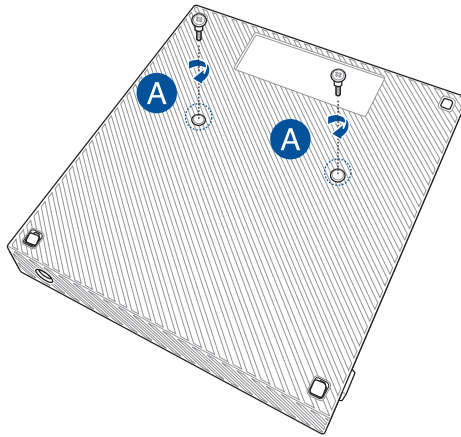

- B. Detach the USB bridge from the USB bridge compartment.

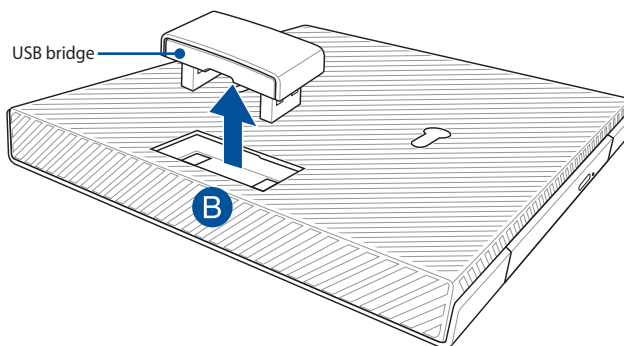

- C. Align and insert the screws on the bottom side of the main box into the main box latches on the docking.
- D. Gently push the main box to the left to completely attach it with the docking.

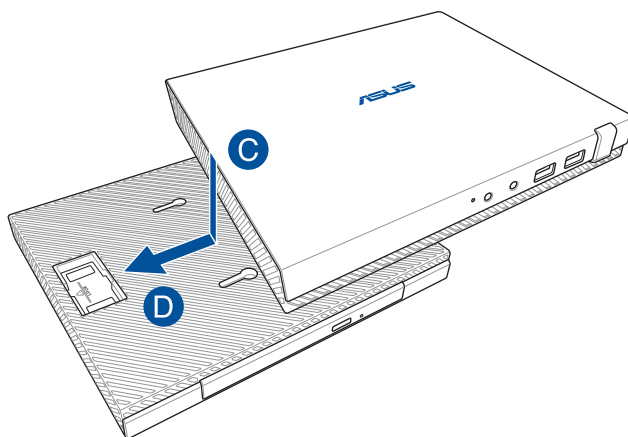

- E. Attach the USB bridge into its designated USB 2.0 ports on the main box and the docking.

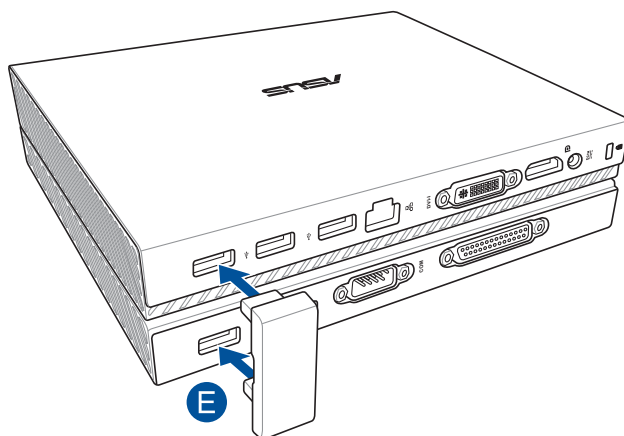

Setting up your Mini Desktop PC

Setup your Mini Desktop PC using the following steps and illustrations. This section also includes information on how to connect your Mini Desktop PC with external devices and its bundled power adapter.

IMPORTANT! The docking of your Mini Desktop PC is an optional item. Consult your local retailer if you want to purchase it for your main box.

NOTE: The following illustrations are for reference only.

- A. Connect the bundled antenna into the main box.
- B. Align then attach the stand onto your main box.
- C. Fasten the bundled screw on the stand to secure the Mini Desktop PC in place.

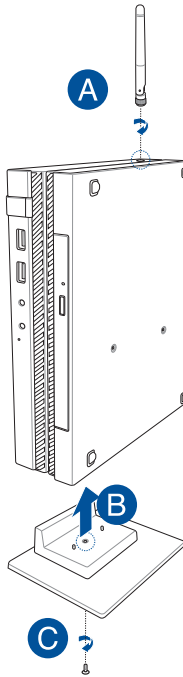

D. Connect a display panel or projector to your Mini Desktop PC that has the following connectors:

- DisplayPort connector
- COM connector
- DVI-I connector

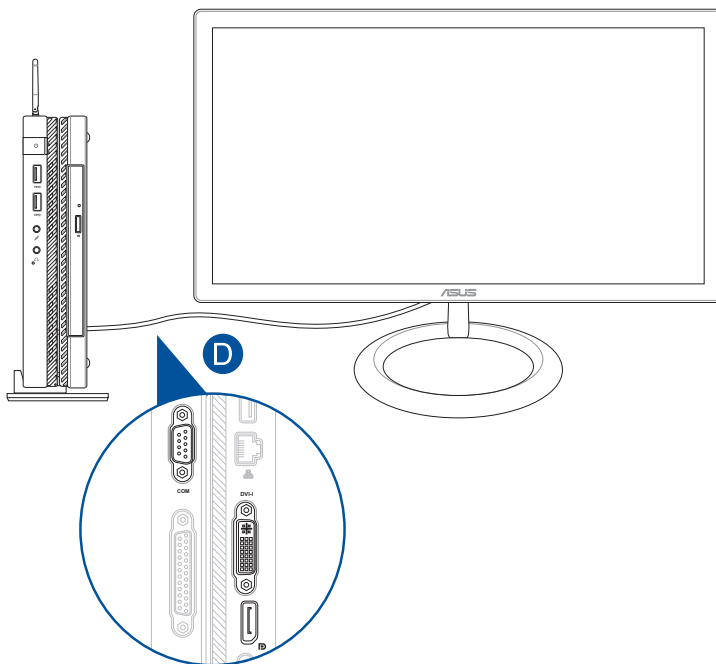

- E. Connect the keyboard and mouse to your Mini Desktop PC. You can also connect a USB dongle for a wireless keyboard and mouse set.

NOTE: Refer to your wireless keyboard and wireless mouse user guide for installation details.

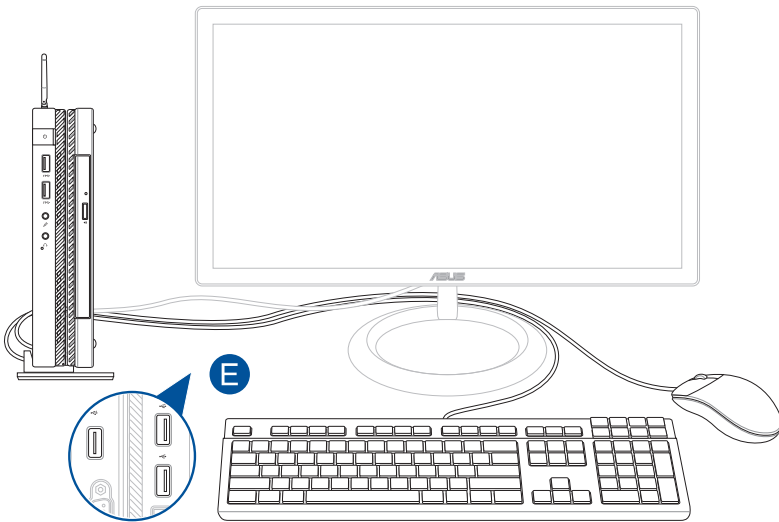

- F. Connect the AC power cord to the AC/DC adapter.
- G. Plug the AC power adapter into a 100V~240V power source.
- H. Connect the DC power connector into your Mini Desktop PC's power (DC) input.

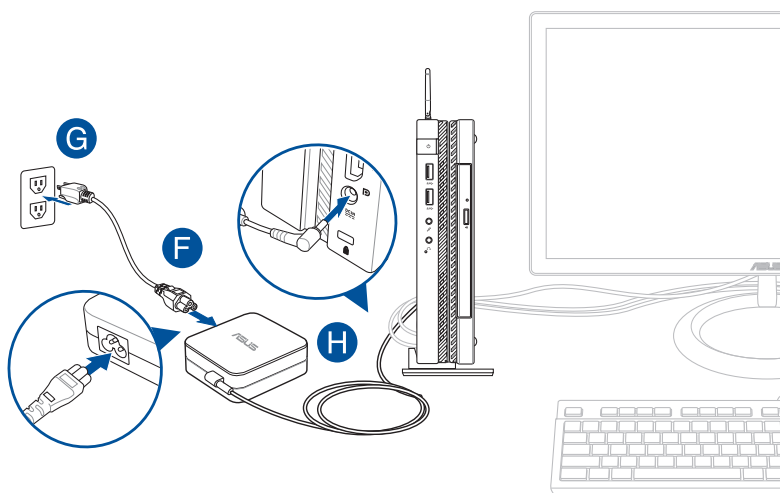

IMPORTANT!

- We strongly recommend that you use only the AC power adapter and cable that came with your Mini Desktop PC.
 - We strongly recommend that you use a grounded wall socket while using your Mini Desktop PC. The socket outlet must be easily accessible and near your Mini Desktop PC.
 - To disconnect your Mini Desktop PC from its main power supply, unplug your Mini Desktop PC from the power socket.
-

NOTE:

Power adapter information:

- Input voltage: 100-240Vac
 - Input frequency: 50-60Hz
 - Rating output current: 3.42A (65W)
 - Rating output voltage: 19V
-

AC power cord requirements

Use the correct AC plug type according to your current location.

IMPORTANT! Contact your sales dealer if the AC power cord bundled with your Mini Desktop PC does not match your local power source.

NOTE: We highly recommend that you use a video source device that also uses a grounding type plug to prevent signal interference due to voltage fluctuations.

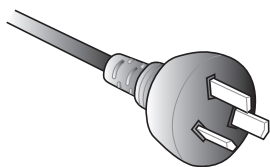

for Australia and Mainland China

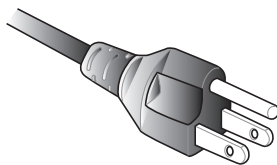

for U.S.A., Canada, and Taiwan

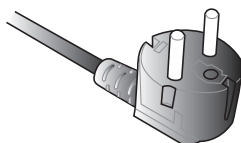

for Continental Europe

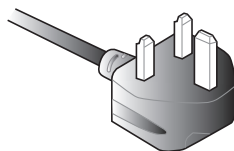

for U.K.

Powering on

Press the power button to turn on your Mini Desktop PC.

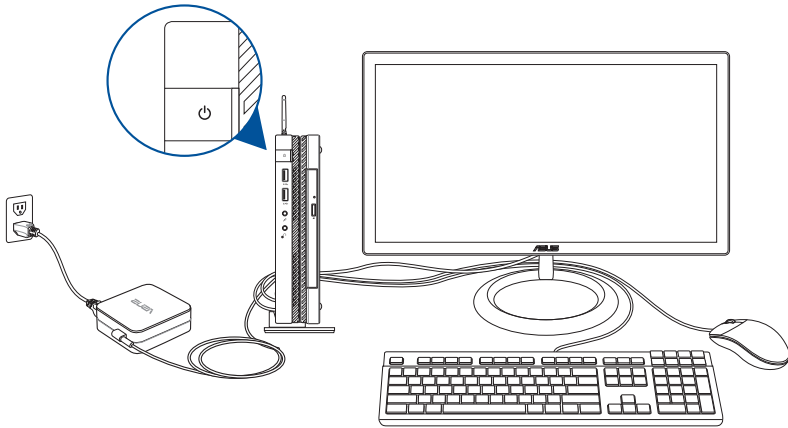

Using a VESA mount (optional)

Your Mini Desktop PC package has a bundled VESA mounting plate that allows you to install your Mini Desktop PC to a VESA mount-compatible device.

To install your Mini Desktop PC to a VESA mount-compatible device:

1. Place your Mini Desktop PC upside down on a flat and stable surface.
2. Attach the two bundled screws into the screw holes at the bottom side of the docking.

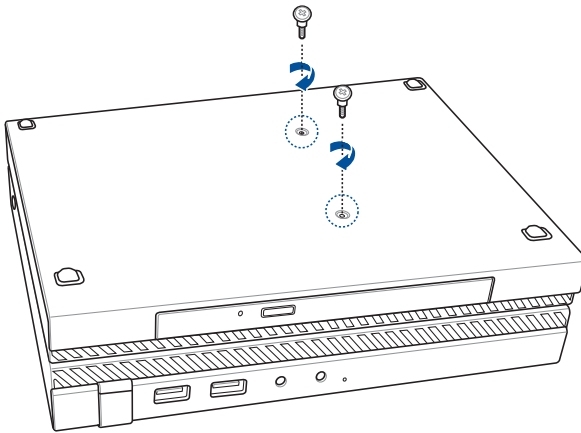

WARNING! Do not overtighten the screws as it may cause damage to your Mini Desktop PC.

3. Match and insert the four (4) 8mm screws into the four (4) rubber washers.



4. Remove the screw hole covers at the back of your VESA mount-compatible device, if any.
5. With the arrow on the VESA mounting plate pointing upward, align its screw holes to the screw holes of the VESA mount-compatible device.
6. Secure the VESA mounting plate to the VESA mount-compatible device using the screws with the rubber washers.

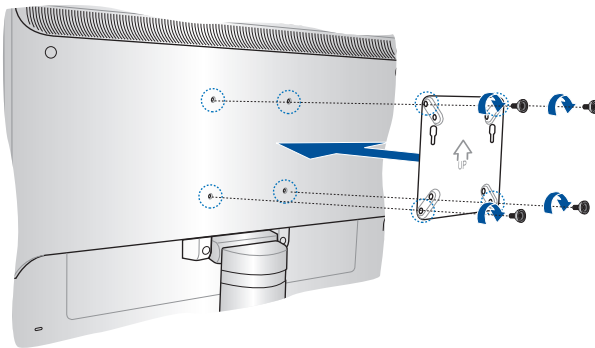

NOTE: Your Mini Desktop PC can be mounted on an ASUS VS228H monitor.

WARNING! Do not overtighten the screws as it may cause damage to your VESA mount-compatible device.

7. Insert the two screws attached on the Mini Desktop PC to the mounting holes of the VESA mounting plate, then gently push the Mini Desktop PC down to secure it in place.

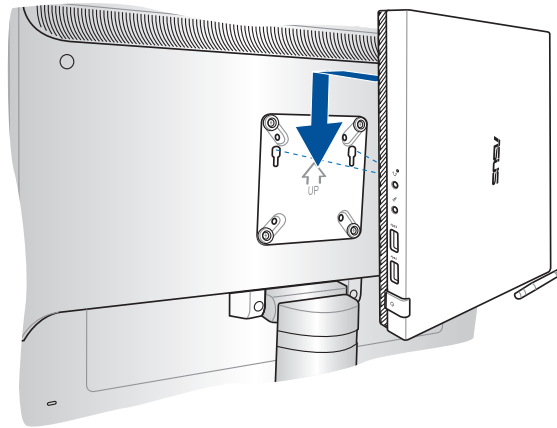

3

Using your Mini Desktop PC

Proper posture when using your Mini Desktop PC

When using your Mini Desktop PC, maintaining proper posture is necessary to prevent straining your wrists, hands, certain joints and muscles.

This section provides tips on how to avoid physical discomfort and possible injury while using your Mini Desktop PC.



Tips on using your Mini Desktop PC

- Position your computer chair in such a way that the elbows are at or slightly above the keyboard for a more comfortable typing position.
- Adjust the height of your chair to ensure that your knees are slightly higher than your hips to relax the back of your thighs. If possible, use a footrest to raise the level of your knees.
- Adjust the back of your chair so that the base of your spine is firmly supported and angled slightly backward.
- Sit upright with your knees, elbows, and hips at an approximately 90° angle.
- Place the monitor directly in front of you and position the top side of its screen at eye level so that your eyes look slightly downward.
- Keep the mouse close to the keyboard. If possible, use a wrist rest for support to help reduce pressure on your wrists while typing.
- Use your Mini Desktop PC in a comfortably-lit area and keep it away from sources of glaring light such as windows and direct sunlight.
- Take regular mini-breaks while using your Mini Desktop PC.

Using the optical drive

Inserting an optical disc

- A. While the Mini Desktop PC is on, press the electronic eject button to partially eject the optical drive tray.

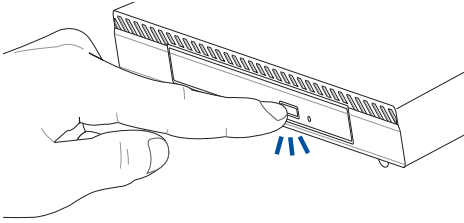

- B. Gently pull out the drive tray.

IMPORTANT! Be careful not to touch the optical drive lens. Ensure that there are no objects that may get jammed under the drive tray.

- C. Hold the disc by the edge, with its printed side up, then gently place it inside the hub.

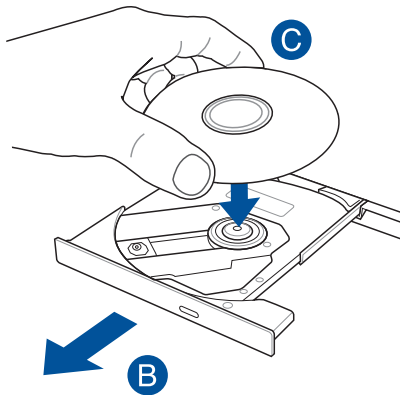

- D. Push down the disc's plastic hub until it snaps onto the optical drive hub.

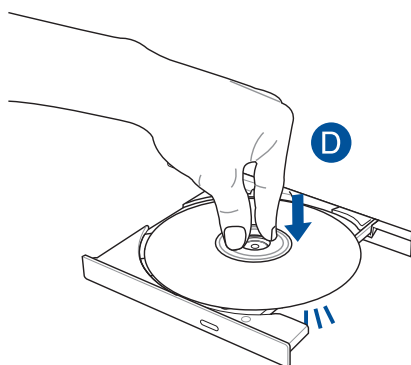

- E. Push the drive tray gently to close the optical drive.

NOTE: While data is being read, it is normal to hear some spinning and vibrating in the optical drive.

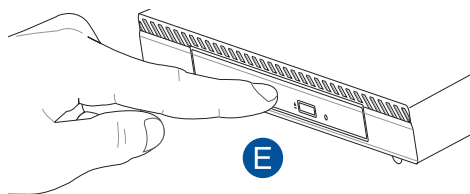

Manual eject hole

The manual eject hole is located on the optical drive door and is used to eject the optical drive tray in case the electronic eject button does not work.

To manually eject the optical drive tray, insert a straightened paper clip into the manual eject hole until the drive tray opens.

WARNING! Use the manual eject hole only when the electronic eject button does not work.

4

Supported operating systems

Working with Windows® 7

Starting for the first time

When you start your Mini Desktop PC for the first time, a series of screens appear to guide you in configuring the basic settings of your Windows® 7 operating system.

To start your Mini Desktop PC for the first time:

1. Turn on your Mini Desktop PC. Wait for a few minutes until the **Set Up Windows** screen appears.
2. From the dropdown list, select your preferred language then click **Next**.
3. From the dropdown lists, select your **Country or region, Time and currency**, and **Keyboard layout** then click **Next**.
4. Key in unique names for the **user name** and **Mini Desktop PC name** then click **Next**.
5. Key in the necessary information to set up your password, then click **Next**. You may also click **Next** to skip this step without entering any information.

NOTE: If you want to set up a password for your account later, refer to the *Setting up a user account and password* section in this user guide.

6. Carefully read the license terms. Tick **I accept the license terms** then click **Next**.
7. Select **Use recommended settings** or **Install important updates only** to set up the security settings of your Mini Desktop PC. To skip this step, select **Ask me later**.
8. Review your date and time settings. Click **Next**. The system loads the new settings then restarts.
9. After restarting, you may now start using your Mini Desktop PC.

Using the Start menu

The Start menu gives access to programs, utilities and other useful items on your Mini Desktop PC.

Launching items from the Start menu

1. From the Windows® taskbar, click .
2. From the Start menu, select the item that you want to launch.

Using Getting Started

The Getting Started option on the Start menu contains information on some basic tasks such as personalizing Windows®, adding new users, and transferring files to help you become more familiar with using Windows® 7.

To use Getting Started:

1. Click .
2. From the Start menu, select **Getting Started**.
3. From the list of available tasks, select the task that you want to do.

Using the taskbar

The taskbar allows you to launch and manage programs or items installed in your Mini Desktop PC.

Launching a program from the taskbar

From the Windows® taskbar, click an icon to launch it. Click the icon again to hide the program.

Pinning items on the jumplists

When you right-click an icon on the taskbar, a jumplist appears to provide quick-access to related links. You may pin items on the jumplist such as favorite websites, frequently visited folders or drives, and recently played media files.

To pin items on the jumplist:

1. Right-click an icon on the taskbar.
2. From the jumplist, right-click the item that you want to pin, then select **Pin to this list**.

Unpinning items from the jumplist

1. Right-click an icon on the taskbar.
2. From the jumplist, right-click the item you want to remove then select **Unpin from this list**.

Using the notification area

By default, the notification area shows these three icons:



Action Center notification

Click this icon to display all alerts and notifications. This also launches the Windows® Action Center.



Network connection

This icon displays the connection status and signal strength of the wired or wireless network connection.



Volume

Click this icon to adjust the volume of your Mini Desktop PC.

Displaying an alert notification

To display an alert notification, click  then click the message to open it.

NOTE: For more details, refer to the *Using Windows® Action Center* in this user guide.

Customizing icons and notifications

You may choose to display or hide icons and notifications on the taskbar or on the notification area.

To customize icons and notifications:

1. Click  on the notification area.
2. Click **Customize**.
3. From the dropdown list, select your preferred behavior for the icons or items you want to customize.

Using Windows® Explorer

Windows® Explorer allows you to view, manage, and organize your files folders.

Launching Windows® Explorer

Click  to launch the Start menu then click **Computer**.

Exploring files and folders

1. Launch Windows® Explorer.
2. From the navigation or view pane, browse for the location of your data.
3. Click the arrow on the breadcrumb bar to display to display the contents of the drive or folder.

Customizing the file or folder view

1. Launch Windows® Explorer.
2. Select the location of your data.
3. Click .
4. From the view menu, move the slider to select how you want to view the file or folder.

Arranging files

1. Launch Windows® Explorer.
2. From the **Arrange by** field, click to display the dropdown list.
3. Select your preferred arrangement type.

Sorting files

1. Launch Windows® Explorer.
2. Right-click anywhere on the View pane.
3. From the menu that appears, select **Sort by** then select your preferred sorting type.

Grouping files

1. Launch Windows® Explorer.
2. Right-click anywhere on the View pane.
3. From the menu that appears, select **Group by** then select your preferred grouping.

Adding a new folder

1. Launch Windows® Explorer.
2. From the toolbar, click **New folder**.
3. Key in a name for the new folder.

Backing up files

To set up a backup:

1. Click  > **All Programs > Maintenance > Backup and Restore.**
2. Click **Set up backup > Next.**
3. Select your backup destination then click **Next.**
4. Select **Let Windows choose (recommended)** or **Let me choose as your backup mode.**

NOTE: If you select **Let Windows choose**, Windows will not backup your programs, FAT-formatted files, Recycle Bin files, or temporary files that are 1GB or more.

5. Follow the onscreen instructions to finish the process.

Restoring your system settings

The Windows® System Restore feature creates a restore point the Mini Desktop PC's system settings are stored at a certain time and date. It allows you to restore or undo changes made to your Mini Desktop PC's system settings without affecting your personal data.

To restore your system:

1. Close all running applications.
2. Click  > **All Programs > Accessories > System Tools > System Restore.**
3. Follow the onscreen instructions to complete the process.

Using Windows® 7 Action Center

Windows® 7 Action Center provides alert notifications, security information, system maintenance information, and the option to automatically troubleshoot and fix some common Mini Desktop PC problems.

Launching Windows® 7 Action Center

1. Click  > **Open Action Center.**
2. Click the task that you want to do.

Using Windows® Update

Windows® update allows you to check and install the latest updates to enhance the security and performance of your Mini Desktop PC.

Launching Windows® Update

1. Click  to launch the Start menu.
2. Select **All Programs > Windows Update.**
3. Click the task that you want to do.

Setting up a user account and password

You may create user accounts and passwords for people to use on your Mini Desktop PC.

To set up a user account:

1. Click  > **Getting Started** > **Add new users**.
2. Select **Manage another account**.
3. Select **Create a new account**.
4. Type the user name.
5. Select either **Standard user** or **Administrator** as the user type.
6. Once finished, click **Create Account**.

To set up a password:

1. Select the user that you would like to set a password for.
2. Select **Create a password**.
3. Type your preferred password then confirm it.
4. Type a password hint.
5. Once finished, click **Create password**.

Using Windows® Help and Support

Windows® Help and Support provides you with guides and answers about using the applications included with your Windows® 7.

To launch Windows® Help and Support, click  > **Help and Support**.

NOTE: Connect to the Internet to get the latest Windows® online help.

Microsoft's Windows® 8.1 Downgrade Notices

- This system is preinstalled with Windows® 7 Professional operating system (OS) and also comes with a license and media for Windows® 8.1 OS. You may only use one version of the Windows® OS at a time. Switching between versions will require you to uninstall one version and install the other version.
- To enable downgrade to Windows® 7 Professional on this system, the BIOS settings on this system were changed to boot into a legacy BIOS mode. If the BIOS setting is not changed to native UEFI mode boot prior to installing, Windows® 8.1 will install; however, the following Windows® 8.1 functionality will not be enabled as they rely on UEFI mode boot:
 - Secure Boot
 - Seamless Boot experience
 - Network unlock for Bitlocker for systems with a Trusted Platform Module (TPM).
 - eDrive support

IMPORTANT!

- Your Mini Desktop PC comes preinstalled with Windows® 7 Professional. Downgrading to Windows® 8.1 deletes all of your system data on Windows® 7 Professional.
 - If your Mini Desktop PC package contents do not include a Windows® 7 Professional Recovery DVD, ensure that you create a backup before installing Windows® 8.1.
 - For more details about recovering your system in Windows® 8.1, refer to your Mini Desktop PC's user guide.
-

Changing your operating system to Windows® 8.1

1. Turn on your Mini Desktop PC. During POST, press <F2> to enter BIOS.
2. Insert the Windows® 8.1 Recovery DVD into the optical drive.
3. While on the BIOS setup, press the **F5** key then select **Yes** to load the system's optimized default settings.
4. Select the **Advanced** menu > **LPSS & SCC Configuration**.
5. Select **OS Selection** > **Windows 8.x**
6. Select the **Boot** menu > **Secure Boot menu**.
7. Select **OS Type** > **Windows UEFI mode**.
8. Press the **F10** key then select **Yes** to save the configuration and reboot your system.
9. While booting, your display shows the ASUS logo then the message **Press any key to boot from CD or DVD...** When you see this message, press any key on your keyboard to proceed with the downgrade.

NOTE: If your display returns to the BIOS screen, ensure that the Windows® 8.1 Recovery DVD has been inserted into the optical drive and repeat steps 3 to 8.

10. Carefully read the ASUS Recovery Tool license agreement. Tick the **I Agree** box then select **Accept**.
11. Select **No** to continue with the setup.

12. In the Choose your keyboard layout screen, select your language preference.

NOTE: If you can't find your preferred language from the current list, select **See more keyboard layouts** to view other language options.

13. Select **Troubleshoot > Reset your PC**. Wait for a few seconds to load the next Reset your PC screen.
14. Select **Next** to proceed.
15. In the next screen, select **Yes, repartition the drives**.
16. You can select **Just remove my files** or **Fully clean the drive** then **> Reset**. Wait until the installation process is completed.

NOTE: Choosing **Fully clean the drive** may take hours to complete its installation.

17. Follow the next set of onscreen instructions to configure the basic settings of your Mini Desktop PC. After configuring these basic items, the Windows® 8.1 Desktop mode appears.

NOTE: If you want to use the Start screen as your home screen, refer to the *Customizing your Start Screen* section of your Mini Desktop PC's user guide.

18. To reinstall drivers and applications, reinstall them using the bundled SCD or AP DVD with your device.

Working with Windows® 8.1

Starting for the first time

When you start your computer for the first time, a series of screens appear to guide you in configuring your Windows® 8.1 operating system.

To start your Mini Desktop PC for the first time:

1. Press the power button on your Mini Desktop PC. Wait for a few minutes until the setup screen appears.
2. From the setup screen, pick your region and a language to use on your Mini Desktop PC.
3. Carefully read the License Terms. Select I accept.
4. Follow the onscreen instructions to configure the following basic items:
 - Personalize
 - Get online
 - Settings
 - Your account
5. After configuring the basic items, Windows® 8.1 ceeds to install your apps and preferred settings. Ensure that your Mini Desktop PC is kept powered on during the setup process.
6. Once the setup process is complete, the Start screen appears.

Windows® UI

Windows® 8.1 comes with a tile-based user interface (UI) which allows you to organize and easily access Windows® apps from the Start screen. It also includes the following features that you can use while working on your Mini Desktop PC.

Start screen

The Start screen appears after successfully signing in to your user account. It helps organize all the applications you need in just one place.

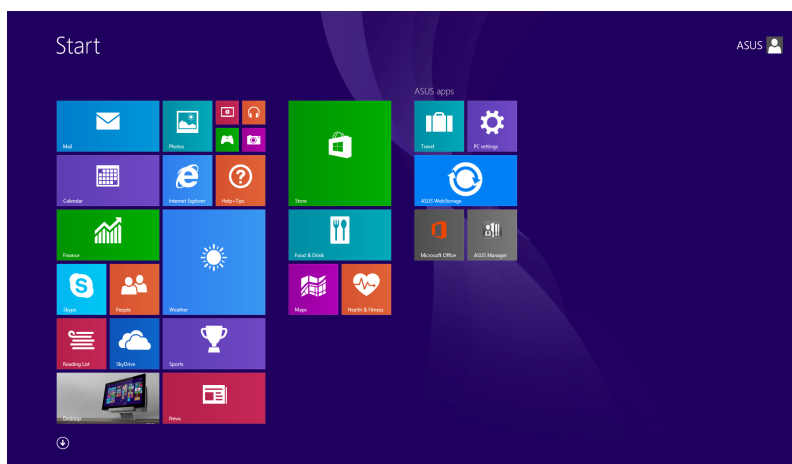

Windows® Apps

These are apps pinned on the Start screen and displayed on tiled-format for easy access.

NOTE: Some apps require signing in to your Microsoft account before they are fully launched.

Hotspots

Onscreen hotspots allow you to launch programs and access the settings of your Mini Desktop PC. The functions in these hotspots can be activated using your mouse.

Hotspots on a running app

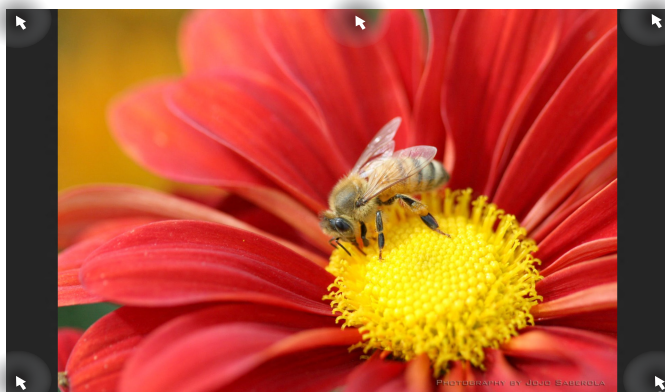

Hotspots on the Start screen

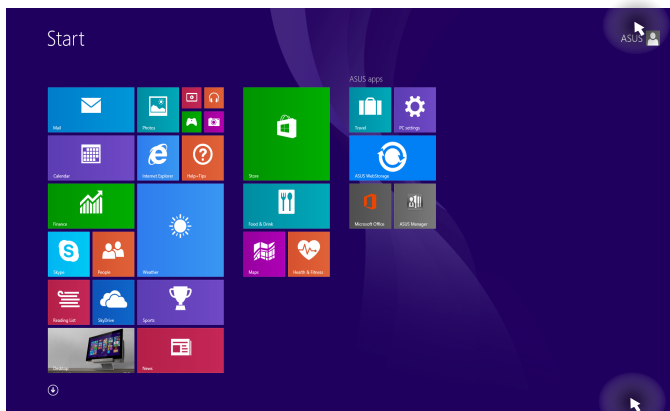

Hotspot

Action

upper left corner

Hover your mouse pointer on the upper left corner then Click on the recent app's thumbnail to revert back to that running app.

If you launched more than one app, slide down to show all running apps.

lower left corner

From a running app screen:

Hover your mouse pointer on the lower left corner then Click  to go back to the Start screen.

NOTE: You can also press the Windows key  on your keyboard to go back to the Start screen.

From the Start screen:

Hover your mouse pointer on the lower left corner then Click  to go back to that app.

Hotspot	Action
top side	<p>Hover your mouse pointer on the top side until it changes to a hand icon. Drag then drop the app to a new location.</p> <hr/> <p>NOTE: This hotspot function only works on a running app or when you want to use the Snap feature. For more details, refer to the Snap feature under <i>Working with Windows® apps</i>.</p> <hr/>
upper or lower right corner	<p>Hover your mouse pointer on the upper or lower right corner to launch the Charms bar.</p> <hr/>

Start button

Windows® 8.1 features the Start button which allows you to switch between the two most recent apps you opened. The Start button may be accessed from the Start screen, while on Desktop mode, and on any app that is currently open onscreen.

Start button on the Start screen

NOTE: The actual color of your Start button varies depending on the display settings you chose for your Start screen.

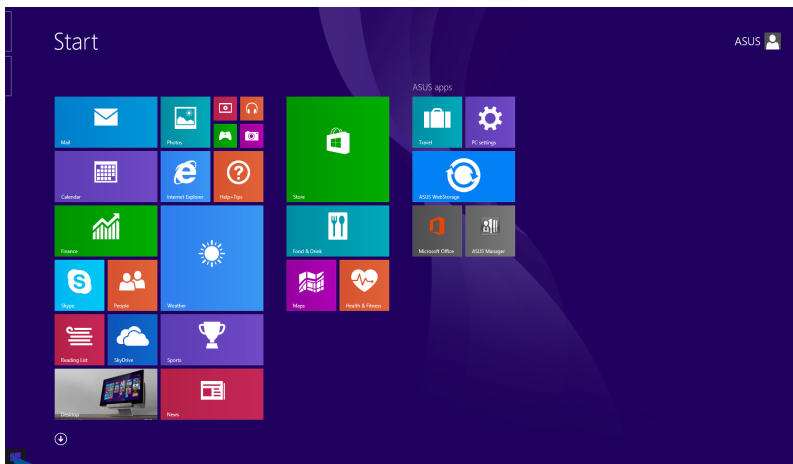

Hover your mouse pointer over the left corner of your Start screen or any opened app to call out the Start button.

Start button on Desktop mode

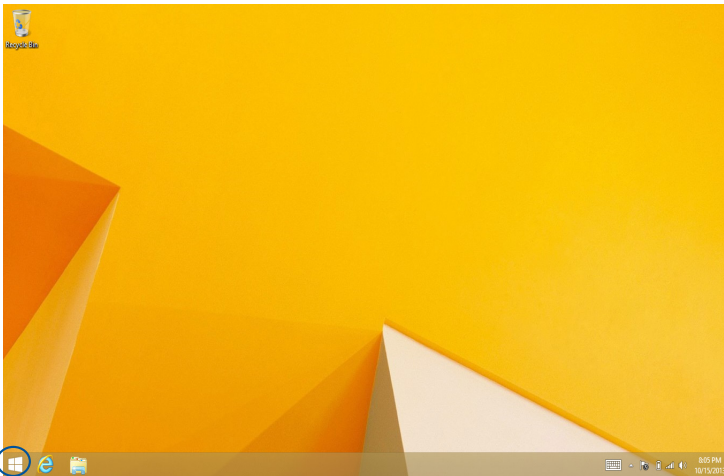

Context menu

The context menu appears as a box filled with quick access to some of the programs inside Windows® 8.1 when you right-click on the Start button.

The context menu also includes the following shut down options for your Mini Desktop PC: sign out, sleep, shut down, restart.

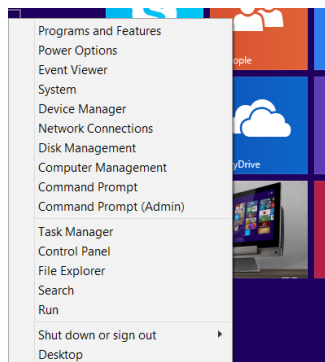

Customizing your Start screen

Windows® 8.1 also enables you to customize your Start screen, allowing you to boot directly to the Desktop mode and customize the arrangement of your apps onscreen.

To customize the settings of your Start screen:

1. Launch the Desktop.
2. Right-click anywhere on the taskbar, except on the Start button, to launch the pop-up window.
3. Click **Properties** then select the **Navigation** tab to tick the Navigation and Start screen options you want to use.

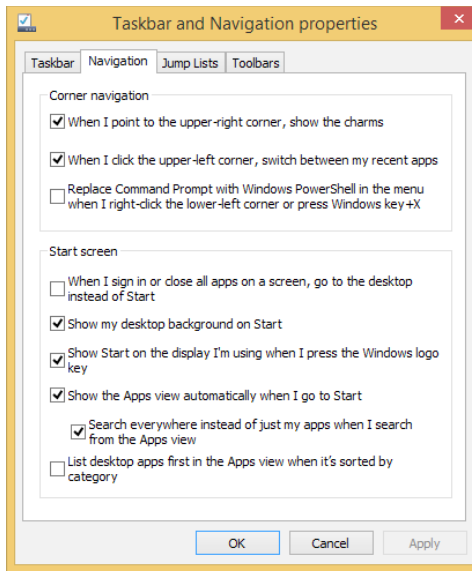

4. Click **Apply** to save the new settings then exit.

Working with Windows® apps



Use your Mini Desktop PC's optional keyboard and mouse to launch, customize, and close apps.

Launching apps



Position your mouse pointer over the app then left-click or tap once to launch it.



Press  twice then use the arrow keys to browse through the apps. Press  to launch an app.

Customizing apps

You can move, resize, unpin, or close apps from the Start screen using any of the following options:

Moving apps



Double-click on the app then drag and drop the app to a new location.

Resizing apps



Right-click on the app to activate the Customize bar, then click  and select an app tile size.

Unpinning apps



Right-click on the app to activate the Customize bar then click



Closing apps



1. Move your mouse pointer on the top side of the launched app then wait for the pointer to change to a hand icon.
2. Drag then drop the app to the bottom of the screen to close it.



From the running app's screen, press alt + f4.

Pinning more apps on the Start screen

You can pin more apps on the Start screen using the following options:



1. Launch the All Apps screen
2. Right-click on the apps that you want to add on the Start screen.
3. Click on the  icon to pin the selected apps on the Start screen.

Charms bar

The Charms bar is a toolbar that can be triggered on the right side of your screen. It consists of several tools that allow you to share applications and provide quick access for customizing the settings of your Mini Desktop PC.



Charms bar

Inside the Charm bar



Search

This charm allows you to look for files, applications, or programs in your Mini Desktop PC.



Share

This charm allows you to share applications via social networking sites or email.



Start

This charm reverts the display back to the Start screen. From the Start screen, you can also use this to revert back to a recently opened app.



Devices

This charm allows you to access and share files with the devices attached to your Mini Desktop PC such as an external display or printer.



Settings

This charm allows you to access the PC settings of your Mini Desktop PC.

Snap feature

The Snap feature displays two apps side-by-side, allowing you to work or switch between apps.

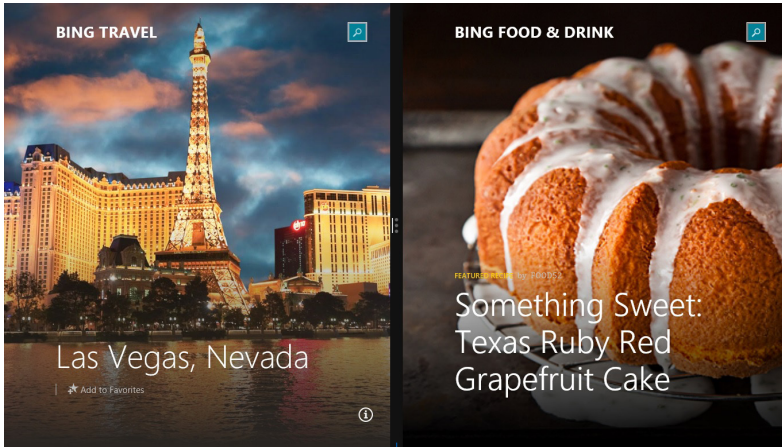

Snap bar

Using Snap

Activate and use Snap through any of the following options:







1. Launch the app you wish to snap.
2. Hover the mouse point on the top side of your screen.
3. Once the pointer changes to a hand icon, drag then drop the app to the left or right side of the display panel.
4. Launch another app.

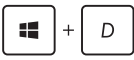
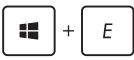
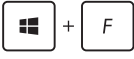

1. Launch the app you wish to snap.
2. Press  and the left or right arrow key to snap the app to the left or right pane.
3. Launch another app. This app is automatically placed in the empty pane.

Other keyboard shortcuts

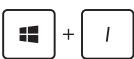
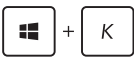
Using the keyboard, you can also use the following shortcuts to help you launch applications and navigate Windows® 8.1.

-  Switches between the Start screen and the last running app
-  Launches the desktop
-  Launches the **This PC** window on Desktop mode
-  Opens the **File** option from the **Search** charm
-  Opens the **Share** charm
-  Opens the **Settings** charm
-  Opens the **Devices** charm
-  Activates the Lock screen
-  Minimizes all currently active windows



Launches the **Project** pane



Opens the **Everywhere** option from the **Search** charm



Opens the **Run** window



Opens **Ease of Access Center**



Opens the **Settings** option under the **Search** charm



Opens the context menu of the Start button

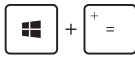

Launches the magnifier icon and zooms in your screen



Zooms out your screen



Opens the **Narrator Settings**

Connecting to the Internet

Access emails, surf the Internet, and share applications via social networking sites on or from your Mini Desktop PC using wireless/Wi-Fi or wired connection.

Setting up a Wi-Fi connection in Windows® 8.1

1. Launch the Charm bar from the Start screen or from any application mode.

NOTE: For details, refer to the section *Charm bar* under *Working with Windows® apps*.

2. From the Charm bar, select **Settings** and click the network icon .

3. Select the wireless network that you want to connect to from the list.
4. Click **Connect**.

NOTE: You may be prompted to enter a security key to connect to a secured wireless network.

Configuring your Wi-Fi bandwidth

1. Launch the Desktop mode then right-click on  on the taskbar.
2. Select **Open Network and Sharing Center**.
3. In the Network and Sharing Center window, select the Wi-Fi status beside **Connections**.
4. In the Wi-Fi status window, select **Properties > Configure** to launch your current network adapter's properties.
5. In the your current network adapter properties window, select the **Advanced** tab.
6. In the Advanced tab, select **Bandwidth Capability** under the **Property** option then select your preferred bandwidth setting by clicking on the drop-down box below **Value**.
7. Click **OK** to save and exit.

Wired connection

1. Use a network (RJ-45) cable to connect your Mini Desktop PC to a DSL/cable modem or a local area network (LAN).
2. Turn on your computer.
3. Configure the necessary Internet connection settings.

NOTES:

- For more details, refer to the sections *Configuring a dynamic IP/PPPoE network connection* or *Configuring a static IP network connection*.
 - Contact your Internet Service Provider (ISP) for details or assistance in setting up your Internet connection.
-

Configuring a dynamic IP/PPPoE network connection

To configure a dynamic IP/PPPoE or static IP network connection:

1. From the Start screen, click **Desktop** to launch the Desktop mode.
2. From the Windows® taskbar, right-click the network icon  and click **Open Network and Sharing Center**.
3. From the Open Network and Sharing Center screen, click **Change Adapter settings**.
4. Right-click on your LAN and select **Properties**.
5. Click **Internet Protocol Version 4(TCP/IPv4)** and click **Properties**.

6. Click **Obtain an IP address automatically** and click **OK**.

NOTE: Continue to the next steps if you are using PPPoE connection.

7. Return to the **Network and Sharing Center** and then click Set up a new connection or network.
8. Select **Connect to the Internet** and click **Next**.
9. Select **Broadband (PPPoE)** and click **Next**.
10. Enter your **Username, Password,** and **Connection name**. Click **Connect**.
11. Click **Close** to finish the configuration.
12. Click the network icon in the taskbar and click the connection you just created.
13. Enter your user name and password. Click **Connect** to connect to the Internet.

Configuring a static IP network connection

To configure a static IP network connection:

1. Repeat steps 1 to 4 of the previous section **Configuring a dynamic IP/PPPoE network connection**.
2. Click **Use the following IP address**.
3. Enter the IP address, Subnet mask and Gateway from your service provider.
4. If needed, enter the preferred DNS Server address and alternative address.
5. When done, click **OK**.

Turning your Mini Desktop PC off

Do either of the following to shut down your Mini Desktop PC:

- Click from the Charms bar then Click  > **Shut down** to do a normal shutdown.
- If your Mini Desktop PC is unresponsive, press and hold the power button for at least four (4) seconds until your Mini Desktop PC turns off.

Putting your Mini Desktop PC on sleep mode

Activate sleep mode on your Mini Desktop PC using either of the following procedures:

- Press the power button once.
- Launch the Desktop mode then press <Alt> + <F4> to launch the Shut Down window. Select **Sleep** from the drop-down list then select **OK**.

Windows® 8.1 lock screen

The Windows® 8.1 lock screen appears when you wake your Mini Desktop PC from sleep or hibernate mode. It also appears when you lock or unlock Windows® 8.1.

The lock screen can be customized to regulate access to your operating system. You can change its background display and access some of your apps while your Mini Desktop PC is still locked.



To proceed from the lock screen

1. Tap/click on the mouse or press any key on your Mini Desktop PC's keyboard.
2. (optional) If your account is password-protected, you need to key in the password to continue to the Start screen.

Customizing your lock screen

You can customize your lock screen to show your preferred photo, a photo slideshow, app updates, and quickly access your Mini Desktop PC's camera. To change the settings of your lock screen, you may refer to the following information:

Selecting a photo



1. Launch the Charms bar > **Settings**.
2. Select **Change PC Settings** > **Lock screen**.
3. Under the **Lock screen preview**, click **Browse** to select the photo you would like to use as a background on your lock screen.

Playing a slideshow



1. Launch the Charms bar > **Settings**.
2. Select **Change PC Settings** > **Lock screen**.
3. Under the **Lock screen preview**, move the **Play a slide show on the lock screen** slide bar to **On**.
4. Scroll down to customize the following options for your lock screen's slideshow:

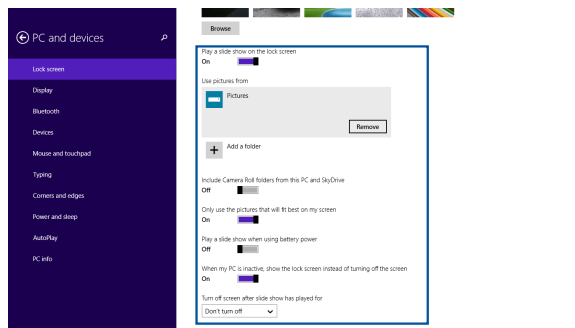

Adding app updates



1. Launch the Charms bar > **Settings**.
2. Select **Change PC Settings** > **Lock screen**.
3. Scroll down until you see the **Lock screen apps** option.
4. Use the following options to add the apps whose updates you would like to see from your lock screen:

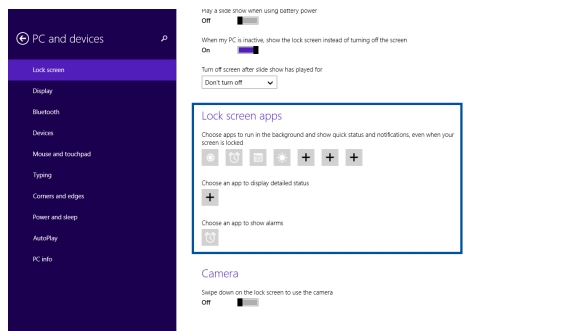

Activating your Mini Desktop PC camera from the lock screen

From the lock screen, you can swipe down to activate and use your Mini Desktop PC's camera. Refer to the following steps on how to enable this feature:



1. Launch the Charms bar > **Settings**.
2. Select **Change PC Settings** > **Lock screen**.
3. Scroll down until you see the **Camera** option.
4. Move the slide bar to **On**.

5

ASUS Business Manager

ASUS Business Manager

ASUS Business Manager provides a set of tools for customizing and maintaining your Mini Desktop PC.

Installing ASUS Business Manager

1. Insert the ASUS support DVD into the optical drive.
2. On the support CD windows, click **Utilities** > **ASUS Business Manager**.



3. On the ASUS Manager setup screen, select the applications you want to install.

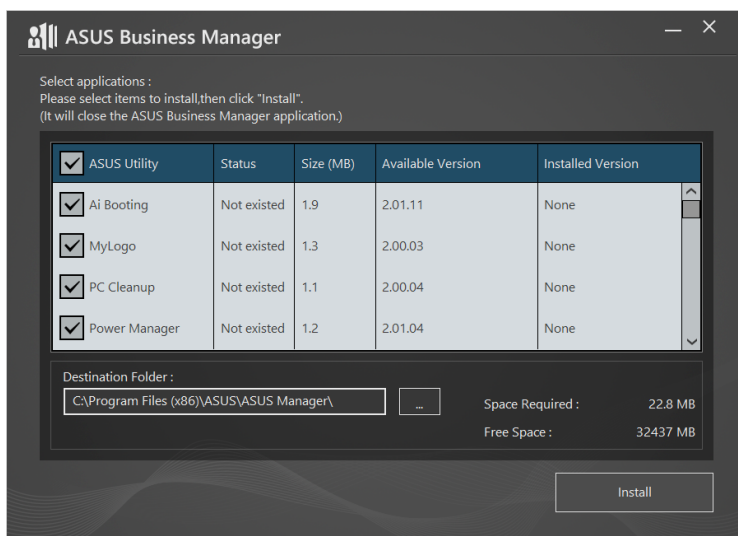

4. Click **Install**.
5. The system prompts you to reboot your system once installation is finished.

Starting ASUS Manager

Launch ASUS Manager from the Start menu by clicking **Start > ASUS > ASUS Manager**.

Icon view and List view

Click  to switch between the Icon view and List view when viewing all applications inside the ASUS Business Manager.

Icon View

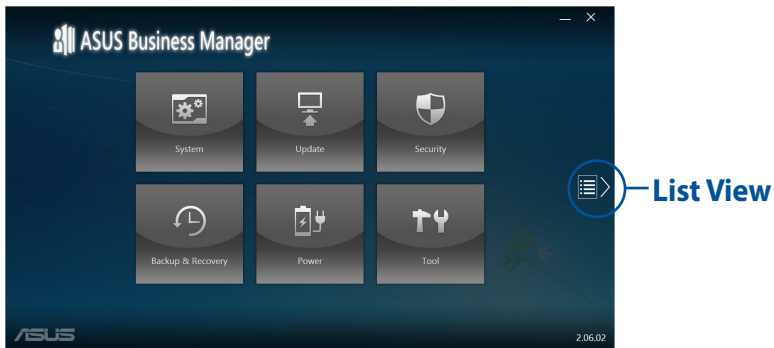

List View

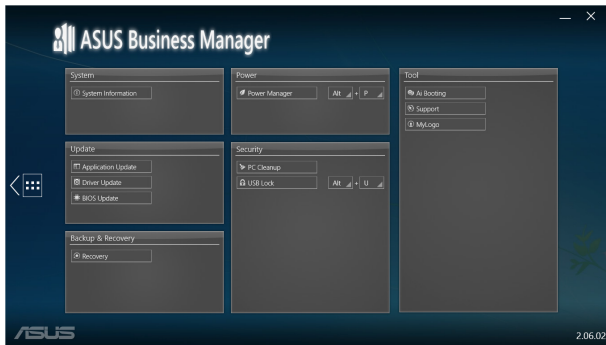

System

The System Information screen displays the hardware and software details of your Mini Desktop PC.

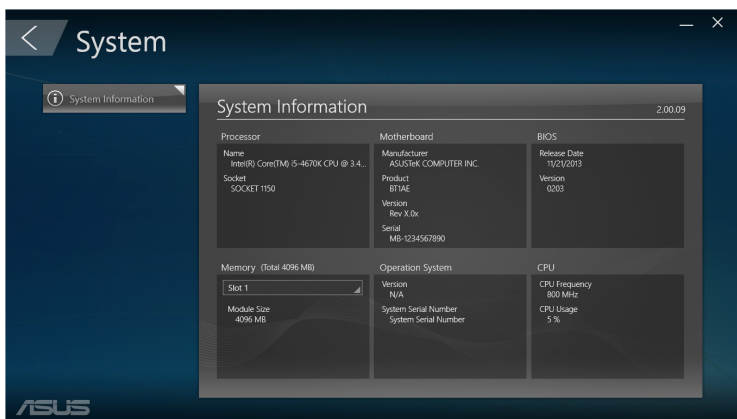

Update

Click **Update** on the main ASUS Manager screen to download and install hardware drivers, the latest BIOS, and updated ASUS applications.

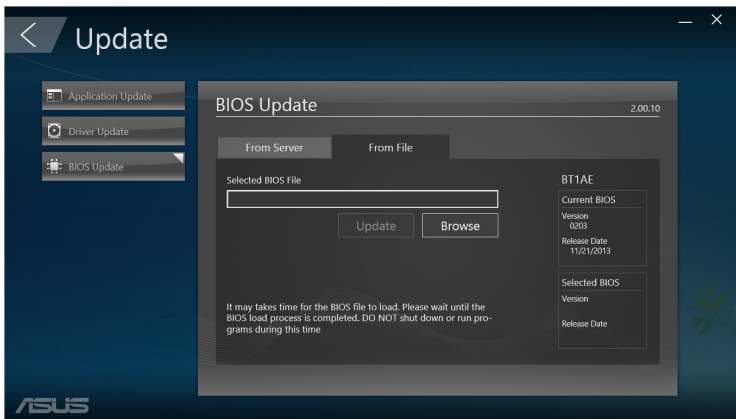

Security

Click **Security** on the main ASUS Manager screen to access PC Cleanup and USB Lock utilities.

PC Cleanup

PC Cleanup provides options to remove temporary and unnecessary files from your Mini Desktop PC to help free up hard drive space.

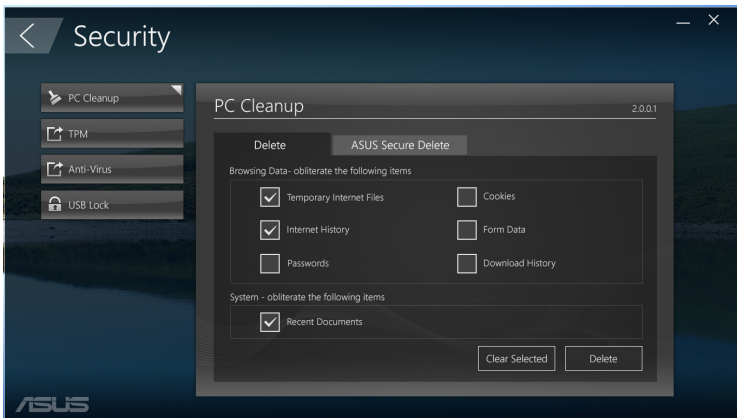

ASUS Secure Delete

ASUS Secure Delete keeps your files secure by making deleted files completely irrecoverable using a simple drag-and-drop interface.

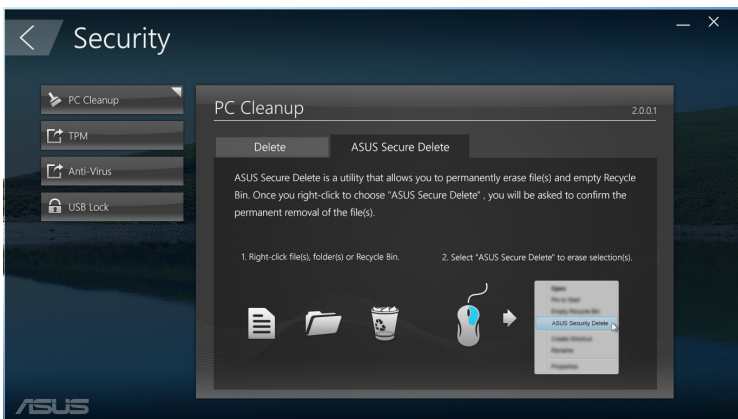

To use ASUS Secure Delete:

1. Once ASUS Secure Delete is launched, do any of the following to add files to the deletion box:
 - Drag and drop files into the deletion box.

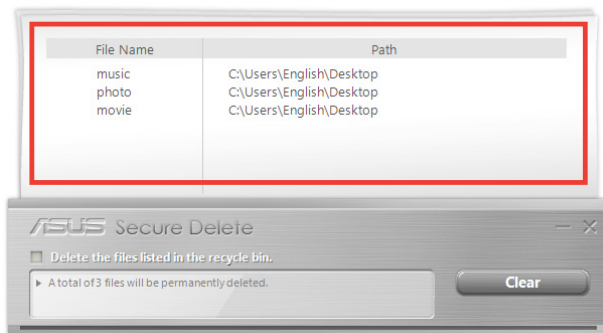

- Right-click the file then select **ASUS Secure Delete**.

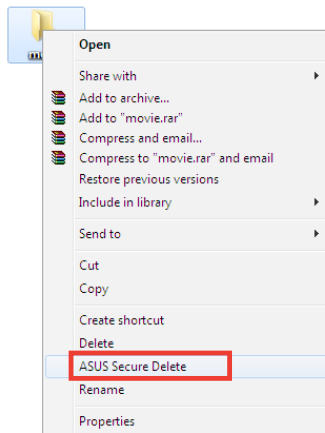

2. To remove a file from the deletion list, select the file then click

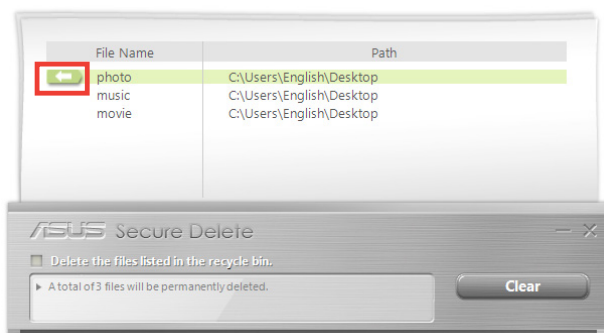

3. Tick **Delete the files listed in the recycle bin** if you want to permanently delete all the files in the recycle bin.

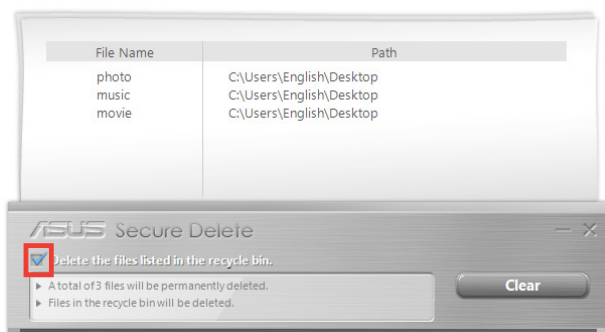

4. Click **Clear** then click **OK** on the confirmation message to permanently delete all the files listed on the deletion box and the recycle bin (if selected in step 3).

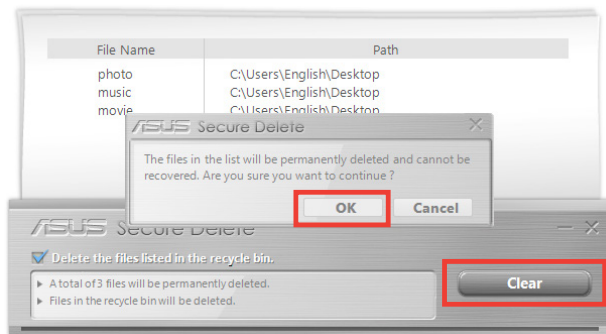

USB Lock

The USB Lock feature secures your USB ports, card reader, and optical drive from unwanted access by setting up a password.

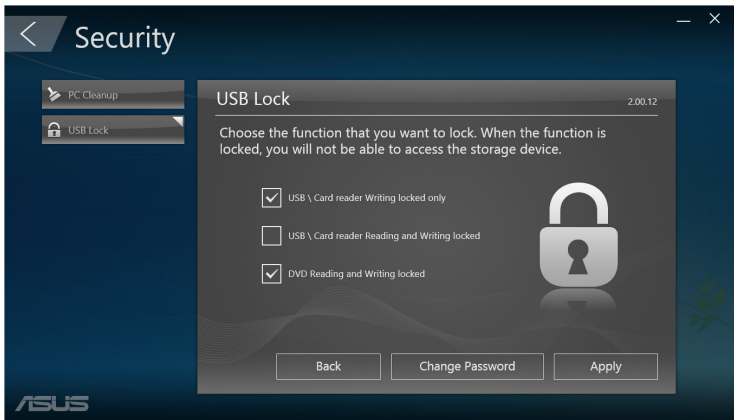

Backup & Recovery

Click **Recovery** on the main ASUS Manager screen to begin Windows maintenance tasks such as system restoration, adjusting startup settings, and repairing Windows with a recovery disk.



Power

Click **Power** on the main ASUS Manager screen to configure power management. With Power Manager, you can specify time settings for system hibernation, sleep, display, and hard drive activity.



Tool

Click **Tool** on the main ASUS Manager screen to access the Support screen, Ai Booting, or MyLogo.

Support

Support lists links to ASUS support websites and contact information.

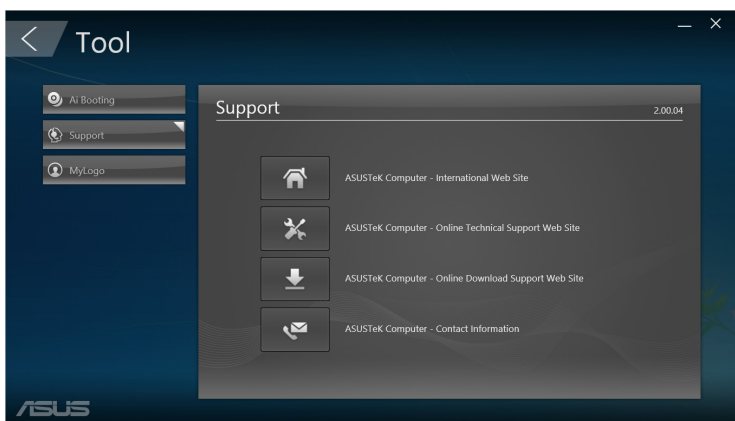

Ai Booting

Ai Booting displays a list of bootable storage devices. Select a device and click the left or right buttons to modify the boot sequence.

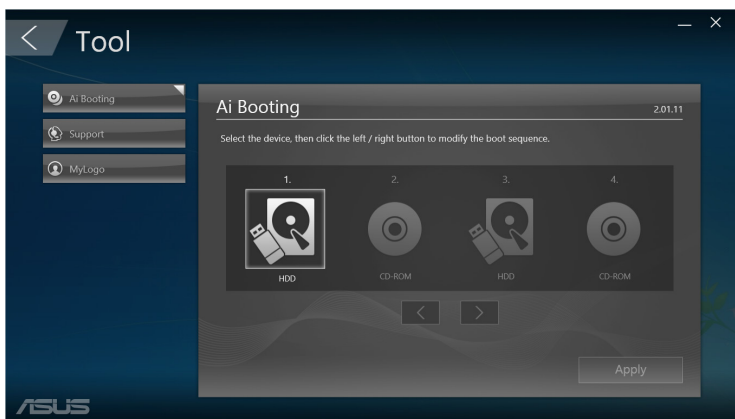

MyLogo

ASUS MyLogo allows you to customize the boot logo. The boot logo is the image that appears onscreen during the Power-On-Self-Tests (POST).



Changing the BIOS boot logo

1. Select any of the options, then click **Next**:
 - Change the BIOS boot logo and update the BIOS.
 - Change the BIOS boot logo only.



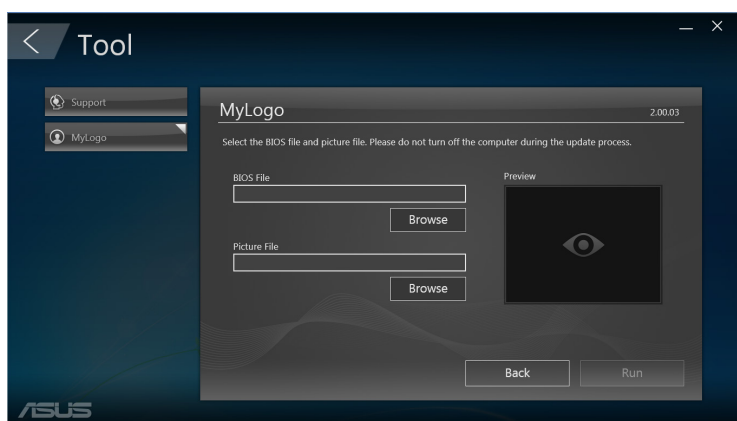



NOTE: Before selecting the first option, download the BIOS file to your Mini Desktop PC using ASUS Update.







2. Click **Browse** to locate the picture file that you want to use as the boot logo (and the downloaded BIOS if required) then click **Run**.
3. Follow the onscreen instructions to complete the process.

Intel® SBA (Small Business Advantage)

Intel® SBA is a combination of hardware and software utilities that provide unique security and productivity capabilities designed for small businesses.

Icons	Descriptions
	<p>Energy Saver</p> <p>Energy Saver allows you to schedule your computer to enter sleep mode at the end of your workday and wake up at the start of your workday. This helps reduce energy costs and improve productivity of your business. For more information, click  on the ASUS Business Suite main menu.</p>
	<p>PC Health Center</p> <p>PC Health Center lets you quickly and easily schedule all maintenance tasks such as data backup, system updates and disk defragmentation to run outside business hours even if your computer has been shut down, as long as your computer is plugged to a power source.</p> <p>With PC Health Center, your computer always runs at its best performance during business hours. For more information, click  on the ASUS Business Suite main menu.</p>
	<p>Software Monitor</p> <p>Software Monitor provides hardware-level monitoring of security-related applications that are installed on your computer and alerts you when a monitored application is disabled or attacked. For more information, click  on the ASUS Business Suite main menu.</p>

Icons	Descriptions
	<p>USB Blocker</p> <p>USB Blocker lets you quickly and easily specify the type of USB devices that can connect to your computer so as to prevent viruses and unauthorized data transfers on your computer. For more information, click  on the ASUS Business Suite main menu.</p>
	<p>Data Backup and Restore</p> <p>Data Backup and Restore automatically backs up your data even when your computer is powered off, as long as it is plugged in to a power source. For more information, click  on the ASUS Business Suite main menu.</p>

6

BIOS Setup

Knowing BIOS

The new ASUS UEFI BIOS is a Unified Extensible Interface that complies with UEFI architecture, offering a user-friendly interface that goes beyond the traditional keyboard- only.

BIOS controls to enable a more flexible and convenient mouse input. You can easily navigate the new UEFI BIOS with the same smoothness as your operating system.

NOTE: The term “BIOS” in this user manual refers to “UEFI BIOS” unless otherwise specified.

BIOS (Basic Input and Output System) stores system hardware settings such as storage device configuration, advanced power management, and boot device configuration that are needed for system startup in the motherboard CMOS. In normal circumstances, the default BIOS settings apply to most conditions to ensure optimal performance. DO NOT change the default BIOS settings except in the following circumstances:

- An error message appears on the screen during the system bootup and requests you to run the BIOS Setup.
- You have installed a new system component that requires further BIOS settings or update.

WARNING! Inappropriate BIOS settings may result to instability or boot failure. We strongly recommend that you change the BIOS settings only with the help of a trained service personnel.

Entering BIOS

- To enter BIOS Setup at startup, press <Delete> or <F2> during the Power-On Self Test (POST). If you do not press <Delete>, POST continues with its routines.
- To enter BIOS after startup, restart your Mini Desktop PC then press <Delete> or <F2> during POST.

BIOS menu options

NOTE: The BIOS screens in this section are for reference only. The actual screens may differ by model and territory.

Main

When you enter the BIOS Setup program, the Main menu screen appears. The Main menu provides you an overview of the basic system information, and allows you to set the system date, time, language, and security settings.



Advanced

The Advanced menu items allow you to change the settings for the CPU and other system devices.

WARNING! Take caution when changing the settings of the Advanced menu items. Incorrect field values can cause the system to malfunction.

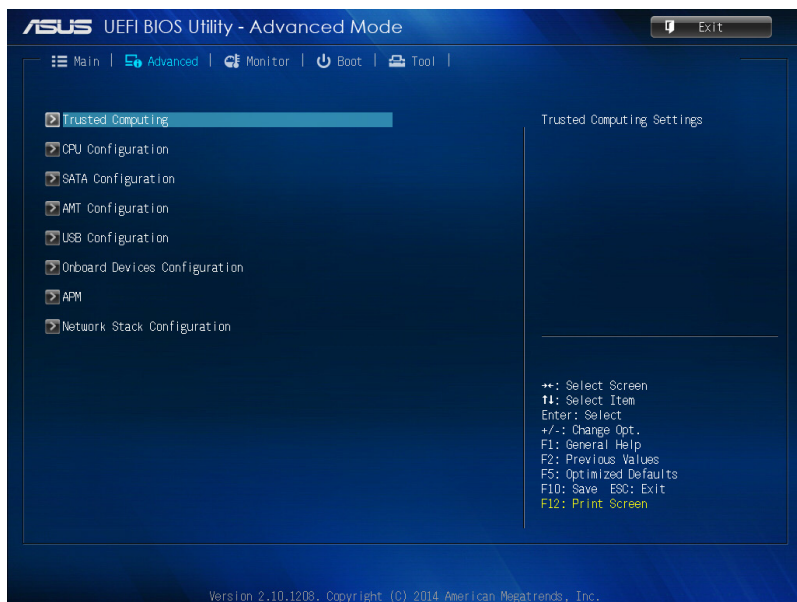

Boot

The Boot menu items allow you to change the system boot options. Scroll down to display the other BIOS items.

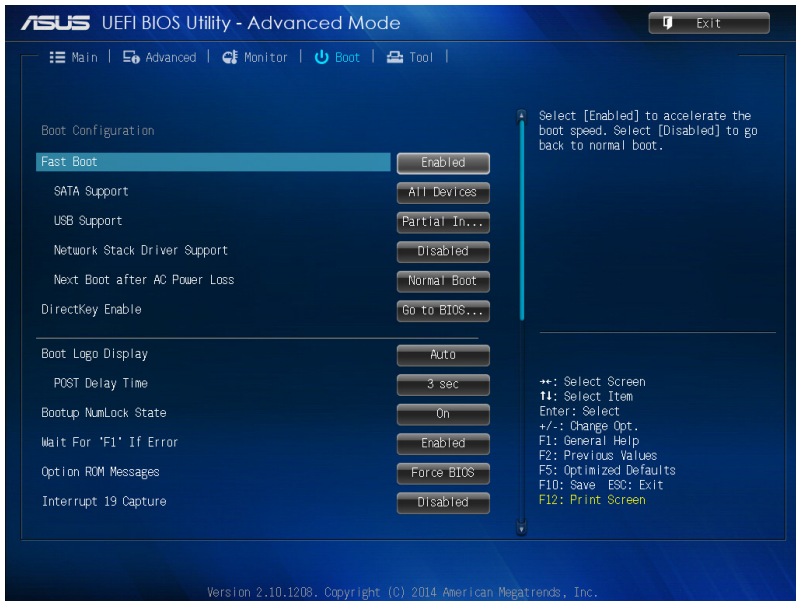

Tool

The Tools menu items allow you to configure options for special functions. Select an item then press <Enter> to display the submenu.

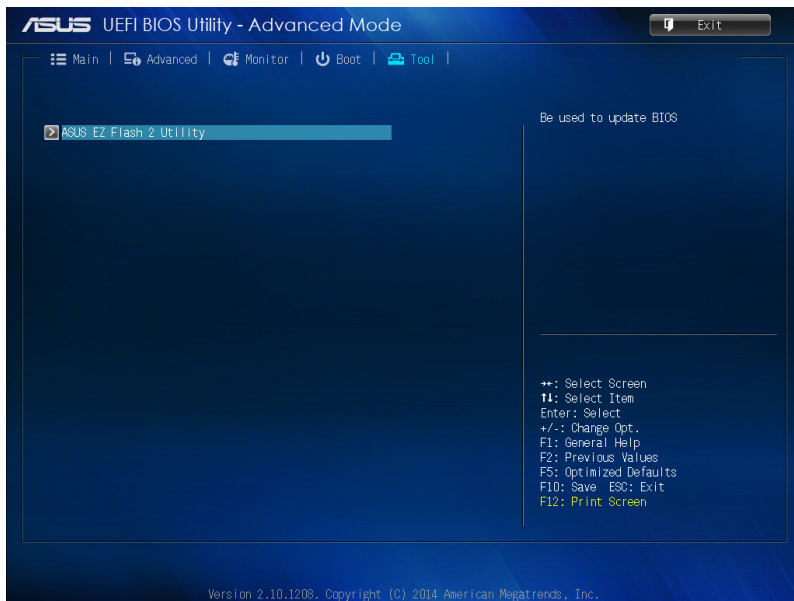

ASUS EZ Flash 2 Utility

ASUS EZ Flash 2 allows you to update the BIOS without having to use a bootable floppy disk or an OS-based utility.

NOTE: Before you start using this utility, download the latest BIOS from the ASUS website at www.asus.com

1. Insert the USB flash disk that contains the latest BIOS file to the USB port.
2. Launch the BIOS then select **Tool > ASUS EZ Flash 2 Utility**.

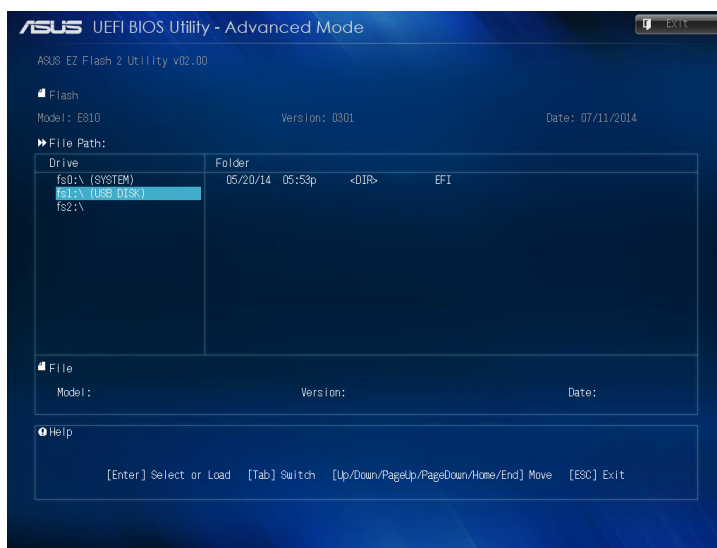

3. Press <Tab> to switch to the Drive field.
4. Press the Up/Down arrow keys to find the USB flash disk that contains the latest BIOS then press <Enter>.
5. Press <Tab> to switch to the Folder Info field.
6. Press the Up/Down arrow keys to find the BIOS file, and then press <Enter> to perform the BIOS update process. Reboot the system when the update process is done.

Configuring HDD access

In the BIOS, you can also set up a password-protected access to your HDD. Refer to the following steps to enable these settings.

NOTE: If you install a User Password, you will be prompted to input this before entering your Mini Desktop PC's operating system.

1. Press <Delete> or <F2> to enter BIOS during startup.
2. On the Main menu screen, click  below **HDD Security Configuration**.



3. Click **Set User Password**.

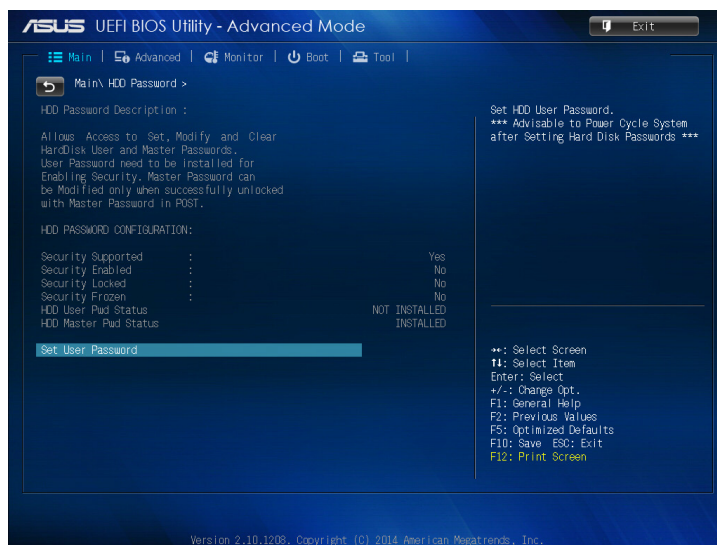

4. In the Create New Password box, key in a password, then press <Enter>.
5. Confirm the password when prompted.
6. Click **Exit** and select **Save Changes & Reset** to save the changes made.

To change the password for your HDD:

1. Press <Delete> to enter BIOS during startup.
2. On the Main menu screen, click  below **HDD Security Configuration**.
3. Click **Set User Password**.
4. In the Create New Password box, key in a new password, then press <Enter>.
5. Confirm the new password when prompted.
6. Click **Exit** and select **Save Changes & Reset** to save the changes made.

To clear the user password:

1. Press <Delete> to enter BIOS during startup.
2. On the Main menu screen, click  below **HDD Security Configuration**.
3. Click **Set User Password**.
4. In the Create New Password box, just press <Enter>.
5. Press <Enter> again when prompted to confirm the new password.
6. Click **Exit** and select **Save Changes & Reset** to save the changes made.

NOTE: If the password is successfully cleared, the **HDD User Pwd Status** becomes **NOT INSTALLED**.

Configuring USB ports

Using the BIOS, you can control access to some of the USB ports on your Mini Desktop PC.

1. Press <Delete> or <F2> to enter BIOS during startup.
2. Click **Advanced > USB Configuration > USB Single Port Control**.

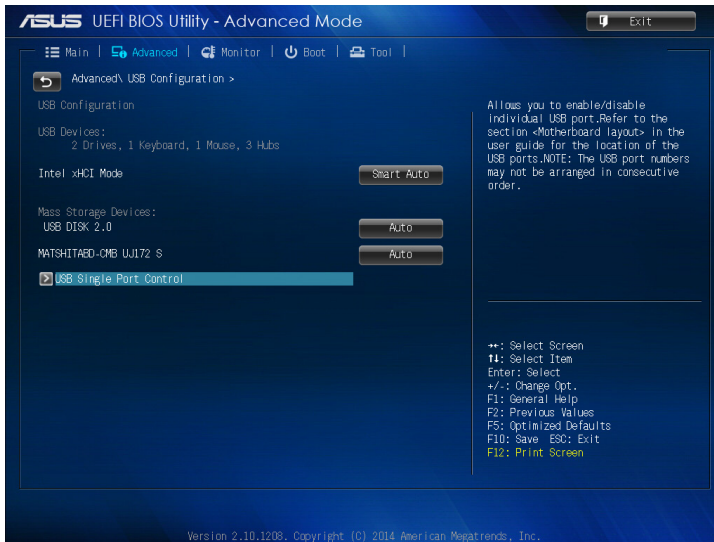

3. In the USB Single Port Control screen, select the USB port which you would like to disable or enable.

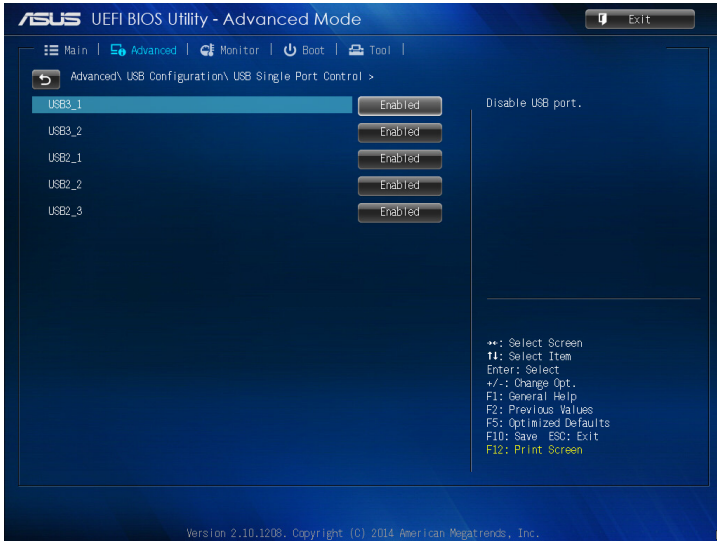

NOTE: Refer to the following illustrations for the location of the specified USB port on the BIOS screen:

main box front side

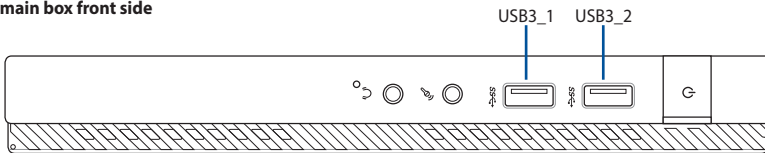

main box rear side

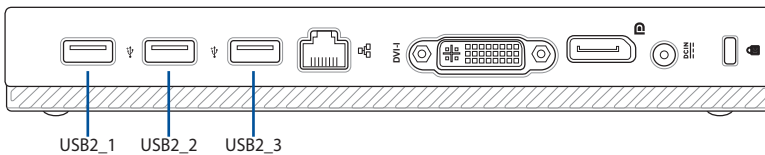

Troubleshooting

My computer cannot be powered on and the power LED on the front panel does not light up.

- Check if your computer is properly connected.
- Check if the wall outlet is functioning.
- Check if the Power Supply Unit is switched on. Refer to the *Powering On* section in Chapter 2.

My computer hangs.

Do the following to close the programs that are not responding:

1. Simultaneously press <Alt> + <Ctrl> + <Delete> keys on the keyboard, then click Task Manager.
2. Do the following based on the operating system:

On Windows® 7:

- a) Click **Applications** tab.
- b) Select the program that is not responding, then click **End Task**.

On Windows® 8.1:

Under Task Manager in the Processes tab, select the program that is not responding, then click **End Task**.

- If the keyboard is not responding. Press and hold the Power button on the top of your chassis until the computer shuts down. Then press the Power button to turn it on.

I cannot connect to a wireless network using the ASUS WLAN Card (on selected models only).

- Ensure that you enter the correct network security key for the wireless network you want to connect to.
- Connect the external antennas (optional) to the antenna connectors on the ASUS WLAN Card and place the antennas on the top of your computer chassis for the best wireless performance.

The arrow keys on the number key pad are not working.

Check if the Number Lock LED is off. When the Number Lock LED is on, the keys on the number key pad are used to input numbers only. Press the Number Lock key to turn the LED off if you want to use the arrow keys on the number key pad.

No display on the monitor.

- Check if the monitor is powered on.
- Ensure that your monitor is properly connected to the video output port on your computer.
- If your computer comes with a discrete graphics card, ensure that you connect your monitor to a video output port on the discrete graphics card.
- Check if any of the pins on the monitor video connector is bent. If you discover bent pins, replace the monitor video connector cable.
- Check if your monitor is plugged to a power source properly.
- Refer to the documentation that came with your monitor for more troubleshooting information.

When using multiple monitors, only one monitor has display.

- Ensure that the both monitors are powered on.
- During POST, only the monitor connected to the VGA port has display. The dual display function works only under Windows.
- When a graphics card is installed on your computer, ensure that you connect the monitors to the output port on the graphics card.
- Check if the multiple displays settings are correct.

My computer cannot detect my USB storage device.

- The first time you connect your USB storage device to your computer, Windows automatically installs a driver for it. Wait for a while and go to **My Computer** to check if the USB storage device is detected.
- Connect your USB storage device to another computer to test if the USB storage device is broken or malfunctions.

I want to restore or undo changes to my computer's system settings without affecting my personal files or data.

On Windows® 7:

The Windows® System Restore feature allows you to restore or undo changes to your computer's system settings without affecting your personal data such as documents or photos. For more details, refer to the section Restoring your system in Chapter 4.

On Windows® 8.1:

You can use Windows® 8.1 Refresh everything without affecting your files recovery option to restore or undo changes to your computer's system settings without affecting your personal data such as documents or photos.

To use this recovery option, click **Settings > PC Settings > Update and recovery > Recovery from the Charms bar**, select **Refresh everything without affecting your files**, and click **Get Started**.

When I play audio and video files, why can't I hear any sound from my Mini Desktop PC's audio speakers?

- Check if your speakers were set to mute.
- Check if a headphone jack is connected to your Mini Desktop PC and remove it.

The DVD drive cannot read a disc.

- Check if the disc is placed with the label side facing up.
- Check if the disc is centered in the tray, especially for the discs with non-standard size or shape.
- Check if the disc is scratched or damaged.

The DVD drive eject button is not responding.

1. On Windows® 7, click  > **Computer**.

On Windows® 8.1, hover your mouse pointer over the lower left corner of Windows® desktop then right-click on the Start Screen's thumbnail. From the popup menu, click **File Explorer** to open the **Computer** screen.

2. Right-click  DVD RW Drive, then click **Eject** from the menu.

Power

Problem	Possible Cause	Action
No power (The power indicator is off)	Incorrect power voltage	<ul style="list-style-type: none">• Set your computer's power voltage switch to your area's power requirements.• Adjust the voltage settings. Ensure that the power cord is unplugged from the power outlet.
	Your computer is not turned on.	Press the power key on the front panel to ensure that your computer is turned on.
	Your computer's power cord is not properly connected.	<ul style="list-style-type: none">• Ensure that the power cord is properly connected.• Use other compatible power cord.
	PSU (Power supply unit) problems	Contact the ASUS Service Center about installing another PSU on your computer.

Display

Problem	Possible Cause	Action
No display output after turning the computer on (Black screen)	The signal cable is not connected to the correct VGA port on your computer.	<ul style="list-style-type: none">• Connect the signal cable to the correct display port (onboard VGA or discrete VGA port).• If you are using a discrete VGA card, connect the signal cable to the discrete VGA port.
	Signal cable problems	Try connecting to another monitor.

LAN

Problem	Possible Cause	Action
Cannot access the Internet	The LAN cable is not connected.	Connect the LAN cable to your computer.
	LAN cable problems	Ensure the LAN LED is on. If not, try another LAN cable. If it still does not work, contact the ASUS service center.
	Your computer is not properly connected to a router or hub.	Ensure that your computer is properly connected to a router or hub.
	Network settings	Contact your Internet Service Provider (ISP) for the correct LAN settings.
	Problems caused by the anti-virus software	Close the anti-virus software.
	Driver problems	Reinstall the LAN driver

Audio

Problem	Possible Cause	Action
No Audio	Speaker or headphone is connected to the wrong port.	<ul style="list-style-type: none">• Refer to your computer's user manual for the correct port.• Disconnect and reconnect the speaker to your computer.
	Speaker or headphone does not work.	Try using another speaker or headphone.
	The front and back audio ports do not work.	Try both the front and back audio ports. If one port failed, check if the port is set to multi-channel.
	Driver problems	Reinstall the audio driver

System

Problem	Possible Cause	Action
System speed is too slow	Too many programs are running.	Close some of the programs.
	Computer virus attack	<ul style="list-style-type: none"> • Use an anti-virus software to scan for viruses and repair your computer. • Reinstall the operating system.
The system often hangs or freezes.	Hard disk drive failure	<ul style="list-style-type: none"> • Send the damaged hard disk drive to ASUS Service Center for servicing. • Replace with a new hard disk drive.
	Memory module problems	<ul style="list-style-type: none"> • Replace with compatible memory modules. • Remove the extra memory modules that you have installed, then try again. • Contact the ASUS Service Center for assistance.
	There is not enough air ventilation for your computer.	Move your computer to an area with better air flow.
	Incompatible software are installed.	Reinstall the OS and reinstall compatible software.

CPU

Problem	Possible Cause	Action
Too noisy right after turning on the computer.	Your computer is booting up.	It is normal. The fan runs on its full speed when the computer is powering on. The fan slows down after entering the OS.
	The BIOS settings have been changed.	Restore the BIOS to its default settings.
	Old BIOS version	Update the BIOS to the latest version. Visit the ASUS Support site at http://support.asus.com to download the latest BIOS versions.

CPU

Problem	Possible Cause	Action
Computer is too noisy when in use.	The CPU fan has been replaced.	Ensure that you are using a compatible or ASUS-recommended CPU fan.
	There is not enough air ventilation for the computer.	Ensure that your computer is working in an area with good air flow.
	The system temperature is too high.	<ul style="list-style-type: none">• Update the BIOS.• If you know how to reinstall the motherboard, try to clean the inner space of the chassis.• Contact the ASUS Service Center for assistance.

NOTE: If the problem still persists, refer to your Mini Desktop PC's warranty card and contact the ASUS Service Center. Visit the ASUS Support site at <http://support.asus.com> for the service center information.

Appendix

ASUS Recycling/Takeback Services

ASUS recycling and takeback programs come from our commitment to the highest standards for protecting our environment. We believe in providing solutions for you to be able to responsibly recycle our products, batteries, other components, as well as the packaging materials. Please go to <http://csr.asus.com/english/Takeback.htm> for the detailed recycling information in different regions.

REACH

Complying with the REACH (Registration, Evaluation, Authorisation, and Restriction of Chemicals) regulatory framework, we published the chemical substances in our products at ASUS REACH website at <http://csr.asus.com/english/REACH.htm>

Declaration of Conformity (R&TTE directive 1999/5/EC)

The following items were completed and are considered relevant and sufficient:

- Essential requirements as in [Article 3]
- Protection requirements for health and safety as in [Article 3.1a]
- Testing for electric safety according to [EN 60950]
- Protection requirements for electromagnetic compatibility in [Article 3.1b]
- Testing for electromagnetic compatibility in [EN 301 489-1] & [EN 301 489-17]
- Effective use of the radio spectrum as in [Article 3.2]
- Radio test suites according to [EN 300 328]

Wireless Operation Channel for Different Domains

N. America	2.412-2.462 GHz	Ch01 through CH11
Japan	2.412-2.484 GHz	Ch01 through Ch14
Europe ETSI	2.412-2.472 GHz	Ch01 through Ch13

CE Mark Warning

This is a Class B product, in a domestic environment, this product may cause radio interference, in which case the user may be required to take adequate measures.



CE marking for devices without wireless LAN/ Bluetooth

The shipped version of this device complies with the requirements of the EEC directives 2004/108/EC "Electromagnetic compatibility" and 2006/95/EC "Low voltage directive".



CE marking for devices with wireless LAN/ Bluetooth

This equipment complies with the requirements of Directive 1999/5/EC of the European Parliament and Commission from 9 March, 1999 governing Radio and Telecommunications Equipment and mutual recognition of conformity.

ⓘ is for class II device.

Federal Communications Commission Statement

This device complies with Part 15 of the FCC Rules. Operation is subject to the following two conditions:

- This device may not cause harmful interference; and
- This device must accept any interference received including interference that may cause undesired operation.

This equipment has been tested and found to comply with the limits for a Class B digital device, pursuant to Part 15 of the FCC Rules.

These limits are designed to provide reasonable protection against harmful interference in a residential installation. This equipment generates, uses and can radiate radio frequency energy and, if not installed and used in accordance with manufacturer's instructions, may cause harmful interference to radio communications. However, there is no guarantee that interference will not occur in a particular installation. If this equipment does cause harmful interference to radio or television reception, which can be determined by turning the equipment off and on, the user is encouraged to try to correct the interference by one or more of the following measures:

- Reorient or relocate the receiving antenna.
- Increase the separation between the equipment and receiver.
- Connect the equipment to an outlet on a circuit different from that to which the receiver is connected.
- Consult the dealer or an experienced radio/TV technician for help.

IMPORTANT! The use of shielded cables for connection of the monitor to the graphics card is required to assure compliance with FCC regulations. Changes or modifications to this unit not expressly approved by the party responsible for compliance could void the user's authority to operate this equipment.

Lithium Battery Warning

CAUTION: Danger of explosion if battery is incorrectly replaced. Replace only with the same or equivalent type recommended by the manufacturer. Dispose of used batteries according to the manufacturer's instructions.

RF Exposure Warning

This equipment must be installed and operated in accordance with provided instructions and the antenna(s) used for this transmitter must be installed to provide a separate distance of at least 20 cm from all persons and must not be co-located or operating in conjunction with any other antenna or transmitter. End-users and installers must be provided with antenna installation instructions and transmitter operating conditions for satisfying RF exposure compliance.

IC: Canadian Compliance Statement

Complies with the Canadian ICES-003 Class B specifications. This device complies with RSS 210 of Industry Canada. This Class B device meets all the requirements of the Canadian interference-causing equipment regulations.

This device complies with Industry Canada license exempt RSS standard(s). Operation is subject to the following two conditions: (1) this device may not cause interference, and (2) this device must accept any interference, including interference that may cause undesired operation of the device.

Cet appareil numérique de la Classe B est conforme à la norme NMB-003 du Canada.

Cet appareil numérique de la Classe B respecte toutes les exigences du Règlement sur le matériel brouilleur du Canada.

Cet appareil est conforme aux normes CNR exemptes de licence d'Industrie Canada. Le fonctionnement est soumis aux deux conditions suivantes :

- (1) cet appareil ne doit pas provoquer d'interférences et
- (2) cet appareil doit accepter toute interférence, y compris celles susceptibles de provoquer un fonctionnement non souhaité de l'appareil.

Canadian Department of Communications Statement

This digital apparatus does not exceed the Class B limits for radio noise emissions from digital apparatus set out in the Radio Interference Regulations of the Canadian Department of Communications.

This class B digital apparatus complies with Canadian ICES-003.

VCCI: Japan Compliance Statement

VCCI Class B Statement

この装置は、クラスB情報技術装置です。この装置は、家庭環境で使用することを目的としていますが、この装置がラジオやテレビジョン受信機に近接して使用されると、受信障害を引き起こすことがあります。

取扱説明書に従って正しい取り扱いをして下さい。

VCCI-B

KC: Korea Warning Statement

B급 기기 (가정용 방송통신기자재)

이 기기는 가정용(B급) 전자파적합기기로서 주로 가정에서 사용하는 것을 목적으로 하며, 모든 지역에서 사용할 수 있습니다.

*당해 무선설비는 전파혼신 가능성이 있으므로 인명안전과 관련된 서비스는 할 수 없습니다.

RF Equipment Notices

CE: European Community Compliance Statement

The equipment complies with the RF Exposure Requirement 1999/519/EC, Council Recommendation of 12 July 1999 on the limitation of exposure of the general public to electromagnetic fields (0–300 GHz). This wireless device complies with the R&TTE Directive.

Wireless Radio Use

This device is restricted to indoor use when operating in the 5.15 to 5.25 GHz frequency band.

Exposure to Radio Frequency Energy

The radiated output power of the Wi-Fi technology is below the FCC radio frequency exposure limits. Nevertheless, it is advised to use the wireless equipment in such a manner that the potential for human contact during normal operation is minimized.

FCC Bluetooth Wireless Compliance

The antenna used with this transmitter must not be colocated or operated in conjunction with any other antenna or transmitter subject to the conditions of the FCC Grant.

Bluetooth Industry Canada Statement

This Class B device meets all requirements of the Canadian interference-causing equipment regulations.

Cet appareil numérique de la Class B respecte toutes les exigences du Règlement sur le matériel brouilleur du Canada.

BSMI: Taiwan Wireless Statement

無線設備的警告聲明

經型式認證合格之低功率射頻電機，非經許可，公司、商號或使用者均不得擅自變更射頻、加大功率或變更原設計之特性及功能。低功率射頻電機之使用不得影響飛航安全及干擾合法通信；經發現有干擾現象時，應立即停用，並改善至無干擾時方得繼續使用。前項合法通信指依電信法規定作業之無線通信。低功率射頻電機須忍受合法通信或工業、科學及醫療用電波輻射性電機設備之干擾。

於 5.25GHz 至 5.35GHz 區域內操作之
無線設備的警告聲明

工作頻率 5.250 ~ 5.350GHz 該頻段限於室內使用。

Japan RF Equipment Statement

この製品は、周波数帯域5.15～5.35GHzで動作しているときは、屋内においてのみ使用可能です。

KC (RF equipment)

대한민국 규정 및 준수

방통위고시에 따른 고지사항

해당 무선설비는 운용 중 전파혼신 가능성이 있음,

이 기기는 인명안전과 관련된 서비스에 사용할 수 없습니다.

Optical Drive Safety Information

Laser Safety Information

CD-ROM Drive Safety Warning

CLASS 1 LASER PRODUCT

WARNING! To prevent exposure to the optical drive's laser, do not attempt to disassemble or repair the optical drive by yourself. For your safety, contact a professional technician for assistance.

Service warning label

WARNING! INVISIBLE LASER RADIATION WHEN OPEN. DO NOT STARE INTO BEAM OR VIEW DIRECTLY WITH OPTICAL INSTRUMENTS.

CDRH Regulations

The Center for Devices and Radiological Health (CDRH) of the U.S. Food and Drug Administration implemented regulations for laser products on August 2, 1976. These regulations apply to laser products manufactured from August 1, 1976. Compliance is mandatory for products marketed in the United States.

WARNING! Use of controls or adjustments or performance of procedures other than those specified herein or in the laser product installation guide may result in hazardous radiation exposure.

ENERGY STAR complied product



ENERGY STAR is a joint program of the U.S. Environmental Protection Agency and the U.S. Department of Energy helping us all save money and protect the environment through energy efficient products and practices.

All ASUS products with the ENERGY STAR logo comply with the ENERGY STAR standard, and the power management feature is enabled by default. The monitor and computer are automatically set to sleep after 10 and 30 minutes of user inactivity. To wake your computer, click the mouse or press any key on the keyboard. Please visit <http://www.energy.gov/powermanagement> for detail information on power management and its benefits to the environment. In addition, please visit <http://www.energystar.gov> for detail information on the ENERGY STAR joint program.

NOTE: Energy Star is NOT supported on FreeDOS and Linux-based operating systems.

ASUS Contact Information

ASUSTeK COMPUTER INC.

Address	15 Li-Te Road, Peitou, Taipei, Taiwan 11259
Telephone	+886-2-2894-3447
Fax	+886-2-2890-7798
E-mail	info@asus.com.tw
Website	www.asus.com.tw

Technical Support

Telephone	0800-093-456
Online support	support.asus.com

ASUS COMPUTER INTERNATIONAL (America)

Address	800 Corporate Way, Fremont, CA 94539, USA
Fax	+1-510-608-4555
Website	usa.asus.com

Technical Support

Telephone	+1-812-282-2787
Online support	support.asus.com

ASUS COMPUTER GmbH (Germany and Austria)

Address Harkort Str. 21-23, D-40880 Ratingen, Germany

Fax +49-2102-959911

Website www.asus.de

Technical Support

Telephone +49-1805-010923

Support Fax +49-2102-9599-11

Online support support.asus.com