



PE100A

Embedded Computer

User Manual



E22327

Revised Edition V7

August 2023

COPYRIGHT INFORMATION

No part of this manual, including the products and software described in it, may be reproduced, transmitted, transcribed, stored in a retrieval system, or translated into any language in any form or by any means, except documentation kept by the purchaser for backup purposes, without the express written permission of ASUSTeK COMPUTER INC. ("ASUS").

ASUS PROVIDES THIS MANUAL "AS IS" WITHOUT WARRANTY OF ANY KIND, EITHER EXPRESS OR IMPLIED, INCLUDING BUT NOT LIMITED TO THE IMPLIED WARRANTIES OR CONDITIONS OF MERCHANTABILITY OR FITNESS FOR A PARTICULAR PURPOSE. IN NO EVENT SHALL ASUS, ITS DIRECTORS, OFFICERS, EMPLOYEES OR AGENTS BE LIABLE FOR ANY INDIRECT, SPECIAL, INCIDENTAL, OR CONSEQUENTIAL DAMAGES (INCLUDING DAMAGES FOR LOSS OF PROFITS, LOSS OF BUSINESS, LOSS OF USE OR DATA, INTERRUPTION OF BUSINESS AND THE LIKE), EVEN IF ASUS HAS BEEN ADVISED OF THE POSSIBILITY OF SUCH DAMAGES ARISING FROM ANY DEFECT OR ERROR IN THIS MANUAL OR PRODUCT.

Products and corporate names appearing in this manual may or may not be registered trademarks or copyrights of their respective companies, and are used only for identification or explanation and to the owners' benefit, without intent to infringe.

SPECIFICATIONS AND INFORMATION CONTAINED IN THIS MANUAL ARE FURNISHED FOR INFORMATIONAL USE ONLY, AND ARE SUBJECT TO CHANGE AT ANY TIME WITHOUT NOTICE, AND SHOULD NOT BE CONSTRUED AS A COMMITMENT BY ASUS. ASUS ASSUMES NO RESPONSIBILITY OR LIABILITY FOR ANY ERRORS OR INACCURACIES THAT MAY APPEAR IN THIS MANUAL, INCLUDING THE PRODUCTS AND SOFTWARE DESCRIBED IN IT.

Copyright © 2023 ASUSTeK COMPUTER INC. All Rights Reserved.

LIMITATION OF LIABILITY

Circumstances may arise where because of a default on ASUS' part or other liability, you are entitled to recover damages from ASUS. In each such instance, regardless of the basis on which you are entitled to claim damages from ASUS, ASUS is liable for no more than damages for bodily injury (including death) and damage to real property and tangible personal property; or any other actual and direct damages resulted from omission or failure of performing legal duties under this Warranty Statement, up to the listed contract price of each product.

ASUS will only be responsible for or indemnify you for loss, damages or claims based in contract, tort or infringement under this Warranty Statement.

This limit also applies to ASUS' suppliers and its reseller. It is the maximum for which ASUS, its suppliers, and your reseller are collectively responsible.

UNDER NO CIRCUMSTANCES IS ASUS LIABLE FOR ANY OF THE FOLLOWING: (1) THIRD-PARTY CLAIMS AGAINST YOU FOR DAMAGES; (2) LOSS OF, OR DAMAGE TO, YOUR RECORDS OR DATA; OR (3) SPECIAL, INCIDENTAL, OR INDIRECT DAMAGES OR FOR ANY ECONOMIC CONSEQUENTIAL DAMAGES (INCLUDING LOST PROFITS OR SAVINGS), EVEN IF ASUS, ITS SUPPLIERS OR YOUR RESELLER IS INFORMED OF THEIR POSSIBILITY.

SERVICE AND SUPPORT

Visit our multi-language website at <https://www.asus.com/support/>

Contents

| | |
|--------------------------------------|---|
| About this manual..... | 5 |
| Conventions used in this manual..... | 6 |
| Package contents | 7 |

Chapter 1: Getting to know your Embedded Computer

| | |
|---------------------------------|----|
| 1.1 Features | 10 |
| 1.1.1 Front view | 10 |
| 1.1.2 Rear view..... | 13 |
| 1.2 Motherboard Overview | 15 |
| 1.2.1 Motherboard layout..... | 15 |
| 1.2.2 Pico-ITX motherboard..... | 18 |
| 1.2.3 Secondary I/O board..... | 23 |

Chapter 2: Using your Embedded Computer

| | |
|--|----|
| 2.1 Getting started..... | 28 |
| 2.1.1 Connect the AC power adapter to your Embedded Computer | 28 |
| 2.1.2 Connect a display panel to your Embedded Computer | 30 |
| 2.1.3 Connect the USB cable from keyboard or mouse | 31 |
| 2.1.4 Turn on your Embedded Computer | 32 |
| 2.2 Turning off your Embedded Computer..... | 33 |

Chapter 3: Upgrading your Embedded Computer

| | |
|---|----|
| 3.1 Removing the bottom cover | 36 |
| 3.2 Replacing the bottom cover | 37 |
| 3.3 Removing the top cover | 38 |
| 3.4 Replacing the top cover..... | 39 |
| 3.5 Installing a nano SIM card (Front panel) | 40 |
| 3.6 Installing an SD card (Top side)..... | 41 |
| 3.7 Installing a wireless card to the M.2 slot (Top side) | 42 |
| 3.8 Installing an mPCIe / mSATA module (Bottom side) | 44 |
| 3.9 Installing antennas (optional)..... | 47 |
| 3.10 Installing the wall mount | 53 |
| 3.11 Installing DIN rail clips (optional) | 54 |
| 3.12 Installing the terminal block (optional)..... | 55 |

Chapter 4: Setting up your Embedded Computer

| | |
|---------------------------------|----|
| 4.1 Requirements | 58 |
| 4.2 Flashing the OS Image | 58 |

Appendix

| | |
|------------------------------|----|
| Safety information..... | 62 |
| Setting up your system | 62 |
| Care during use..... | 63 |
| Regulatory notices | 65 |
| Service and Support | 78 |

About this manual

This manual provides information about the hardware and software features of your Embedded Computer, organized through the following chapters:

Chapter 1: Getting to know your Embedded Computer

This chapter details the hardware components of your Embedded Computer.

Chapter 2: Using your Embedded Computer

This chapter provides you with information on using your Embedded Computer.

Chapter 3: Upgrading your Embedded Computer

This chapter provides you with information on how to upgrade the memory modules, wireless modules, and hard disk drive / solid state drive of your Embedded Computer.

Chapter 4: Setting up your Embedded Computer

This chapter will guide you in setting up your Embedded Computer for the first time.

Appendix

This section includes notices and safety statements your Embedded Computer.

Conventions used in this manual

To highlight key information in this manual, some text are presented as follows:

IMPORTANT! This message contains vital information that must be followed to complete a task.

NOTE: This message contains additional information and tips that can help complete tasks.

WARNING! This message contains important information that must be followed to keep you safe while performing certain tasks and prevent damage to your Embedded Computer's data and components.

Package contents

Your Embedded Computer package contains the following items:

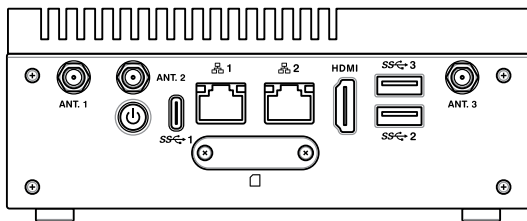

PE100A



AC power adapter*



Power cord*

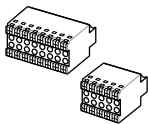

Terminal blocks

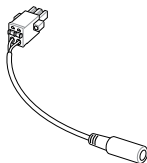

Terminal block power adapter

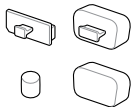

I/O port dust covers

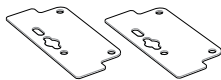

Wall mount kit

Optional items

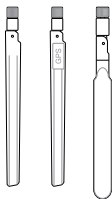

Antennas

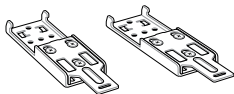

DIN rail clips

NOTE:

- *The bundled power adapter may vary by model and territory.
 - Some bundled accessories may vary depending on model. For details on these accessories, refer to their respective user manuals.
 - The device illustration is for reference only. Actual product specifications may vary depending on model.
 - If the device or its components fail or malfunction during normal and proper use within the warranty period, bring the warranty card to the ASUS Service Center for replacement of the defective components.
-

1

***Getting to know your
Embedded Computer***

1.1 Features

1.1.1 Front view

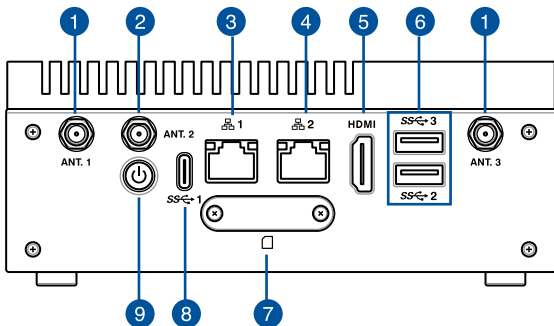

1 ANT. 1 LTE Wireless antenna jack

ANT. 3 The LTE wireless antenna jack allows you to connect a wireless antenna for LTE signals.

NOTE: The LTE wireless antenna is optional and may not come bundled.

2 ANT. 2 GPS Wireless antenna jack

The GPS wireless antenna jack allows you to connect a wireless antenna for GPS signals.

NOTE: The GPS wireless antenna is optional and may not come bundled.

3 1 LAN port

The Realtek® RTL8211 Ethernet controllers with 8-pin RJ-45 LAN port supports a standard Ethernet cable for 10/100/1000 Mbps connection to a local network.

4 2 LAN port

The Intel® I211/I210-AT Gigabit Ethernet controllers with 8-pin RJ-45 LAN port supports a standard Ethernet cable for 10/100/1000 Mbps connection to a local network.

Realtek RTL8211 & Intel I211/I210 LAN port LED indications

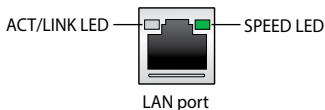

| Activity Link LED | |
|-------------------------------|------------------------------------|
| Status | Description |
| Off | No link |
| Yellow | Linked |
| Yellow (blinking) | Data activity |
| Yellow (blinking then steady) | Ready to wake up from suspend mode |



| Speed LED | |
|-----------|---------------------|
| Status | Description |
| Off | 10 Mbps connection |
| Orange | 100 Mbps connection |
| Green | 1 Gbps connection |

- 5 **HDMI** **HDMI™ port**
The integrated 19-pin HDMI™ (High Definition Multimedia Interface) 2.0 port with a receptacle connector can support resolutions up to 3840 x 2160 @ 60 Hz on external display devices.

- 6  **USB 3.2 Gen 1 port**
The USB 3.2 Gen 1 (Universal Serial Bus) port provides a transfer rate up to 5 Gbit/s and a maximum of 5V/0.9A output per port.

- 7  **Nano SIM card slot with metal cover**
The hot-swappable nano SIM slot is located on the front panel for easy access.

NOTE: This slot is covered with a metal cover. Ensure to remove and replace the metal cover when installing a nano SIM card. For more information on removing and replacing the metal cover, refer to **Installing a nano SIM card**.

- 8  **USB 3.2 Gen 1 Type-C® port**
 This USB Type-C® (Universal Serial Bus) port provides a transfer rate of up to 5 Gbit/s and a maximum of 5V/1.5A output. This port supports OTG (On-The-Go) mode that can allow to act as a device for flashing OS image via host PC.

- 9  **Power button**
The power button allows you to turn the Embedded Computer on or off with a single press. To force your Embedded Computer to shutdown, press and hold the power button for ten (10) seconds.

1.1.2 Rear view

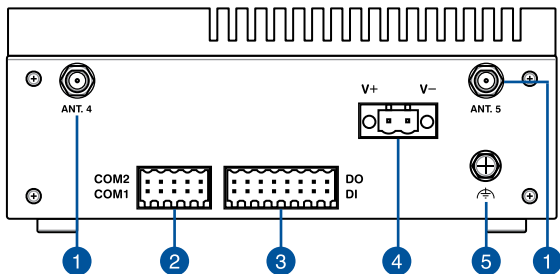

1 ANT.4 WLAN wireless antenna jack

ANT.5 The WLAN antenna jack allows to connect a wireless antenna to enhance Wi-Fi signals.

2 COM2 Serial (COM) terminal connector

COM1

The 10-pin Serial (COM) terminal connector can support 1 x RS-232/422/485 and 1 x RS-232/CAN Bus (optional) COM headers and allows you to connect devices that have serial ports, such as bar code scanner, modem, and printers. Please refer to the illustrations below for the pin definition of the Serial (COM) terminal connector.

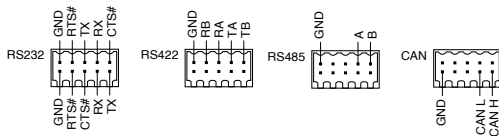

3 DO DI **Isolated DIO connector**

The Isolated Digital Input/Output (DIO) connector provides electrical isolation (up to 2500 VDC) of digital input and output signals, which allow micro controllers to detect and output logic states. The high voltage protection can be used in industrial level uses. Please refer to the illustration below for the Isolated DIO connector's pin definitions.

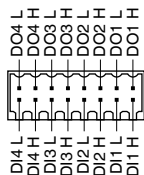

| Signal | Specifications | |
|--------|-----------------------|-----------|
| DO | Output voltage range | 0~24 VDC |
| | Rated output current | 1A |
| DI | Voltage for logic "0" | 0~0.8 VDC |
| | Voltage for logic "1" | 5~24 VDC |
| | Rated input current | ±50 mA |

4 **Power input**

The supplied terminal block power adapter converts AC power to DC power for use with this jack. Power supplied through this jack supplies power to the Embedded Computer.

WARNING! The power adapter may become warm to hot when in use. Do not cover the adapter and keep it away from your body.

5 **Functional Earth Ground**

The Functional Earth Ground provides you with a grounding point.

1.2 Motherboard Overview

1.2.1 Motherboard layout

The PE100A is an Embedded Computer based on a Pico-ITX motherboard and is supported by a secondary I/O board for extra functionality. Refer to the table for the page numbers of the numbered items.

Pico-ITX motherboard

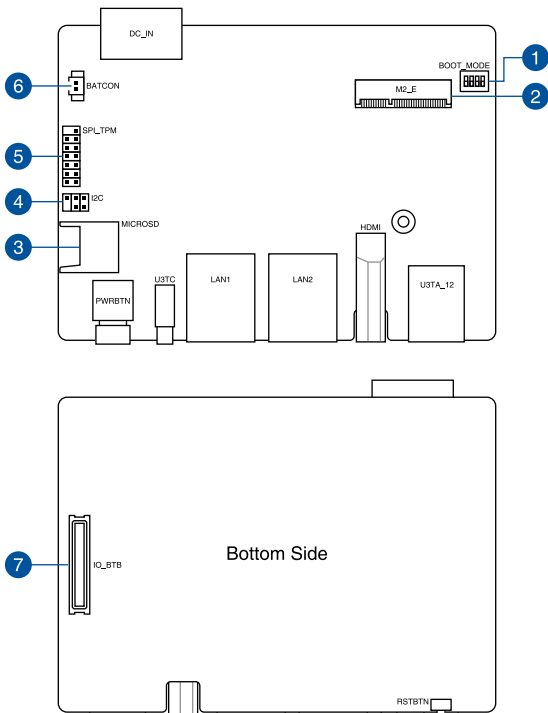

Secondary I/O board

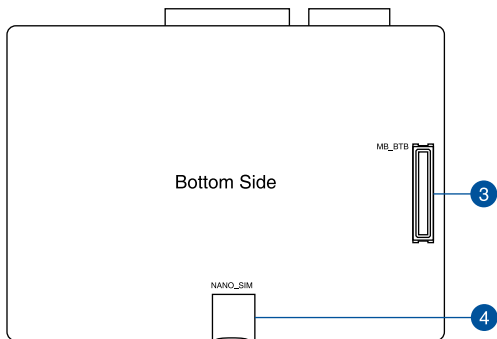
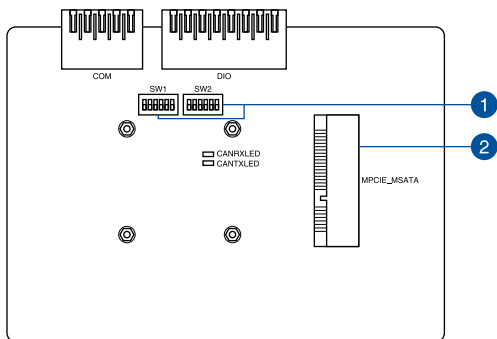

| Layout contents | | Page |
|-----------------------------|--------------------------------------|-------------|
| Pico-ITX motherboard | | |
| 1. | Boot Mode switch | 18 |
| 2. | M.2 Wi-Fi slot | 19 |
| 3. | Micro SD card slot | 19 |
| 4. | I2C connector | 20 |
| 5. | SPI TPM connector | 20 |
| 6. | RTC Battery connector | 21 |
| 7. | IO Board-to-Board connector | 22 |
| Secondary I/O board | | |
| 1. | IO board switch | 23 |
| 2. | mPCIe / mSATA slot | 24 |
| 3. | Motherboard Board-to-Board connector | 25 |
| 4. | Nano SIM Card slot | 26 |

1.2.2 Pico-ITX motherboard

1. Boot Mode switch

The Boot Mode switch allows you to configure between different boot modes and the location to boot from. Please refer to the table below for the different boot modes.

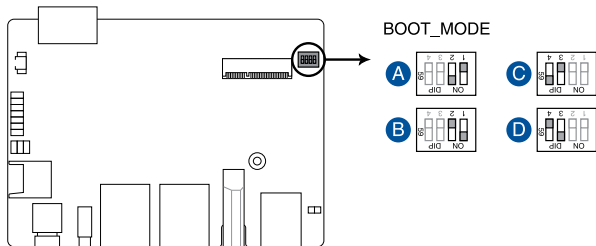

| Boot Mode | | Boot type | |
|-----------|-----|-----------|-------------------------|
| | 1 | 2 | |
| A | OFF | ON | Serial Downloader |
| B | ON | OFF | Internal Boot (default) |
| Boot Mode | | Boot type | |
| | 3 | 4 | |
| C | OFF | ON | eMMC (default) |
| D | ON | OFF | SD |

2. M.2 Wi-Fi slot

The M.2 Wi-Fi slot allows you to install an M.2 Wi-Fi module (E-key, type 2230).

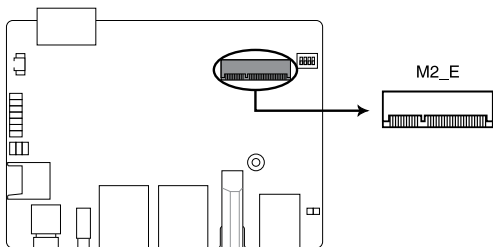

NOTE: The M.2 Wi-Fi module is purchased separately.

3. Micro SD Card slot

The micro SD Card slot allows you to install a micro SD card.

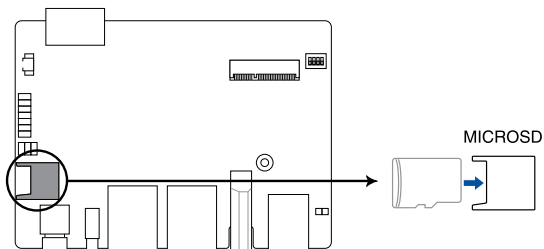

NOTE: The micro SD card is purchased separately.

4. I2C connector

The I2C (Inter-Integrated Circuit) connector allows you to connect an I2C compatible device.

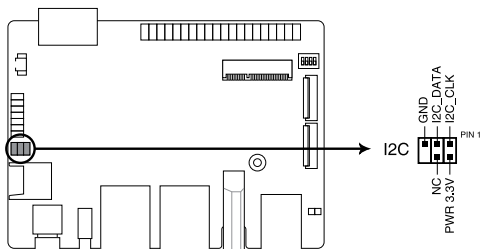

Connector type

Header 2x3p, K6, 2.0mm pitch

5. SPI TPM connector

The SPI TPM connector supports a Trusted Platform Module (TPM) system, which can securely store keys, digital certificates, passwords, and data. A TPM system also helps enhance network security, protects digital identities, and ensures platform integrity.

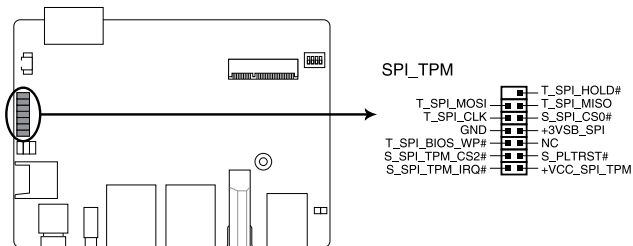

Connector type

Header 2x7p, K14, 2.0mm pitch

6. RTC Battery connector

The RTC Battery connector allows you to connect a lithium CMOS battery.

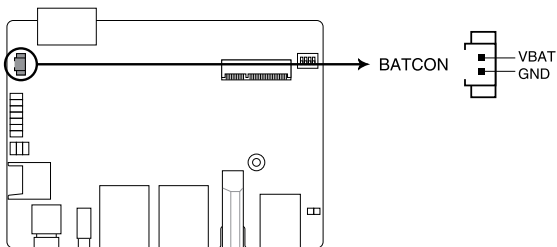

7. IO Board-to-Board connector

The IO Board-to-Board connector allows you to connect the Pico-ITX motherboard and secondary I/O board.

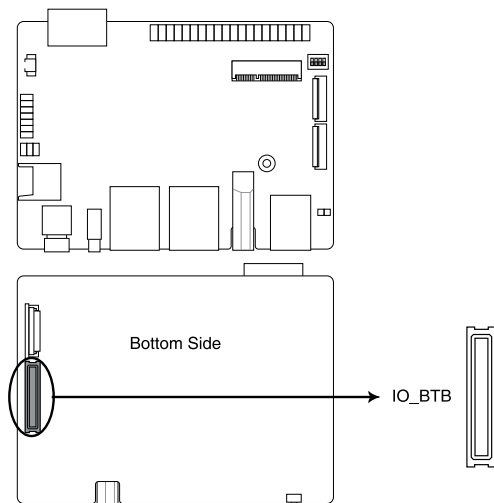

1.2.3 Secondary I/O board

1. IO board switch

The IO Board switch allows you to configure between different configurations for the onboard slots and ports. Refer to the tables below for the different switch configurations.

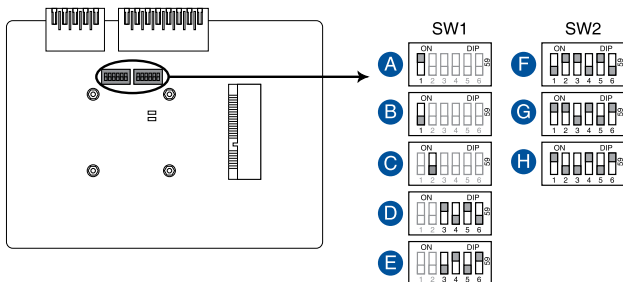

SW1

| mPCIe / mSATA | | Output type |
|---------------|-----|-----------------|
| | 1 | |
| A | ON | mPCIe (default) |
| B | OFF | mSATA |

| Terminator | |
|------------|---------------|
| | 2 |
| C | OFF (default) |

| Terminator | | | | | Output type |
|------------|-----|-----|-----|-----|--------------------|
| | 3 | 4 | 5 | 6 | |
| D | ON | OFF | ON | OFF | RS-232 (default) |
| E | OFF | ON | OFF | ON | CAN Bus (optional) |

SW2

| Terminator | | | | | | Output type | |
|------------|-----|-----|-----|-----|-----|-------------|------------------|
| | 1 | 2 | 3 | 4 | 5 | | 6 |
| F | OFF | ON | ON | OFF | ON | OFF | RS-232 (default) |
| G | ON | ON | OFF | ON | OFF | ON | RS-422 |
| H | ON | OFF | OFF | ON | OFF | ON | RS-485 |

2. mPCIe / mSATA slot

The mPCIe/mSATA slot allows you to install an mPCIe peripheral device or an mSATA peripheral device. The default setting for the slot is mPCIe. To switch to mSATA, please refer to **IO board switch**.

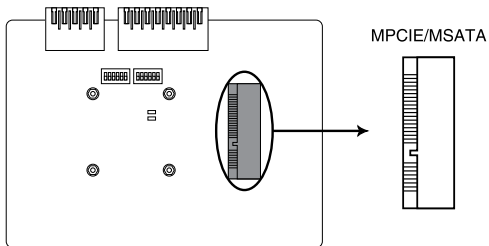

NOTE: The mPCIe / mSATA peripheral device is purchased separately.

3. Motherboard Board-to-Board connector

The Motherboard Board-to-Board connector allows you to connect the Pico-ITX motherboard and secondary I/O board.

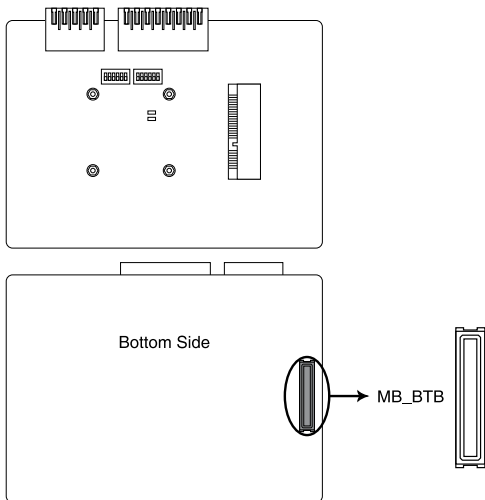

4. Nano SIM Card slot

The nano SIM card slot allows you to install a nano SIM card.

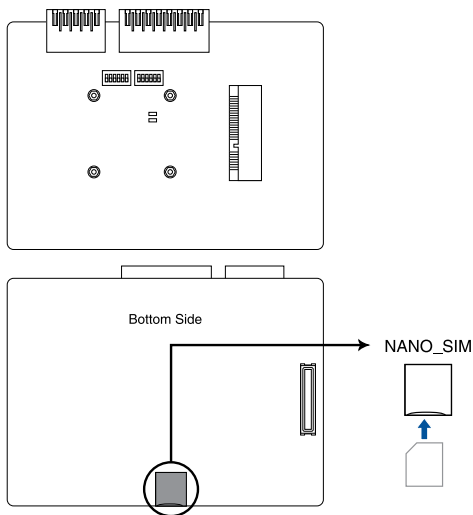

NOTE: The nano SIM card is purchased separately.

2

Using your Embedded Computer

2.1 Getting started

2.1.1 Connect the AC power adapter to your Embedded Computer

To connect the AC power adapter to your Embedded Computer:

- Connect the power cord to the AC power adapter.
- Connect the AC power adapter to the terminal block power adapter.
- Connect the 2-pin terminal block DC power connector into your Embedded Computer's power (DC) input.
- Plug the AC power adapter into a 100V~240 V power source.

NOTE: The power adapter may vary in appearance, depending on model and your region.

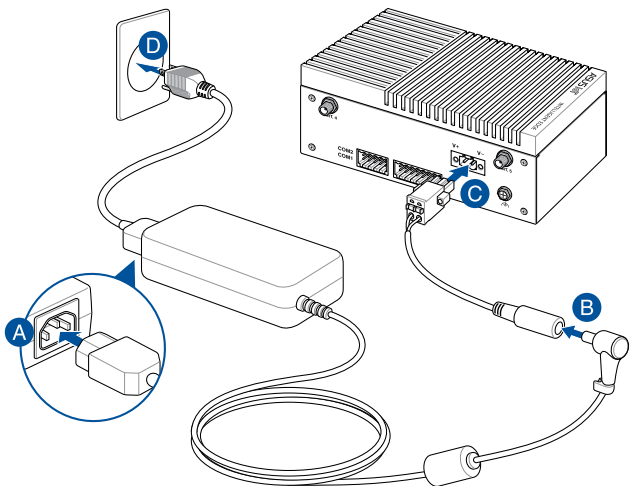

IMPORTANT!

- We strongly recommend that you use only the AC power adapter and cable that came with your Embedded Computer.
 - We strongly recommend that you use a grounded wall socket while using your Embedded Computer.
 - The socket outlet must be easily accessible and near your Embedded Computer.
 - To disconnect your Embedded Computer from its main power supply, unplug your Embedded Computer from the power socket.
-

NOTE:

Refer to the following for power adapter and system power requirements:

65W Power adapter

- Input voltage: 100-240 Vac
- Input frequency: 50-60 Hz
- Rated output current: 5.41 A / 3.42 A (65.0 W)
- Rated output voltage: 12-19 Vdc

System

- Rated voltage: 19 Vdc; rated current: 3.42 A
 - Rated voltage: 12 Vdc; rated current: 5.41 A
 - Rated voltage: 12-24 Vdc; rated current: 5.41 A-2.7 A
-

WARNING!

- Do not use power adapters or batteries from other devices to reduce the risk of injury to persons due to fire or explosion. Use only UL certified power adapters or batteries supplied by the manufacturer or authorized retailers.
 - Do not disable or remove the power cord grounding plug, the grounding is an important safety feature.
 - Ensure to plug the power cord into a grounded (earthed) electrical outlet that is easily accessible at all times.
-

2.1.2 Connect a display panel to your Embedded Computer

You can connect a display panel or projector to your Embedded Computer that has the following connector(s):

- HDMI™ connector

To connect a display panel to your Embedded Computer:

Connect one end of an HDMI™ cable to an external display, and the other end of the cable to your Embedded Computer's HDMI™ port.

Connect display via HDMI™ port

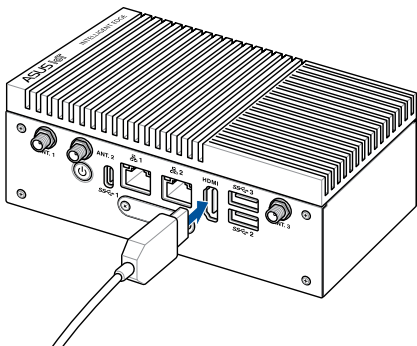

2.1.3 Connect the USB cable from keyboard or mouse

You can connect generally any USB keyboard and mouse to your Embedded Computer. You can also connect a USB dongle for a wireless keyboard and mouse set.

To connect a keyboard and mouse to your Embedded Computer:

Connect the USB cable from your keyboard and mouse to any of the USB ports of your Embedded Computer.

NOTE:

- The keyboard varies with country and/or region.
 - The keyboard and mouse are purchased separately.
-

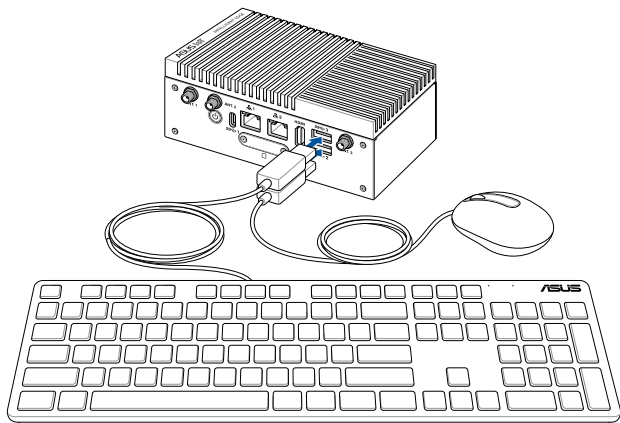

2.1.4 Turn on your Embedded Computer

Press the power button to turn on your Embedded Computer.

NOTE: The Embedded Computer will power on automatically the first time it is connected to a power source.

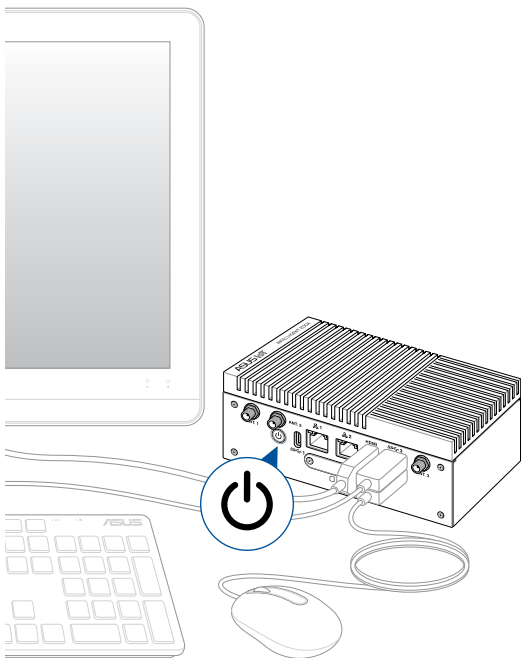

2.2 Turning off your Embedded Computer

If your Embedded Computer is unresponsive, press and hold the power button for at least ten (10) seconds until your Embedded Computer turns off.

3

Upgrading your Embedded Computer

IMPORTANT!

- Ensure that your hands are dry before proceeding with the rest of the installation process. Before installing any of the features in this guide, use a grounded wrist strap or touch a safely grounded object or metal object to avoid damaging them due to static electricity.
 - Turn off the power of your Embedded Computer and allow it to cool for at least 10 minutes before performing any installation/uninstallation process.
-

NOTE: The illustrations in this section are for reference only. The slots may vary depending on model.

3.1 Removing the bottom cover

1. Turn off your Embedded Computer, and then disconnect all cables and peripherals.
2. Place the Embedded Computer on a flat stable surface with its top side facing down.
3. Remove the screw from the bottom cover (A), then remove the bottom cover (B).

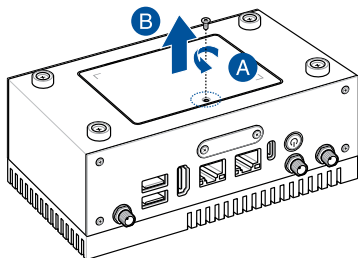

3.2 Replacing the bottom cover

1. Align the bottom cover latches with the latch holes on the bottom of your Embedded Computer.

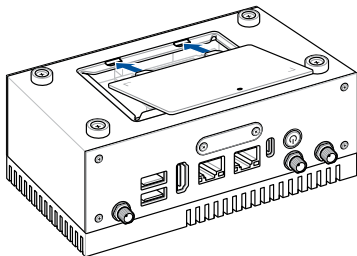

2. Secure the bottom cover using the screw removed previously.

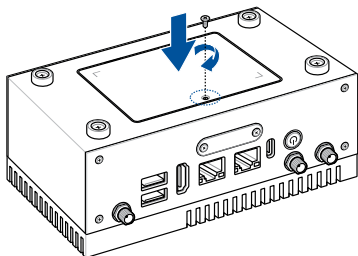

3.3 Removing the top cover

1. Turn off your Embedded Computer, and then disconnect all cables and peripherals.
2. Remove the four (4) rubber feet screws from the bottom of the Embedded Computer (A), and then remove the top cover (B).

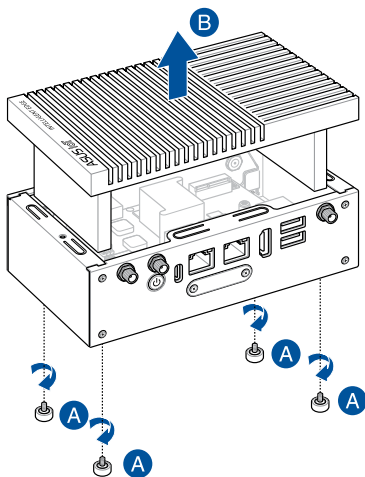

3.4 Replacing the top cover

1. Place the top cover into the Embedded Computer chassis and ensure the ASUS IoT logo is on the left side of the top cover when you are facing the front of the Embedded Computer.

IMPORTANT! Ensure that the RF cables and/or other cables are not under or in the way of the top cover when installing it, as this may cause the antennas to not work properly.

2. Secure the top cover from the bottom of the Embedded Computer using the four (4) rubber feet screws removed previously.

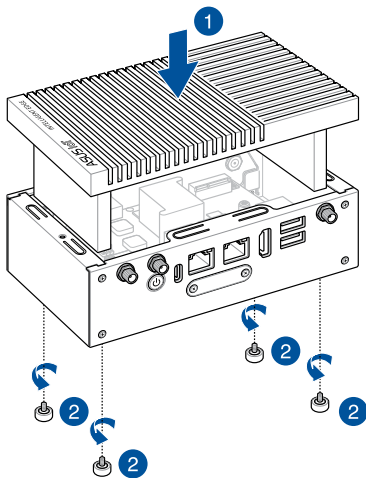

3.5 Installing a nano SIM card (Front panel)

NOTE: This Nano SIM slot is hot swappable.

1. Remove the two (2) screws securing the Nano SIM card slot cover, and then remove the cover.

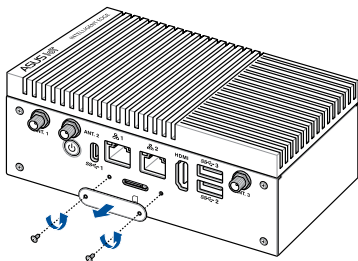

2. Insert the nano SIM card into the slot.
3. Replace slot cover and secure it with the screws removed previously.

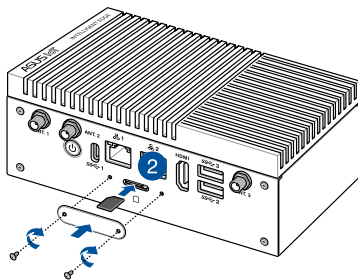

3.6 Installing an SD card (Top side)

Insert your SD card into the SD card slot. Ensure that the SD card is pushed all the way into the SD card slot.

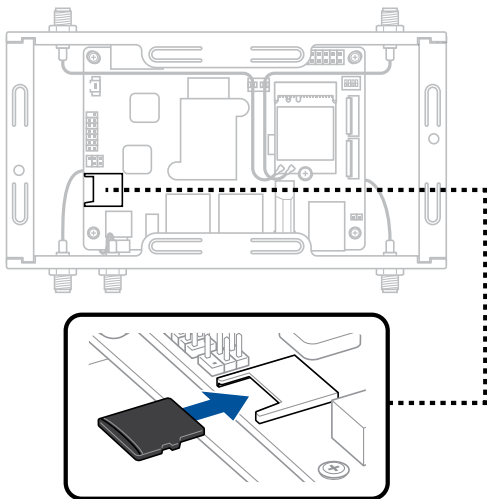

3.7 Installing a wireless card to the M.2 slot (Top side)

1. Remove the M.2 stand screw.
2. Align and insert the wireless card into its slot inside the Embedded Computer.
3. Gently push down the wireless card on top of the screw hole, and then fasten it using the previously removed stand screw.
4. (optional) Connect the RF cables from the antennas to your wireless card. Ensure that the correct cable is attached to each of the connectors by following the color coding chart on the next page.
5. (optional) Use the cable clip to organize the cables.

NOTE:

- Please refer to the **Installing antennas** section for more information on installing the antennas.
 - Connecting antennas to your wireless card may strengthen the wireless signal.
 - A soft clicking sound indicates that the antenna has been securely attached on the wireless card.
-

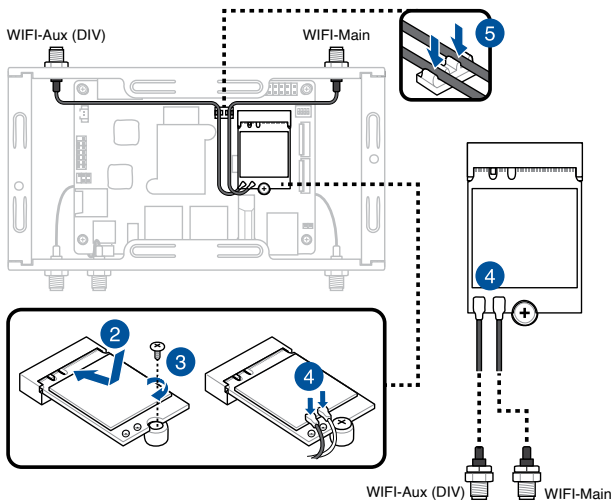

| Antenna Color Coding | |
|----------------------|----------------|
| Band Color | Antenna Type |
| Black | WIFI-Aux (DIV) |
| Black | WIFI-Main |

3.8 Installing an mPCIe / mSATA module (Bottom side)

Your Embedded Computer comes with an mPCIe / mSATA slot that allows you to install an LTE mPCIe module, mPCIe Coral TPU module, or mSATA storage module.

To install an LTE mPCIe module:

1. Remove the two (2) standoff screws
2. Align and insert the LTE module into the slot.
3. Press down, and then secure it in place using the two (2) screws previously removed.
4. (optional) Connect the RF cables from the antennas to your LTE module. Ensure that the correct cable is attached to each of the connectors by following the color coding chart on the next page.
5. (optional) Use the cable clip to organize the cables.

NOTE:

- To enable the hot-plug function of your LTE module, click the **weston-terminal** icon in the upper left corner of your screen, and type the first command below when prompted:

```
mm_cli sim-detect 1      (enable hot-plug function)
mm_cli sim-detect 0      (disable hot-plug function)
mm_cli sim-detect        (display current setting)
```

- Refer to **Installing antennas** for more information on installing the antennas.
 - Connecting antennas to your LTE module may strengthen the signal.
 - A soft clicking sound indicates that the antenna has been securely attached on the LTE module.
-

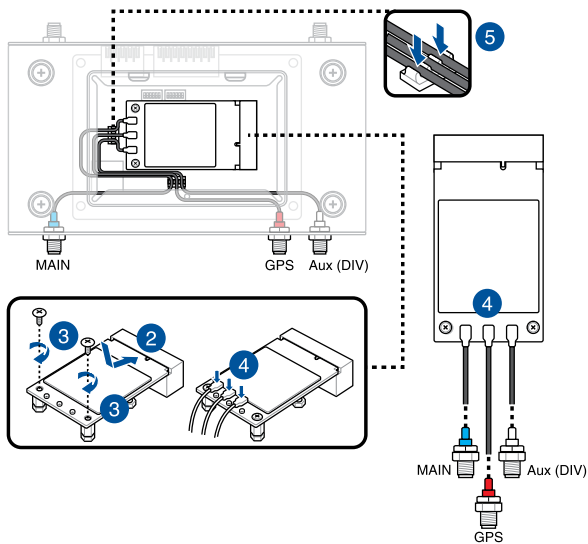

Antenna Color Coding

| Band Color | Antenna Type |
|------------|---------------|
| White | LTE-Aux (DIV) |
| Blue | LTE-Main |
| Red | GPS |

To install an mPCIe TPU module:

1. Align and insert the mPCIe TPU module into the slot.
2. Press down, and then secure it in place using the two (2) screws bundled with the module.

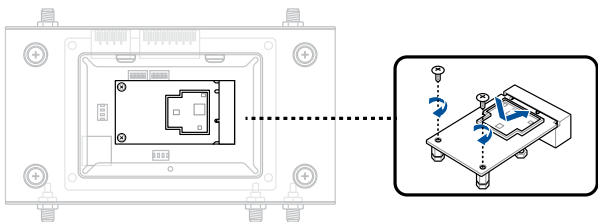

To install an mSATA storage module:

1. Align and insert the mSATA storage module into the slot.
2. Press down, and then secure it in place using the two (2) screws bundled with the module.

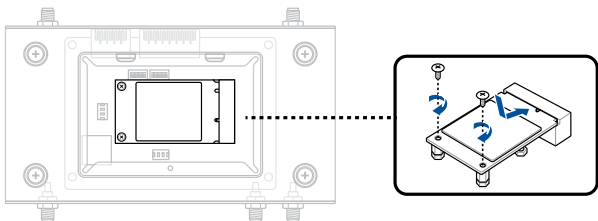

3.9 Installing antennas (optional)

You may install antennas to the five (5) antenna jacks located on the front and rear panels. The installed antennas can be connected to an LTE card installed in the Mini PCIe/mSATA slot (bottom side) or to a wireless card installed in the M.2 Wi-Fi slot (top side).

NOTE:

- It is recommended that you install the antennas connected to the LTE card to the front panel and the antennas connected to the wireless card to the rear panel (see below diagram).
 - LTE antennas are flatter and slightly longer than the Wi-Fi and GPS antennas.
 - GPS antennas look the same as Wi-Fi antennas but are clearly labeled as GPS.
-

Antenna jack locations

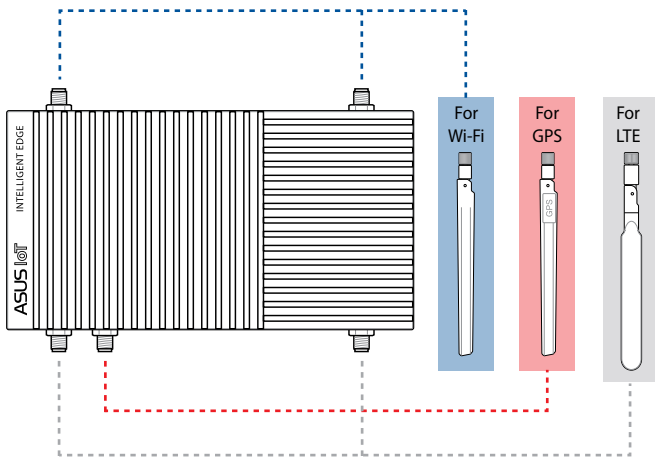

Installing wireless card antennas

NOTE: If your Embedded Computer came pre-installed with wireless card antenna jacks, skip to step 9.

1. Remove the rear panel cover by removing the four (4) screws from the cover.

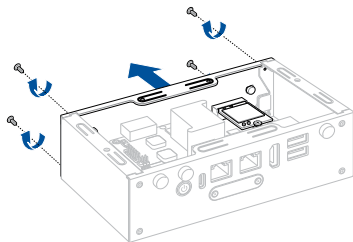

2. Prepare the RF connector and cable.
3. Remove the rubber caps from the antenna holes.
4. Insert the antenna jack end of the RF connector and cable into the antenna jack from within the chassis outwards.

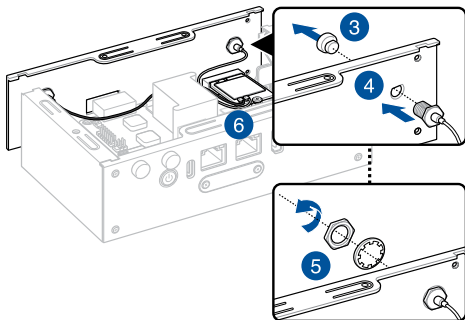

5. Insert the bundled O-ring to the antenna jack, then secure the antenna jack using bundled hex screw.
6. Connect the other end of the RF connector and cable to your wireless card. Refer to **Installing a wireless card to the M.2 slot (Top side)** for details.
7. Replace the rear panel cover, and secure it using the four (4) screws previously removed.

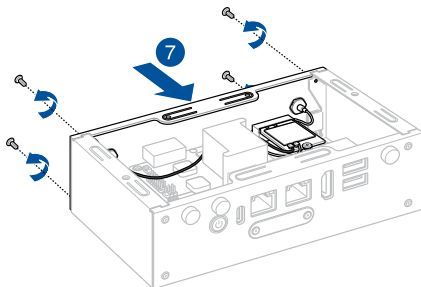

8. Replace the top cover. Refer to **Replacing the top cover** for details.
9. Screw the external Wi-Fi antennas onto their corresponding antenna jacks on the rear panel by turning them in a clockwise direction.
10. Position the antennas for optimal signal reception.

Installing LTE and GPS antennas

NOTE: If your Embedded Computer came pre-installed with LTE and GPS antenna jacks, skip to step 10.

1. Remove the front panel cover by removing the four (4) screws from the cover.

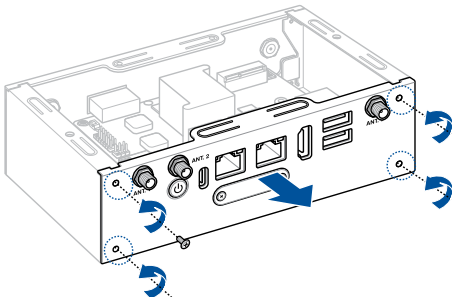

2. Prepare the RF connectors and cables.
3. Remove the rubber caps from the antenna holes.
4. Insert the antenna jack end of the RF connectors and cables into the antenna jacks from within the chassis outwards.
5. Insert the bundled O-rings over the antenna jacks, and then secure the antenna jacks using the bundled hex screws.
6. Thread the cables from both sides of the motherboard to the bottom of the device.

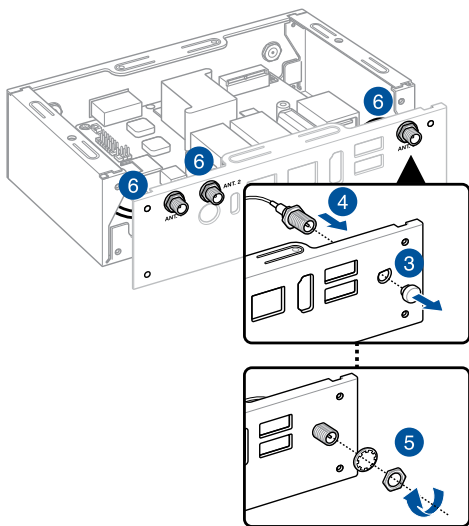

7. Connect the other end of the RF connectors and cables to your WLAN card. Refer to **Installing an mPCIe module to the Mini PCIe/mSATA slot (Bottom side)** for details.

8. Replace the front panel, and then secure it using the four (4) screws previously removed.

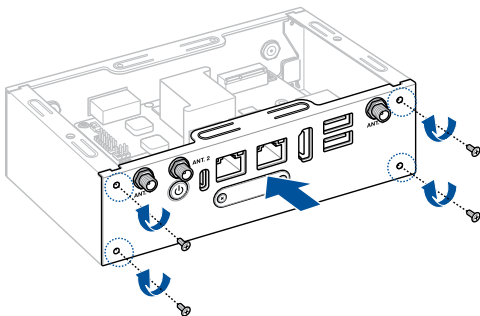

9. Replace the top and bottom covers. Refer to **Replacing the top cover** and **Replacing the bottom cover** for details.
10. Screw the external LTE and GPS antennas onto their corresponding antenna jacks on the front panel by turning them in a clockwise direction.
11. Position the antennas for optimal signal reception.

3.10 Installing the wall mount

1. Remove the four (4) rubber feet screws.

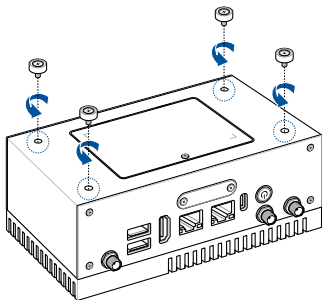

2. Align the wall mount with the rubber feet screw holes, then remove the rubber feet from the rubber feet screws and secure the wall mount to your Embedded Computer using the rubber feet screws.

NOTE: The rubber feet screws and wall mount screws are the same screws.

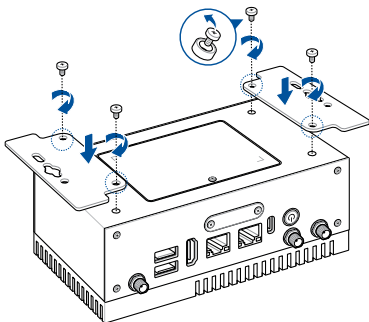

3.11 Installing DIN rail clips (optional)

1. Make sure that the wall mount is already installed. Refer to the section **Installing the wall mount** for installation instructions.
2. Align the screw holes on the DIN rail clips to the ones on the wall mount as shown below.

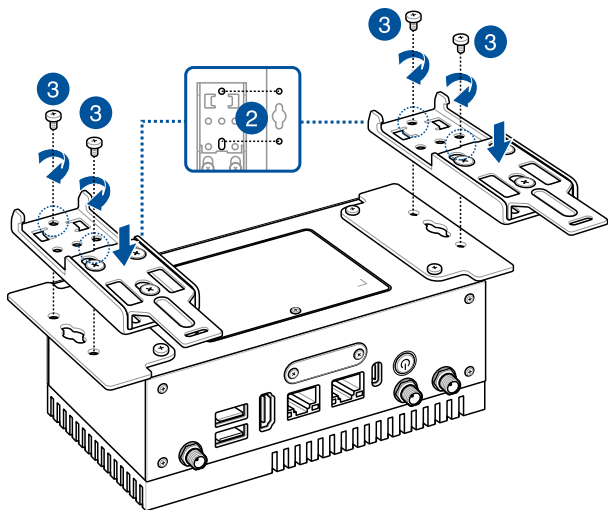

3. Secure the DIN rail clips to the wall mount using the screws bundled with the DIN rail clips.
4. Clip the final assembly to a DIN rail by hooking the DIN rail clips to the top of the DIN rail and then pressing down until you hear the clips snap into place.

3.12 Installing the terminal block (optional)

You may install terminal blocks into the **Serial (COM) terminal connector** and **Isolated DIO connector**, which allow you to support additional devices with serial ports or micro controllers by referring to the pin definitions and connecting cables to the slots on the terminal blocks as needed.

IMPORTANT! Connect only one (1) cable to a slot on the terminal block.

NOTE:

- The terminal block is purchased separately.
 - Please refer to **Rear view** for the location and pin definitions of the **Serial (COM) terminal connector** and **Isolated DIO connector**.
-

Installing a terminal block to the Serial (COM) terminal connector

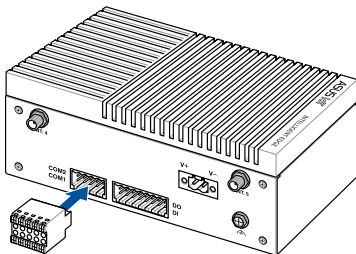

Installing a terminal block to the Isolated DIO connector

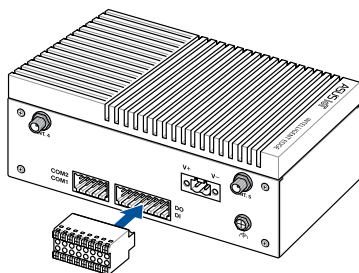

4

Setting up your Embedded Computer

4.1 Requirements

Before you start setting up your Embedded Computer, make sure you have the following available:

- 1 x USB Type-C® cable with data transfer function
(to connect your PC to your Embedded Computer's data port)
- 1 x Power supply
- 1 x Monitor with HDMI™ cable
- 1 x Keyboard and Mouse set

NOTE: Ensure to use the bundled power supply, or, if you are using another power supply, ensure to use a 12~24V power supply.

4.2 Flashing the OS Image

Before you begin the flashing procedure, please ensure of the following:

- Your Embedded Computer is completely powered off, and the power cord and cables connecting your Embedded Computer to your computer are all disconnected.
- The Boot Mode switch is set to eMMC mode, refer to **Boot Mode switch** under the **Pico-ITX motherboard** section for more information on setting the Boot Mode switch.

Initiating Fastboot mode:

1. Connect the USB Type-C® cable to the USB Type-C® ports on your Embedded Computer and host computer.
2. Power on your Embedded Computer, you should automatically be booted into Fastboot mode.

NOTE:

- Please note that you will only be booted into Fastboot mode when booting up your Embedded Computer for the first time.
 - Please refer to the readme file in the unzipped image folder for details on other items, such as re-flash or recovery.
-

Executing the flash script:

1. Download the OS image from the ASUS website, and then unzip the image file.
2. Run the flash script or command file to start the flash process. The flash process should take a few minutes. Once the flash is completed, your Embedded Computer will reboot and you should be booted to the terminal prompt.

NOTE: Please refer to the readme file in the unzipped image folder for troubleshooting steps.



Appendix

Safety information

Your Embedded Computer is designed and tested to meet the latest standards of safety for information technology equipment. However, to ensure your safety, it is important that you read the following safety instructions.

Setting up your system

- Read and follow all instructions in the documentation before you operate your system.
- Do not use this product near water or a heated source.
- Set up the system on a stable surface.
- Peripherals with extended tolerance (such as industrial grade mSATA, and micro SD card) will allow this product to be used in environments with ambient temperatures between -20°C and 60°C, with a 0.1m/s air flow.
- The product should be used in environments with an ambient temperature of 60°C when using the 65W adapter.
- If you use an extension cord, make sure that the total ampere rating of the devices plugged into the extension cord does not exceed its ampere rating.
- This equipment should be installed and operated with a minimum distance of 20cm between the radiator and your body.
- Restricted Access Location:

The equipment should only be installed in a Restricted Access Area where both these conditions apply:

- access can only be gained by USERS who have been instructed about the reasons for the restrictions applied to the location and about any precautions that shall be taken; and
 - access is through the use of a TOOL or lock and key, or other means of security, and is controlled by the authority responsible for the location.
- This device shall not be connected to an Ethernet network with outside plant routing.

Care during use

- Do not walk on the power cord or allow anything to rest on it.
- Do not spill water or any other liquids on your system.
- When the system is turned off, a small amount of electrical current still flows. Always unplug the power cord from the power outlets before cleaning the system.
- Use this product with care when operating at full load, as the product may reach temperatures of up to 60°C and the outer casing may reach temperatures of up to 73°C.
- If you encounter the following technical problems with the product, unplug the power cord and contact a qualified service technician or your retailer.
 - The power cord or plug is damaged.
 - Liquid has been spilled into the system.
 - The system does not function properly even if you follow the operating instructions.
 - The system was dropped or the cabinet is damaged.
 - The system performance changes.

Safety Precautions

Accessories that came with this product have been designed and verified for the use in connection with this product. Never use accessories for other products to prevent the risk of electric shock or fire.

Lithium-Ion Battery Warning

CAUTION: Danger of explosion if battery is incorrectly replaced. Replace only with the same or equivalent type recommended by the manufacturer. Dispose of used batteries according to the manufacturer's instructions.

NO DISASSEMBLY

The warranty does not apply to the products that have been disassembled by users



DO NOT throw the Embedded Computer in municipal waste. This product has been designed to enable proper reuse of parts and recycling. This symbol of the crossed out wheeled bin indicates that the product (electrical, electronic equipment, and mercury-containing button cell battery) should not be placed in municipal waste. Check local technical support services for product recycling.

Regulatory notices

COATING NOTICE

IMPORTANT! To provide electrical insulation and maintain electrical safety, a coating is applied to insulate the device except on the areas where the I/O ports are located.

Federal Communications Commission Statement

This device complies with Part 15 of the FCC Rules. Operation is subject to the following two conditions:

- This device may not cause harmful interference, and
- This device must accept any interference received including interference that may cause undesired operation.

This equipment has been tested and found to comply with the limits for a Class A digital device, pursuant to part 15 of the FCC Rules. These limits are designed to provide reasonable protection against harmful interference when the equipment is operated in a commercial environment.

This equipment generates, uses, and can radiate radio frequency energy and, if not installed and used in accordance with the instruction manual, may cause harmful interference to radio communications. Operation of this equipment in a residential area is likely to cause harmful interference in which case the user will be required to correct the interference at his own expense.

IMPORTANT! Outdoor operations in the 5.15~5.25 GHz band is prohibited. This device has no Ad-hoc capability for 5250~5350 and 5470~5725 MHz.

CAUTION! Any changes or modifications not expressly approved by the grantee of this device could void the user's authority to operate the equipment.

RF exposure warning

This equipment must be installed and operated in accordance with provided instructions and the antenna(s) used for this transmitter must be installed to provide a separation distance of at least 20 cm from all persons and must not be co-located or operating in conjunction with any other antenna or transmitter. End-users and installers must be provide with antenna installation instructions and transmitter operating conditions for satisfying RF exposure compliance.

End Product Labeling

This transmitter module is authorized only for use in device where the antenna may be installed such that 20cm may be maintained between the antenna and users. The final end product must be labeled in a visible area with the following:

Contains FCC ID: TX2-RTL8822CE and Contains IC:6317A-RTL8822CE

ISED Radiation Exposure Statement for Canada

This equipment complies with ISED radiation exposure limits set forth for an uncontrolled environment. To maintain compliance with ISED RF exposure compliance requirements, please avoid direct contact to the transmitting antenna during transmitting. End users must follow the specific operating instructions for satisfying RF exposure compliance.

Operation is subject to the following two conditions:

- This device may not cause interference and
- This device must accept any interference, including interference that may cause undesired operation of the device.

Compliance Statement of Innovation, Science and Economic Development Canada (ISED)

This device complies with Innovation, Science and Economic Development Canada licence exempt RSS standard(s). Operation is subject to the following two conditions: (1) this device may not cause interference, and (2) this device must accept any interference, including interference that may cause undesired operation of the device.

CAN ICES-003(A)/NMB-003(A)

Déclaration de conformité de Innovation, Sciences et Développement économique Canada (ISED)

Le présent appareil est conforme aux CNR d'Innovation, Sciences et Développement économique Canada applicables aux appareils radio exempts de licence. L'exploitation est autorisée aux deux conditions suivantes : (1) l'appareil ne doit pas produire de brouillage, et (2) l'utilisateur de l'appareil doit accepter tout brouillage radioélectrique subi, même si le brouillage est susceptible d'en compromettre le fonctionnement.

CAN ICES-003(A)/NMB-003(A)

Wireless Operation Channel for Different Domains

| | | |
|-------------|-----------------|-------------------|
| N. America | 2.412-2.462 GHz | Ch01 through CH11 |
| Japan | 2.412-2.484 GHz | Ch01 through Ch14 |
| Europe ETSI | 2.412-2.472 GHz | Ch01 through Ch13 |

KC: Korea Warning Statement

Class A:

사용자 안내문

이 기기는 업무용 환경에서 사용할 목적으로 적합성평가를 받은 기기로서 가정용 환경에서 사용하는 경우 전파간섭의 우려가 있습니다.

VCCI: Japan Compliance Statement

Class A ITE

この装置は、クラスA機器です。この装置を住宅環境で使用すると電波妨害を引き起こすことがあります。この場合には使用者が適切な対策を講ずるよう要求されることがあります。

VCCI - A

Japan RF Equipment Statement

屋外での使用について

本製品は、5GHz帯域での通信に対応しています。電波法の定めにより5.2GHz、5.3GHz帯域の電波は屋外で使用が禁じられています。

法律および規制遵守

本製品は電波法及びこれに基づく命令の定めるところに従い使用してください。日本国外では、その国の法律または規制により、本製品の使用ができないことがあります。このような国では、本製品を運用した結果、罰せられることがあります。当社は一切責任を負いかねますのでご了承ください。

Japan JATE

本製品は電気通信事業者（移動通信会社、固定通信会社、インターネットプロバイダ等）の通信回線（公衆無線LANを含む）に直接接続することができません。本製品をインターネットに接続する場合は、必ずルーター等を経由し接続してください。

Declaration of compliance for product environmental regulation

ASUS follows the green design concept to design and manufacture our products, and makes sure that each stage of the product life cycle of ASUS product is in line with global environmental regulations. In addition, ASUS disclose the relevant information based on regulation requirements.

Please refer to <http://csr.asus.com/Compliance.htm> for information disclosure based on regulation requirements ASUS is complied with:

EU REACH and Article 33

Complying with the REACH (Registration, Evaluation, Authorization, and Restriction of Chemicals) regulatory framework, we publish the chemical substances in our products at ASUS REACH website at

<http://csr.asus.com/english/REACH.htm>

EU RoHS

This product complies with the EU RoHS Directive. For more details, see

<http://csr.asus.com/english/article.aspx?id=35>

Japan JIS-C-0950 Material Declarations

Information on Japan RoHS (JIS-C-0950) chemical disclosures is available on

<http://csr.asus.com/english/article.aspx?id=19>

India RoHS

This product complies with the “India E-Waste (Management) Rules, 2016” and prohibits use of lead, mercury, hexavalent chromium, polybrominated biphenyls (PBBs) and polybrominated diphenyl ethers (PBDEs) in concentrations exceeding 0.1% by weight in homogenous materials and 0.01% by weight in homogenous materials for cadmium, except for the exemptions listed in Schedule II of the Rule.

Vietnam RoHS

ASUS products sold in Vietnam, on or after September 23, 2011, meet the requirements of the Vietnam Circular 30/2011/TT-BCT.

Các sản phẩm ASUS bán tại Việt Nam, vào ngày 23 tháng 9 năm 2011 trở về sau, đều phải đáp ứng các yêu cầu của Thông tư 30/2011/TT-BCT của Việt Nam.

Turkey RoHS

AEEE Yönetmeliğine Uygundur

ASUS Recycling/Takeback Services

ASUS recycling and takeback programs come from our commitment to the highest standards for protecting our environment. We believe in providing solutions for you to be able to responsibly recycle our products, batteries, other components as well as the packaging materials. Please go to <http://csr.asus.com/english/Takeback.htm> for detailed recycling information in different regions.

Ecodesign Directive

European Union announced a framework for the setting of ecodesign requirements for energy-related products (2009/125/EC). Specific Implementing Measures are aimed at improving environmental performance of specific products or across multiple product types. ASUS provides product information on the CSR website. The further information could be found at <https://csr.asus.com/english/article.aspx?id=1555>.

低功率電波輻射性電機管理辦法

第十二條：經型式認證合格之低功率射頻電機，非經許可，公司、商號或使用者均不得擅自變更頻率、加大功率或變更原設計之特性及功能。

第十四條：低功率射頻電機之使用不得影響飛航安全及干擾合法通信；經發現有干擾現象時，應立即停用，並改善至無干擾時方得繼續使用。

Taiwan NCC Warning Statement

Article 12: Without permission, any company, firm or user shall not alter the frequency, increase the power, or change the characteristic and functions of the original design of the certified lower power frequency electric machinery.

Article 14: The application of lower power frequency electric machineries shall not affect the navigation safety nor interfere alegal communication, if an interference is found, the service will be suspended until improvement is made and theinterference no longer exists.

甲類警語

警告使用者：此為甲類資訊技術設備，於居住環境中使用時，可能會造成射頻擾動，在此種情況下，使用者會被要求採取某些適當的對策。

Taiwan BSMI Class A Notice

This product is Class A. In a domestic environment, this product may cause radio interference. You may be required to take adequate measures.

「產品之限用物質含有情況」之相關資訊，請參考下表：
Taiwan Declaration of Restricted Substances Marking

| 單元 (Unit) | 限用物質及其化學符號 (Restricted substances and its chemical symbols) | | | | | |
|--|--|----------------------|---------------------|--|--|---|
| | 鉛 Lead (Pb) | 汞 Mercury (Hg) | 鎘 Cadium (Cd) | 六價鉻 Hexavalent chromium (Cr ⁶⁺) | 多溴聯苯 Polybrominated biphenyls (PBB) | 多溴二苯醚 Polybrominated diphenyls ethers (PBDE) |
| 印刷電路板 及電子組件 PCB | — | ○ | ○ | ○ | ○ | ○ |
| 外殼 Chassis | — | ○ | ○ | ○ | ○ | ○ |
| 硬碟 Disk drive | — | ○ | ○ | ○ | ○ | ○ |
| 散熱設備 Thermal solutions | — | ○ | ○ | ○ | ○ | ○ |
| 其他及其 配件 (線材等) Accessories (e.g., cables) | — | ○ | ○ | ○ | ○ | ○ |

備考 1. “○” 係指該項限用物質之百分比含量未超出百分比含量基準值。

備考 2. “—” 係指該項限用物質為排除項目。

Note 1 “○” indicates that the percentage content of the restricted substance does not exceed the percentage of reference value of presence.

Note 2 The “—” indicates that the restricted substance corresponds to the exemption.

ENERGY STAR® Qualified Product

ENERGY STAR® is a joint program of the U.S. Environmental Protection Agency and the U.S. Department of Energy helping us all save money and protect the environment through energy efficient products and practices.



All ASUS products with the ENERGY STAR® logo comply with the ENERGY STAR® standard, and the power management feature is enabled by default. The monitor is automatically set to sleep after 10 minutes of user inactivity; the computer is automatically set to sleep after 30 minutes of user inactivity. To wake your computer, click the mouse, press any key on the keyboard, or press the power button.

Please visit <http://www.energystar.gov/powermanagement> for detail information on power management and its benefits to the environment. In addition, please visit <http://www.energystar.gov> for detail information on the ENERGY STAR® joint program.

NOTE: ENERGY STAR® is NOT supported on FreeDOS and Linux-based operating systems.

UK: The Radio Equipment Regulations 2017 (S.I. 2017/1206)

Simplified UKCA Declaration of Conformity

ASUSTek Computer Inc. hereby declares that this device is in compliance with the essential requirements and other relevant provisions of The Radio Equipment Regulations 2017 (S.I. 2017/1206). Full text of UKCA declaration of conformity is available at <https://www.asus.com/support/>.

The WiFi operating in the band 5150-5350MHz shall be restricted to indoor use for country listed below:

UK

UKCA RF Output table (The Radio Equipment Regulations 2017)

AZWAVE (Model: QCA6174A-5)

| Function | Frequency | Maximum Output Power (EIRP) |
|-----------|-----------------|-----------------------------|
| WiFi | 2412 - 2472 MHz | 18 dBm |
| | 5150 - 5350 MHz | 22 dBm |
| | 5470 - 5725 MHz | 20 dBm |
| Bluetooth | 2402 - 2480 MHz | 8 dBm |

UKCA RF Output table (The Radio Equipment Regulations 2017)

QUECTEL (Model: EC25-G)

| Radio Type | Description | Frequency | Maximum Output Power (EIRP) |
|------------|-------------|-----------------|-----------------------------|
| WCDMA | 900 | 880 - 915 MHz | 35.0 dBm |
| | 1800 | 1710 - 1785 MHz | 32.0 dBm |
| | Band 1 | 1920 - 1980 MHz | 25.0 dBm |
| | Band 5 | 824 - 849 MHz | 25.0 dBm |
| | Band 8 | 880 - 915 MHz | 25.0 dBm |
| LTE | B1 | 1920 - 1980 MHz | 25.0 dBm |
| | B3 | 1710 - 1785 MHz | 25.0 dBm |
| | B5 | 824 - 849 MHz | 25.0 dBm |
| | B7 | 2500 - 2570 MHz | 25.0 dBm |
| | B8 | 880 - 915 MHz | 25.0 dBm |
| | B20 | 832 - 862 MHz | 25.0 dBm |
| | B28 | 703 - 748 MHz | 25.0 dBm |
| | B38 | 2570 - 2620 MHz | 25.0 dBm |
| | B40 | 2300 - 2400 MHz | 25.0 dBm |

EU: Radio Equipment Directive (Directive 2014/53/EU)

Simplified EU Declaration of Conformity

ASUSTek Computer Inc. hereby declares that this device is in compliance with the essential requirements and other relevant provisions of Directive 2014/53/EU. Full text of EU declaration of conformity is available at <https://www.asus.com/support/>
The WiFi operating in the band 5150-5350MHz shall be restricted to indoor use for countries listed in the table below:

Déclaration simplifiée de conformité de l'UE

ASUSTek Computer Inc. déclare par la présente que cet appareil est conforme aux critères essentiels et autres clauses pertinentes de la directive 2014/53/EU. La déclaration de conformité de l'UE peut être téléchargée à partir du site internet suivant :
<https://www.asus.com/support/>

Dans la plage de fréquence 5150-5350 MHz, le Wi-Fi est restreint à une utilisation en intérieur dans les pays listés dans le tableau ci-dessous:

Vereinfachte EU-Konformitätserklärung

ASUSTek COMPUTER INC erklärt hiermit, dass dieses Gerät mit den grundlegenden Anforderungen und anderen relevanten Bestimmungen der Richtlinie 2014/53/EU übereinstimmt. Der gesamte Text der EU-Konformitätserklärung ist verfügbar unter:
<https://www.asus.com/support/>

Der WLAN-Betrieb im Band von 5150-5350 MHz ist für die in der unteren Tabelle aufgeführten Länder auf den Innenbereich beschränkt:

Dichiarazione di conformità UE semplificata

ASUSTek Computer Inc. con la presente dichiara che questo dispositivo è conforme ai requisiti essenziali e alle altre disposizioni pertinenti con la direttiva 2014/53/EU. Il testo completo della dichiarazione di conformità UE è disponibile all'indirizzo:
<https://www.asus.com/support/>

L'utilizzo della rete Wi-Fi con frequenza compresa nell'intervallo 5150-5350MHz deve essere limitato all'interno degli edifici per i paesi presenti nella seguente tabella:

Упрощенное заявление о соответствии европейской директиве

ASUSTek Computer Inc. заявляет, что устройство соответствует основным требованиям и другим соответствующим условиям директивы 2014/53/EU. Полный текст декларации соответствия ЕС доступен на <https://www.asus.com/support/>

Работа WiFi в диапазоне частот 5150-5350 должна быть ограничена использованием в помещениях для стран, перечисленных в таблице ниже:

إعلان التوافق المبسط الصادر عن الاتحاد الأوروبي

تقر شركة ASUSTek Computer أن هذا الجهاز يتوافق مع المتطلبات الأساسية والأحكام الأخرى ذات الصلة الخاصة بتوجيه 2014/53/EU. يتوفر النص الكامل لإعلان التوافق الصادر عن الاتحاد الأوروبي على:

<https://www.asus.com/support/>

يجب حصر استخدام WiFi العاملة بـ 5150-5350 ميجا هرتز على الاستخدام المنزلي للبلدان المدرجة بالجدول.

Опростена декларация за съответствие на ЕС

С настоящото ASUSTek Computer Inc. декларира, че това устройство е в съответствие със съществените изисквания и другите приложими постановления на свързаната Директива 2014/53/ЕС. Пълният текст на ЕС декларация за съвместимост е достъпен на адрес <https://www.asus.com/support/>

WiFi, работеща в диапазон 5150-5350MHz, трябва да се ограничи до употреба на закрито за страните, посочени в таблицата по-долу:

Declaração de Conformidade UE Simplificada

ASUSTek Computer Inc. declara que este dispositivo está em conformidade com os requisitos essenciais e outras disposições relevantes relacionadas às diretivas 2014/53/UE. O texto completo da declaração de conformidade CE está disponível em <https://www.asus.com/support/>

O WiFi operando na banda 5150-5350MHz deve ser restrito para uso interno para os países listados na tabela abaixo:

Pojednostavljena EU Izjava o sukladnosti

ASUSTek Computer Inc. ovim izjavljuje da je ovaj uređaj sukladan s bitnim zahtjevima i ostalim odgovarajućim odredbama direktive 2014/53/EU. Cijeli tekst EU izjave o sukladnosti dostupan je na <https://www.asus.com/support/>

WiFi koji radi na opsegu frekvencija 5150-5350 MHz bit će ograničen na upotrebu u zatvorenom prostoru u zemljama na donjem popisu:

Zjednodušené prohlášení o shodě EU

Společnost ASUSTek Computer Inc. tímto prohlašuje, že toto zařízení splňuje základní požadavky a další příslušná ustanovení směrnice 2014/53/EU. Plně znění prohlášení o shodě EU je k dispozici na adrese <https://www.asus.com/support/>
V zemích uvedených v tabulce je provoz sítě Wi-Fi ve frekvenčním rozsahu 5 150 - 5 350 MHz povolen pouze ve vnitřních prostorech:

Forenklet EU-overensstemmelseserklæring

ASUSTEK Computer Inc. erklærer hermed at denne enhed er i overensstemmelse med hovedkravene og øvrige relevante bestemmelser i direktivet 2014/53/EU. Hele EU-overensstemmelseserklæringen kan findes på <https://www.asus.com/support/>
Wi-Fi, der bruger 5150-5350 MHz skal begrænses til indendørs brug i lande, der er anført i tabellen:

Vereenvoudigd EU-conformiteitsverklaring

ASUSTEK Computer Inc. verklaart hierbij dat dit apparaat voldoet aan de essentiële vereisten en andere relevante bepalingen van Richtlijn 2014/53/EU. De volledige tekst van de EU-conformiteitsverklaring is beschikbaar op <https://www.asus.com/support/>
De WiFi op 5150-5350MHz zal beperkt zijn tot binnengebruik voor in de tabel vermelde landen:

Lihtsustatud EÜ vastavusdeklaratsioon

Käesolevaga kinnitab ASUSTEK Computer Inc, et seade vastab direktiivi 2014/53/EÜ olulistele nõuetele ja teistele asjakohastele sätetele. EL vastavusdeklaratsiooni täistekst on saadaval veebisaidil <https://www.asus.com/support/>
Sagedusvahemikus 5150-5350 MHz töötava WiFi kasutamine on järgmistes riikides lubatud ainult siseruumides:

Eurooppa - EY:n vaatimustenmukaisuusvakuutus

ASUSTEK Computer Inc. ilmoittaa täten, että tämä laite on direktiivin 2014/53/EU olennaisten vaatimusten ja muiden asiaankuuluvien lisäysten mukainen. Koko EY:n vaatimustenmukaisuusvakuutuksen teksti on luettavissa osoitteessa <https://www.asus.com/support/>

5 150 - 5 350 MHz:n taajuudella toimiva WiFi on rajoitettu sisäkäyttöön taulukossa luetelluissa maissa:

تبیت از نسخه ساده شده بیانه اتحادیه اروپا

ASUSTEK Computer Inc در اینجا اعلام می کند که این دستگاه با نیازهای اساسی و سایر مقررات مربوط به بیانه 2014/53/EU مطابقت دارد. متن کامل پیروی از این بیانه اتحادیه اروپا در این آدرس موجود است:

<https://www.asus.com/support/>

عملکرد 5150-5350 مگاهرتز برای WiFi باید برای استفاده در فضای داخل ساختمان برای کشورهای فهرست شده در جدول، محدود شود.

Απλοποιημένη Δήλωση Συμμόρφωσης ΕΕ

Διά του παρόντος η ASUSTEK Computer Inc. δηλώνει ότι αυτή η συσκευή είναι συμμόρφη με τις βασικές προϋποθέσεις και άλλες σχετικές διατάξεις της Οδηγίας 2014/53/ΕΕ. Το πλήρες κείμενο της δήλωσης συμμόρφωσης της ΕΕ είναι διαθέσιμο στη διεύθυνση <https://www.asus.com/support/>

To WiFi που λειτουργεί στη ζώνη 5150-5350MHz περιορίζεται για χρήση σε εσωτερικού χώρου για τις χώρες που αναφέρονται στον παρακάτω πίνακα:

הצהרת תאימות רגולטורית מקוצרת עבור האיחוד אירופי

ASUSTEK Computer Inc. מצהירה בזאת כי מכשיר זה תואם לדרישות החיוביות ולשאר הסעיפים הרלוונטיים של תקנה 2014/53/ΕΕ. ניתן לקרוא את הנוסח המלא של הצהרת התאימות הרגולטורית עבור האיחוד האירופי בתוכנית:

<https://www.asus.com/support/>

יש להגביל רשתות Wi-Fi הפועלות ברצועת התדרים 5150-5350MHz לשימוש בתוך מבנים סגורים בארצות המפורסות ברשימה הבאה:

EGYSZERŰSÍTETT EU MEGFELELŐSÉGI NYILATKOZAT

Az ASUSTEK Computer Inc. ezennel kijelenti, hogy ez az eszköz megfelel az 2014/53/EU sz. irányelv alapvető követelményeinek és egyéb vonatkozó rendelkezéseinek. Az EU megfelelési nyilatkozat teljes szövegét a következő weboldalon tekintheti meg: <https://www.asus.com/support/>

Az 5150-5350 MHz-es sávban működő Wi-Fi-t beltéri használatra kell korlátozni az alábbi táblázatban felsorolt országokban:

Pernyataan Kesesuaian UE yang Disederhanakan

ASUSTEK Computer Inc. dengan ini menyatakan bahwa perangkat ini memenuhi persyaratan utama dan ketentuan relevan lainnya yang terdapat pada Petunjuk 2014/53/EU. Teks lengkap pernyataan kesesuaian EU tersedia di: <https://www.asus.com/support/>

WiFi yang Beroperasi pada 5150-5350 MHz akan terbatas untuk penggunaan dalam ruangan di negara yang tercantum dalam tabel

Vienkāršota ES atbilstības paziņojums

ASUSTek Computer Inc. ar šo paziņo, ka šī ierīce atbilst Direktīvas 2014/53/ES būtiskajām prasībām un citiem citiem saistošajiem nosacījumiem. Pilns ES atbilstības paziņojuma teksts pieejams šeit: <https://www.asus.com/support/>

Wi-Fi darbība 5150–5350 MHz ir jāierobežo lietošanai telpās valstīs, kuras norādītas tālāk.

Supaprastinta ES atitiktības deklarācija

Šīame dokumente bendrovē, ASUSTek Computer Inc." pareiškia, kad šis prietaiss atitinka pagrindinius reikalavimus ir kitas susijusias Direktīvyvos 2014/53/ES nuostatas. Visas ES atitiktības deklarācijas tekstas pateikiamas čia: <https://www.asus.com/support/>

Toliau nurodytose šalyse, "WiFi" ryšiu, veikiančiu 5 150–5 350 MHz dažnio juostoje, galima naudotis tik patalpose:

Forenklet EU-samsvarserklæring

ASUSTek Computer Inc. erklærer herved at denne enheten er i samsvar med hovedsaklige krav og andre relevante forskrifter i direktivet 2014/53/EU. Fullstendig tekst for EU-samsvarserklæringen finnes på: <https://www.asus.com/support/>

Wi-Fi-området 5150–5350 MHz skal begrenses til innendørs bruk for landene som er oppført i tabellen:

Uproszczona deklaracja zgodności UE

Firma ASUSTek Computer Inc. niniejszym oświadcza, że urządzenie to jest zgodne z zasadniczymi wymogami i innymi właściwymi postanowieniami dyrektywy 2014/53/EU. Pełny tekst deklaracji zgodności UE jest dostępny pod adresem <https://www.asus.com/support/>

W krajach wymienionych w tabeli działanie sieci Wi-Fi w paśmie 5150–5350 MHz powinno być ograniczone wyłącznie do pomieszczeń:

Declaração de Conformidade Simplificada da UE

A ASUSTek Computer Inc. declara que este dispositivo está em conformidade com os requisitos essenciais e outras disposições relevantes da Diretiva 2014/53/UE. O texto integral da declaração de conformidade da UE está disponível em <https://www.asus.com/support/>

A utilização das frequências WiFi de 5150 a 5350MHz está restrita a ambientes interiores nos países apresentados na tabela:

Declarație de conformitate UE, versiune simplificată

Prin prezenta, ASUSTek Computer Inc. declară că acest dispozitiv este în conformitate cu reglementările esențiale și cu celelalte prevederi relevante ale Directivei 2014/53/UE. Textul complet al declarației de conformitate UE este disponibil la adresa <https://www.asus.com/support/>

Pentru țările listate în tabelul de mai jos, rețelele WiFi care funcționează în banda de frecvență de 5.150-5.350 MHz trebuie utilizate doar în interior:

Pojednostavljena Deklaracija o usaglašenosti EU

ASUSTek Computer Inc. ovim izjavljuje da je ovaj uređaj usaglašen sa osnovnim zahtevima i drugim relevantnim odredbama Direktive 2014/53/EU. Ceo tekst Deklaracije o usaglašenosti EU dostupan je na lokaciji <https://www.asus.com/support/>

WiFi koji radi u frekventnom opsegu od 5150 MHz do 5350 MHz ograničen je isključivo na upotrebu u zatvorenom prostoru za zemlje navedene u tabeli ispod:

Zjednodušené vyhlásenie o zhode platné pre EU

Spoločnosť ASUSTek Computer Inc. týmto vyhlasuje, že toto zariadenie je v súlade so základnými požiadavkami a ďalšími príslušnými ustanoveniami smernice č. 2014/53/EU. Plné znenie vyhlásenia o zhode pre EU je k dispozícii na lokalite <https://www.asus.com/support/>

Činnosť WiFi v pásme 5150 - 5350 MHz bude obmedzená na použitie vo vnútornom prostredí pre krajiny uvedené v tabuľke nižšie:

Poenostavljena izjava EU o skladnosti

ASUSTek Computer Inc. tukaj izjavlja, da je ta naprava skladna s temeljnimi zahtevami in drugimi relevantnimi določili Direktive 2014/53/EU. Polno besedilo izjave EU o skladnosti je na voljo na <https://www.asus.com/support/>

WiFi, ki deluje v pasovnem območju 5150–5350 MHz, mora biti v državah, navedenih v spodnjem seznamu, omejen na notranjo uporabo:

Declaración de conformidad simplificada para la UE

Por la presente, ASUSTek Computer Inc. declara que este dispositivo cumple los requisitos básicos y otras disposiciones pertinentes de la directiva 2014/53/UE. En <https://www.asus.com/support/> está disponible el texto completo de la declaración de conformidad para la UE.

La conexión WiFi con una frecuencia de funcionamiento de 5150-5350 MHz se restringirá al uso en interiores para los países enumerados en la tabla:

Förenklad EU-försäkran om överensstämmelse

ASUSTek Computer Inc. deklarerar härmed att denna enhet överensstämmer med de grundläggande kraven och andra relevanta bestämmelser i direktiv 2014/53/EU. Fullständig text av EU-försäkran om överensstämmelse finns på <https://www.asus.com/support/>

WiFi som använder 5150-5350 MHz kommer att begränsas för användning inomhus i de länder som anges i tabellen:

ประกาศเกี่ยวกับความสอดคล้องของสหภาพยุโรปแบบย่อ

ASUSTek Computer Inc. ขอประกาศในที่นี้ว่าอุปกรณ์นี้มีความสอดคล้องกับความต้องการที่จำเป็นและเงื่อนไขที่เกี่ยวข้องอื่น ๆ ของบทบัญญัติข้อกำหนด 2014/53/EU เนื้อหาที่สมบูรณ์ของประกาศความสอดคล้องกับ EU มีอยู่ที่ <https://www.asus.com/support/> การทำงานของ WiFi ที่ 5150-5350MHz ถูกจำกัดให้ใช้ในอาคารสำหรับประเทศที่แสดงในตาราง

Basitleştirilmiş AB Uyumluluk Bildirimi

ASUSTek Computer Inc., bu aygıtın 2014/53/EU Yönergesinin temel gereksinimlerine ve diğer ilgili hükümlerine uygun olduğunu bildirir. AB uyumluluk bildiriminin tam metni şu adreste bulunabilir: <https://www.asus.com/support/> 5150-5350 MHz arasındaki WiFi çalışması, tabloda listelenen ülkeler için iç mekân kullanımıyla kısıtlanacaktır.

Спрощена декларація про відповідність нормам ЄС

ASUSTek Computer Inc. заявляє, що цей пристрій відповідає основним вимогам та іншим відповідним вимогам Директиви 2014 / 53 / EU. Повний текст декларації відповідності нормам ЄС доступний на <https://www.asus.com/support/>

Робота Wi-Fi на частоті 5150-5350 МГц обмежується використанням у приміщенні для країн, поданих у таблиці нижче:

| | | | | | | |
|----|----|----|----|---------|----|----|
| AT | BE | BG | CZ | DK | EE | FR |
| DE | IS | IE | IT | EL | ES | CY |
| LV | LI | LT | LU | HU | MT | NL |
| NO | PL | PT | RO | SI | SK | TR |
| FI | SE | CH | HR | UK (NI) | | |

CE RED RF Output table (Directive 2014/53/EU)

AZWAVE (Model: QCA6174A-5)

| Function | Frequency | Maximum Output Power (EIRP) |
|-----------|-----------------|-----------------------------|
| WiFi | 2412 - 2472 MHz | 18 dBm |
| | 5150 - 5350 MHz | 22 dBm |
| | 5470 - 5725 MHz | 20 dBm |
| Bluetooth | 2402 - 2480 MHz | 8 dBm |

For the standard EN 300 440, if this device operates in 5725-5875 MHz, it will be considered as a receiver category 2.

CE RED RF Output table (Directive 2014/53/EU)
QUECTEL (Model: EC25-G)

| Radio Type | Description | Frequency | Maximum Output Power (EIRP) |
|------------|-------------|-----------------|-----------------------------|
| WCDMA | 900 | 880 - 915 MHz | 35.0 dBm |
| | 1800 | 1710 - 1785 MHz | 32.0 dBm |
| | Band 1 | 1920 - 1980 MHz | 25.0 dBm |
| | Band 5 | 824 - 849 MHz | 25.0 dBm |
| | Band 8 | 880 - 915 MHz | 25.0 dBm |
| LTE | B1 | 1920 - 1980 MHz | 25.0 dBm |
| | B3 | 1710 - 1785 MHz | 25.0 dBm |
| | B5 | 824 - 849 MHz | 25.0 dBm |
| | B7 | 2500 - 2570 MHz | 25.0 dBm |
| | B8 | 880 - 915 MHz | 25.0 dBm |
| | B20 | 832 - 862 MHz | 25.0 dBm |
| | B28 | 703 - 748 MHz | 25.0 dBm |
| | B38 | 2570 - 2620 MHz | 25.0 dBm |
| | B40 | 2300 - 2400 MHz | 25.0 dBm |

Service and Support

Visit our multi-language website at <https://www.asus.com/support/>.

