



ASUS NUC 13 Rugged Board / Kit

Technical Product Specification

Regulatory Models: NUC13BRK (Slim Kit)
NUC13BRF (Tall Kit)
NUC13BRB (Board)

June 2024
Revision 1.3

ASUS NUC Boards NUC13BR may contain design defects or errors known as errata that may cause the product to deviate from published specifications. Current characterized errata, if any, are documented in ASUS NUC Board NUC13BR Specification Update.

Revision History

Table 1. Revision History

| Revision | Revision History | Date |
|-----------------|---|-------------|
| 1.0 | Release of the ASUS NUC 13 Rugged Board/Kit Technical Product Specification | April 2024 |
| 1.1 | Updated HDMI Trademark Logo/Disclaimer Requirement | June 2024 |
| | | |
| | | |

Disclaimer

COPYRIGHT INFORMATION

No part of this manual, including the products and software described in it, may be reproduced, transmitted, transcribed, stored in a retrieval system, or translated into any language in any form or by any means, except documentation kept by the purchaser for backup purposes, without the express written permission of ASUSTeK COMPUTER INC. ("ASUS").

ASUS PROVIDES THIS MANUAL "AS IS" WITHOUT WARRANTY OF ANY KIND, EITHER EXPRESS OR IMPLIED, INCLUDING BUT NOT LIMITED TO THE IMPLIED WARRANTIES OR CONDITIONS OF MERCHANTABILITY OR FITNESS FOR A PARTICULAR PURPOSE. IN NO EVENT SHALL ASUS, ITS DIRECTORS, OFFICERS, EMPLOYEES OR AGENTS BE LIABLE FOR ANY INDIRECT, SPECIAL, INCIDENTAL, OR CONSEQUENTIAL DAMAGES (INCLUDING DAMAGES FOR LOSS OF PROFITS, LOSS OF BUSINESS, LOSS OF USE OR DATA, INTERRUPTION OF BUSINESS AND THE LIKE), EVEN IF ASUS HAS BEEN ADVISED OF THE POSSIBILITY OF SUCH DAMAGES ARISING FROM ANY DEFECT OR ERROR IN THIS MANUAL OR PRODUCT.

Products and corporate names appearing in this manual may or may not be registered trademarks or copyrights of their respective companies and are used only for identification or explanation and to the owners' benefit, without intent to infringe.

SPECIFICATIONS AND INFORMATION CONTAINED IN THIS MANUAL ARE FURNISHED FOR INFORMATIONAL USE ONLY AND ARE SUBJECT TO CHANGE AT ANY TIME WITHOUT NOTICE AND SHOULD NOT BE CONSTRUED AS A COMMITMENT BY ASUS. ASUS ASSUMES NO RESPONSIBILITY OR LIABILITY FOR ANY ERRORS OR INACCURACIES THAT MAY APPEAR IN THIS MANUAL, INCLUDING THE PRODUCTS AND SOFTWARE DESCRIBED IN IT.

Copyright © 2023 ASUSTeK COMPUTER INC. All Rights Reserved.

LIMITATION OF LIABILITY

Circumstances may arise where because of a default on ASUS' part or other liability, you are entitled to recover damages from ASUS. In each such instance, regardless of the basis on which you are entitled to claim damages from ASUS, ASUS is liable for no more than damages for bodily injury (including death) and damage to real property and tangible personal property; or any other actual and direct damages resulted from omission or failure of performing legal duties under this Warranty Statement, up to the listed contract price of each product.

ASUS is only responsible for or indemnifying you for loss, damages or claims based on contract, tort, or infringement under this Warranty Statement.

This limit also applies to ASUS' suppliers and its resellers. It is the maximum for which ASUS, its suppliers, and your reseller are collectively responsible.

UNDER NO CIRCUMSTANCES IS ASUS LIABLE FOR ANY OF THE FOLLOWING: (1) THIRD-PARTY CLAIMS AGAINST YOU FOR DAMAGES; (2) LOSS OF, OR DAMAGE TO, YOUR RECORDS OR DATA; OR

(3) SPECIAL, INCIDENTAL, OR INDIRECT DAMAGES OR FOR ANY ECONOMIC CONSEQUENTIAL DAMAGES (INCLUDING LOST PROFITS OR SAVINGS), EVEN IF ASUS, ITS SUPPLIERS OR YOUR RESELLER IS INFORMED OF THEIR POSSIBILITY.

SERVICE AND SUPPORT

Visit our multi-language website at <https://www.asus.com/support/>.

Preface

This Technical Product Specification (TPS) specifies the board layout, components, connectors, power and environmental requirements, and the BIOS for ASUS NUC Rugged NUC13BR Board/Kits. Some features are only available on certain SKUs.



NOTE

In this document, the use of “ASUS NUC 13 Rugged Kit” will refer to the NUC13BRK (Slim Kit) NUC13BRF (Tall Kit). The usage of “NUC 13 Rugged Kit” refers to the ASUS NUC 13 Rugged product contained inside the NUC 13 Rugged Kit.

Intended Audience

The TPS is intended to provide detailed, technical information about ASUS NUC Rugged NUC13BR Board and Kit, and its components to the vendors, system integrators, and other engineers and technicians who need this level of information. It is specifically *not* intended for general audiences.

What This Document Contains

Table 2. Document Contents Description

| Chapter | Description |
|---------|--|
| 1 | An overview of the features and specifications of the ASUS NUC 13 Rugged NUC13BR |
| 2 | The figures, layouts, and physical description of the ASUS NUC 13 Rugged NUC13BR Board |
| 3 | Detailed descriptions of the features and specifications |
| 4 | Technical references and considerations |
| 5 | An overview of BIOS features and specifications |

Typographical Conventions

This section contains information about the conventions used in this specification. Not all of these symbols and abbreviations appear in all specifications of this type.

Notes, Cautions, and Warnings



NOTE

Notes call attention to important information.



CAUTION

Cautions are included to help you avoid damaging hardware or losing data

Other Common Notation

| | |
|-------|--|
| # | Used after a signal name to identify an active-low signal (such as USBP0#) |
| GB | Gigabyte (1,073,741,824 bytes) |
| GB/s | Gigabytes per second |
| Gb/s | Gigabits per second |
| KB | Kilobyte (1024 bytes) |
| Kb | Kilobit (1024 bits) |
| kb/s | 1000 bits per second |
| MB | Megabyte (1,048,576 bytes) |
| MB/s | Megabytes per second |
| Mb | Megabit (1,048,576 bits) |
| Mb/s | Megabits per second |
| TDP | Thermal Design Power |
| Xxh | An address or data value ending with a lowercase h indicates a hexadecimal value. |
| x.x V | Volts. Voltages are DC unless otherwise specified. |
| * | This symbol is used to indicate third-party brands and names that are the property of their respective owners. |

Board Identification Information

Basic ASUS NUC Board NUC13BRK Identification Information

Table 3. Board/BIOS Identification

| AA Revision | BIOS Revision | Notes |
|-------------|---------------|-------|
| | BRADLCPX.0038 | 1 |
| | BRADLCPX.0039 | 1 |

Notes:

1. The AA number is found on a small label on the component side of the board.

Production Identification Information

Table 4. ASUS NUC Products NUC13BR Identification Information

| Product Name | ASUS NUC Board | Processor |
|---------------------|-----------------------|----------------------|
| NUC13BRK | NUC13BRKP2 | Intel® Processor N50 |
| NUC13BRF | NUC13BRFA2 | Intel® Atom® x7211E |
| | NUC13BRBA2 | |
| NUC13BRB | NUC13BRBA4 | Intel® Atom® x7425E |
| | NUC13BRFA4 | |

Notes:

Specification Changes or Clarifications

The table below indicates the Specification Changes or Specification Clarifications that apply to the ASUS NUC Rugged NUC13BR Board and Kit.

Specification Changes or Clarifications

| Date | Type of Change | Description of Changes or Clarifications |
|-----------|----------------|--|
| June 2024 | Trademark Logo | Updated new HDMI Trademark Logo/Disclaimer Requirement |
| | | |

Errata

Current characterized errata, if any, will be documented in Section 3 of this Technical Product Specification.

Online Support

To Find Information About...

ASUS NUC Board/Kit/Rugged PC
NUC13BR
ASUS NUC Board/Kit/Rugged PC Support
High level details for ASUS NUC
Board/Kit/Rugged PC NUC13BR
BIOS and driver updates
Tested memory
Integration information
Processor datasheet
Regulatory documentation

Visit this World Wide Web site:

<https://www.asus.com/support/>
<https://www.asus.com/support/>
<https://www.asus.com/support/>
<https://www.asus.com/support/Download-Center/>
<https://www.asus.com/support/>
<https://www.asus.com/support/>
<https://www.asus.com/support/>
<https://www.asus.com/support/>

Contents

| | |
|---|-----------|
| Revision History | ii |
| Disclaimer | ii |
| Preface..... | iv |
| Intended Audience | iv |
| What This Document Contains | iv |
| Typographical Conventions..... | iv |
| Board Identification Information..... | v |
| Production Identification Information | vi |
| Specification Changes or Clarifications | vii |
| Errata..... | vii |
| Online Support..... | vii |
| Contents..... | i |
| 1 Product Description..... | 1 |
| 1.1 Overview | 1 |
| 1.2 Summary of Standard Kit and Board SKUs | 1 |
| 1.3 Product Feature Summary Tables | 2 |
| 1.3.1 ASUS NUC 13 Rugged Kit Product Summary | 2 |
| 2 Technical Reference | 5 |
| 2.1 Block Diagrams..... | 5 |
| 2.1.1 Block Diagram - NUC 13 Rugged | 5 |
| 2.1.2 Board Layout (Top) | 6 |
| 2.1.3 Tall Chassis Layout (I/O Ports) | 7 |
| 2.1.4 Slim Chassis Layout (I/O Ports) | 8 |
| 2.1.5 Chassis Expandability Options | 9 |
| 2.2 Processor Support Features..... | 10 |
| 2.3 Processor Graphics Subsystem..... | 10 |
| 2.3.1 Display Emulation | 11 |
| 2.3.2 High-Definition Multimedia Interface* (HDMI*) | 11 |
| 2.3.3 NVMe/SATA Interfaces | 13 |
| 2.3.4 Real-Time Clock Subsystem..... | 13 |
| 2.4 LAN Subsystem..... | 14 |
| 2.4.1 RJ-45 LAN Connector with Integrated LEDs..... | 14 |
| 2.5 MIPI CSI Interfaces | 15 |
| 2.5.1 The pin out of the multiple MIPI headers | 15 |
| 2.5.2 Enable the MIPI CSI Interfaces in BIOS Menu..... | 16 |

| | | |
|----------|---|-----------|
| 2.6 | Hardware Management Subsystem..... | 17 |
| 2.6.1 | Fanless Thermal Solution..... | 17 |
| 2.6.2 | System States and Power States..... | 17 |
| 2.6.3 | Wake-up Devices and Events..... | 17 |
| 2.6.4 | Signal Tables for the Connectors and Headers..... | 18 |
| 2.6.5 | M.2 30x42 Pin-Out (Mechanical Key B) detail info..... | 22 |
| 2.6.6 | Back Panel Header (2.0 mm Pitch)..... | 23 |
| 2.7 | Mechanical Considerations..... | 28 |
| 2.7.1 | Chassis Images..... | 28 |
| 2.7.2 | Thermal Considerations..... | 29 |
| 2.7.3 | Reliability..... | 29 |
| 2.8 | Environmental..... | 30 |
| 2.9 | Overview of BIOS Features..... | 32 |
| 2.10 | Introduction..... | 32 |
| 2.11 | BIOS Updates..... | 32 |
| 2.12 | BIOS Recovery..... | 32 |
| 2.13 | Boot Options..... | 33 |
| 2.13.1 | Boot Device Selection During Post..... | 33 |
| 2.13.2 | Power Button Menu..... | 33 |
| 2.14 | Hard Disk Drive Password Security Feature..... | 34 |
| 2.15 | BIOS Security Features..... | 35 |
| 2.16 | BIOS Error Messages..... | 36 |
| 3 | Characterized Errata..... | 36 |

Figures

| | |
|--|----|
| Figure 1. Block Diagram – NUC 13 Rugged Kit | 5 |
| Figure 2. Major Board Components (Top)..... | 6 |
| Figure 3. Tall Chassis Layout – NUC 13 Rugged Kit | 7 |
| Figure 4. Slim Chassis Layout – NUC 13 Rugged Kit..... | 8 |
| Figure 5. Tall Chassis Side Panel Expansion Slot | 9 |
| Figure 6. LAN Connectors Location | 14 |
| Figure 7. PIN Out of MIPI Headers | 15 |
| Figure 8. USB Header PIN Layout..... | 18 |
| Figure 9. Connection Diagram for Front Panel Header (2.0 mm Pitch) | 23 |
| Figure 10. BIOS Security Jumper Header..... | 25 |
| Figure 11. Tall Chassis Image Front | 28 |
| Figure 12. Tall Chassis Image Back..... | 28 |
| Figure 13. Short Chassis Image Front..... | 28 |
| Figure 14. Short Chassis Image Back..... | 29 |

Tables

| | |
|--|----|
| Table 1. Revision History..... | ii |
| Table 2. Document Contents Description..... | iv |
| Table 3. Board/BIOS Identification | v |
| Table 4. ASUS NUC Products NUC13BR Identification Information | vi |
| Table 5. Summary of Standard Kits and Board SKUs..... | 1 |
| Table 6. Feature Summary..... | 2 |
| Table 7. Additional Feature Summary..... | 4 |
| Table 9. Shown in Figure 3 Tall Chassis I/O Ports Description | 7 |
| Table 10. Shown in Figure 4. Slim Chassis I/O Ports Description | 8 |
| Table 11. TCC/TSN Feature support per processor | 10 |
| Table 12. LAN Connector LED States..... | 14 |
| Table 13. LAN Wake Events..... | 17 |
| Table 14. Internal USB 2.0 Headers (1.25 mm pitch)..... | 18 |
| Table 15. M.2 2280 Module (Mechanical Key M) Connector..... | 19 |
| Table 16. M.2 2230 Module (Mechanical Key E) Connector..... | 20 |
| Table 17. M.2 30x42 Module (Mechanical Key B) Connector..... | 21 |
| Table 18. Back Panel Header (2.0 mm pitch) | 23 |
| Table 19. States for a One-Color Power LED | 24 |
| Table 20. States for a Dual-Color Power LED | 24 |
| Table 21. BIOS Security Jumper Settings..... | 25 |
| Table 22. Internal Power Supply Connector Pins | 26 |
| Table 23. BIOS Security Jumper Settings..... | 27 |
| Table 24. Environmental Specifications | 30 |
| Table 25. Acceptable Drives/Media Type for BIOS Recovery | 32 |
| Table 26. Power Button Menu Options..... | 34 |
| Table 27. Master Key and User Hard Disk Drive Password Functions | 34 |
| Table 28. Supervisor and User Password Functions..... | 36 |
| Table 29. BIOS Error Messages | 36 |

1 Product Description

1.1 Overview

The ASUS NUC 13 Rugged Kit is a small form factor PC barebones kits. The NUC 13 Rugged Kit consists of the processor, chipset, memory slots, wireless, Bluetooth*, M.2 storage slots, integrated heat sink and fan. See Table 5 for a summary of Standard Kits and Board SKUs.

For information on compatible devices for use with the ASUS NUC 13 Rugged Kit see <https://www.asus.com/support/>.

1.2 Summary of Standard Kit and Board SKUs

The different versions of the ASUS NUC 13 Rugged Kit SKUs and Board are summarized in Table 5Table 5. Product Codes and MM#s for the SKUs below can be found at <https://www.asus.com/support/>.

Table 5. Summary of Standard Kits and Board SKUs

| Processor | Chassis | AC Cord (C5) | |
|--|---------|--------------------------------|--|
| Intel® Processor N50 (Config A) Technology | Slim | US, EU, CN, TW, JP, or No Cord | |
| | Tall | US, EU, or No Cord | |
| Intel Atom® Processor X7211E (Config B) | Slim | US, EU, or No Cord | |
| | Tall | US, EU, CN, TW, JP, or No Cord | |
| | Board | N/A | |
| Intel Atom® Processor X7425E (Config C) | Slim | US, EU, or No Cord | |
| | Tall | US, EU, CN, TW, JP, or No Cord | |
| | Board | N/A | |

¹“TW” refers to Taiwan | ²“CN” refers to China | ³“JP” refers to Japan



NOTE

ASUS NUC 13 Extreme Kits listed in Table 5 have been certified for use as a component in Information Technology Equipment in certain countries. The system integrator is responsible for testing and acquiring any additional country-specific regulatory approvals, including all system-wide certifications.



NOTE

For information on the ASUS NUC 13 Rugged Kit is available at <https://www.asus.com/support/>.

1.3 Product Feature Summary Tables

The following section presents a summary of the features for the ASUS NUC 13 Rugged Kits.

1.3.1 ASUS NUC 13 Rugged Kit Product Summary

Table 6 summarizes the major features of the ASUS NUC 13 Rugged Kits.

Table 6. Feature Summary

| | |
|-------------------------------|---|
| Board Dimensions | 146mm x 101.7mm x17.39H mm |
| Max Chassis Dimensions | Slim chassis: 174mm x 108mm x 25.9mm (+3.4mm rubber feet) Tall chassis: 174mm x 108mm x 35.8mm (+3.4mm rubber feet) |
| Processor | ASUS NUC 13 Rugged Boards and Kits have a soldered-down Alder-Lake-N processor from the list below. <ul style="list-style-type: none"> • Intel® Processor N50 (Config A) • Intel Atom® Processor X7211E (Config B) • Intel Atom® Processor X7425E (Config C) More information about Intel® processors can be found at https://ark.intel.com |
| Memory | 1x Single Channel DDR5-4800 SODIMM up to 16GB capacity <ul style="list-style-type: none"> • Only model with x7211E and x7425E support In-band ECC capability. More information about tested memory can be found at https://www.asus.com/support/ |
| Graphics | Integrated graphics support for processors with Intel® UHD Graphics Technology: <ul style="list-style-type: none"> • Supports up to dual 4K@60Hz display or dual 1080@60Hz (2 x HDMI 2.1 TMDS) • HDR (High Dynamic Range) support • Dual display pipes – supporting blending, color adjustments, scaling, and dithering. • Support for HDCP 2.3 • Codecs supported are detailed on http://www.intel.com/graphics • Support Headless, 2nd Virtual Display and Persistent Display Mode Operation |
| Audio | The processor supports the following audio formats over HDMI*: HBR Dolby TrueHD and DTS-HD Master Audio More information about software and drivers can be found at https://www.asus.com/support/Download-Center/ |
| Storage | 64GB eMMC soldered-down 1x M.2 2280 PCIe x2 Gen4x4, supports 128GB~4TB NVMe SSD 1x M.2 3042 PCIe SATA SSD w/ 1 x USB3.2 Gen2 |

| | |
|-----------------------------------|---|
| Communication | <p>Intel® Wi-Fi 6E AX210 (Gig+), M.2 2230 add-in card via M.2 2230 (key type E) connector</p> <ul style="list-style-type: none"> • 802.11ax R2 2x2, both with 160Mhz channel support + Bluetooth v5.3 • Maximum transfer speed up to 2.4 Gbps • Supports PCIe and USB <p>More information about Intel® wireless products can be found at https://ark.intel.com To obtain drivers visit https://www.asus.com/support/Download-Center/.</p> <p>Dual 2.5 Gigabit (10/100/1000/2500 Mbps) Ethernet ports</p> <ul style="list-style-type: none"> • Intel® Ethernet Controller I226-V (SKU Dependent) • Intel® Ethernet Controller I226-LM (SKU Dependent) • Single-port integrated multi-gigabit (up to 2.5G) – standard IEEE 802.3 Ethernet interface for 2500BASE-T, 1000BASE-T, 100BASE-TX, 10BASE-TE connections (IEEE 802.3, 802.3u, 802.3bz, and 802.3ab) • Full wake up support (S4 WOL not supported) • Supports for packets up to 9.5 KB (Jumbo Frames) <p>More information about Intel® Ethernet controllers can be found at https://ark.intel.com</p> |
| USB Ports and Headers | <p>2 x USB 3.2 Gen2 port (rear panel) 2 x USB 2.0 port (rear panel) 2 x USB 2.0 Headers (internal)</p> <p>More information about the location/pinout of the USB ports and headers can be found in Section 3.6.3 later in this document.</p> |
| Power | <p>Power Adapter</p> <ul style="list-style-type: none"> • 65W adapter ADP 20V, 3.25A 3P DT VI • 90W adapter ADP 20V, 4.5A 3P DT VI <p>Internal Power Header</p> <ul style="list-style-type: none"> • 4-pos/dual row (2x2) right-angled header <p>Power Input</p> <ul style="list-style-type: none"> • 12V_{DC} to 20V_{DC}+/- 5% with DC voltage protection |
| Operating Temperatures | <ul style="list-style-type: none"> • Intel® Atom® x7211E 0 - 50 °C External Ambient Temp • Intel® Atom® x7425E 0 - 50 °C External Ambient Temp • Intel® Processor N50 0 - 40 °C External Ambient Temp |
| BIOS | <p>ASUS BIOS resident in the Serial Peripheral Interface (SPI) Flash device</p> <ul style="list-style-type: none"> • Support for Advanced Configuration and Power Interface (ACPI), Plug and Play |
| Supported Operating System | <ul style="list-style-type: none"> • Windows 10 IOT-Enterprise LTSC 64-bit • Ubuntu 22.04 LTS • RedHat Enterprise Linux 9 • Windows 11 Pro 64-bit |
| Hardware Monitor Subsystem | <p>Hardware monitoring subsystem including: Voltage sense to detect out of range power supply voltages. Thermal sense to detect out of range thermal values</p> |
| Design for Rugged | <ul style="list-style-type: none"> • Rated IP50 • Industrial Design • Fanless |

¹ May not be available in all countries.

Table 7. Additional Feature Summary

| | |
|---------------------------------|--|
| MIPI Camera | ASUS NUC 13 Rugged NUC13BR supports 2x MIPI CSI Camera headers, which supports Vision Components or Paper Image off-the-shelf camera. |
| HDMI CEC API | Built-in support for HDMI CEC is available on both HDMI ports, which may be enabled in the BIOS for display power control, as well as via an API supporting other HDMI CEC functions. More information about the HDMI CEC API specification is available on https://www.intel.com/content/www/us/en/support/articles/000056864/intel-nuc.html |
| Sustained Operation | Qualified for 24x7 sustained operation |
| Auto RTC Reset | A Real-Time Clock (RTC) reset is triggered after three consecutive unsuccessful boot attempts. |
| Delayed AC Start | Short delay after AC power is applied before unit is ready to power on to protect the system against voltage fluctuations in environments where multiple devices are being powered on simultaneously |
| Reflectivity | All surfaces meet 20GE (20 Gloss Level/Gloss Units) of shininess by measurement of Glanz |
| Kensington Security Slot | Available on the right side of the chassis when viewed from the front |
| Cable Locking Arm | ASUS NUC Rugged PCs and Kits NUC13BR ship with a cable locking arm on the back panel of the chassis. The cable locking arm reduces stress on the power adapter cable in certain positions and prevents unintended losses of power |
| LED Status Indicators | ASUS NUC 13 Rugged Kits feature three System Status LEDs to represent overall boot health (useful for headless deployments) as well as firmware/software robustness capabilities. There are three Network Status LEDs representing overall network connectivity. |



The terms HDMI, HDMI High-Definition Multimedia Interface, HDMI trade dress and the HDMI Logos are trademarks or registered trademarks of HDMI Licensing Administrator, Inc.

2 Technical Reference

2.1 Block Diagrams

2.1.1 Block Diagram – NUC 13 Rugged

Figure 1 shows a block diagram of the major functional areas of the ASUS NUC 13 Rugged Kit.

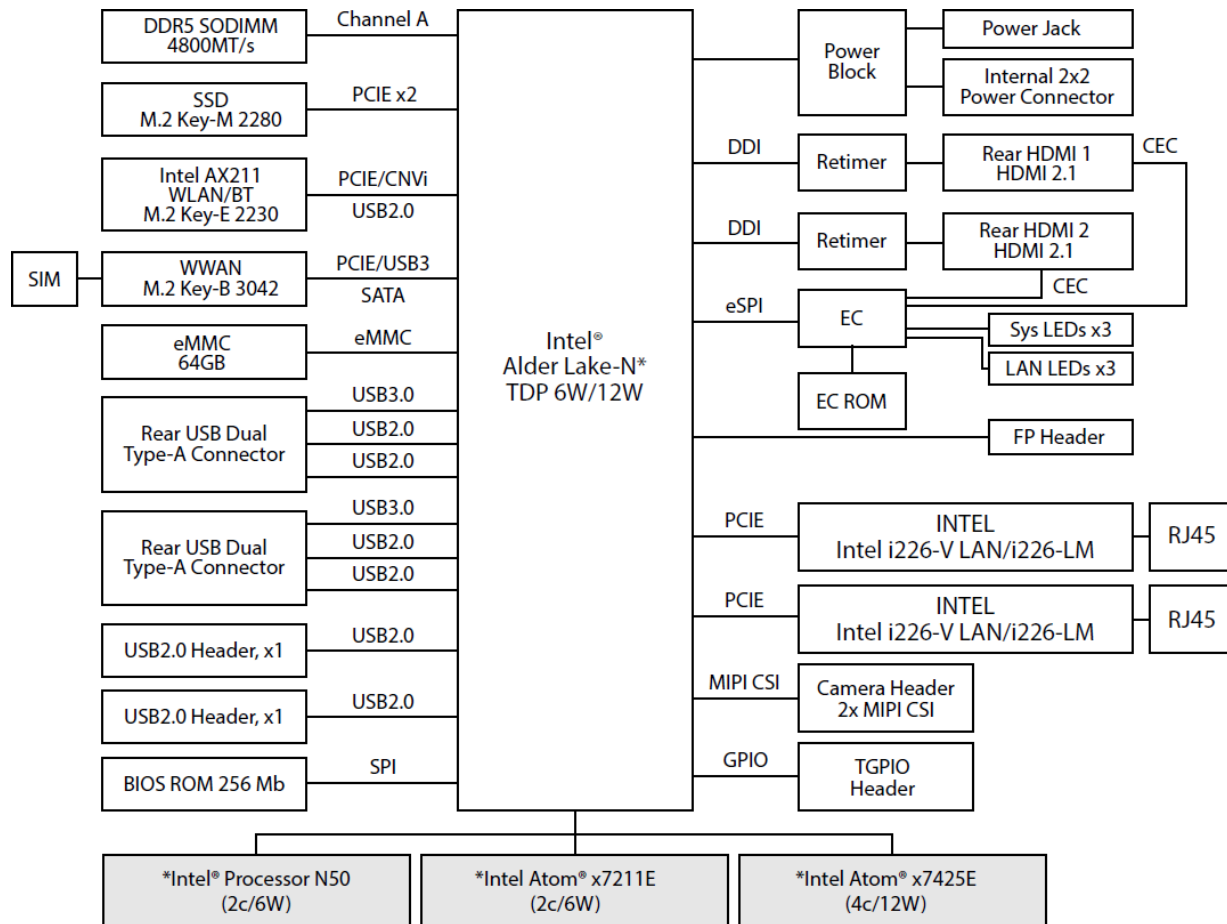

Figure 1. Block Diagram – NUC 13 Rugged Kit

2.1.2 Board Layout (Top)

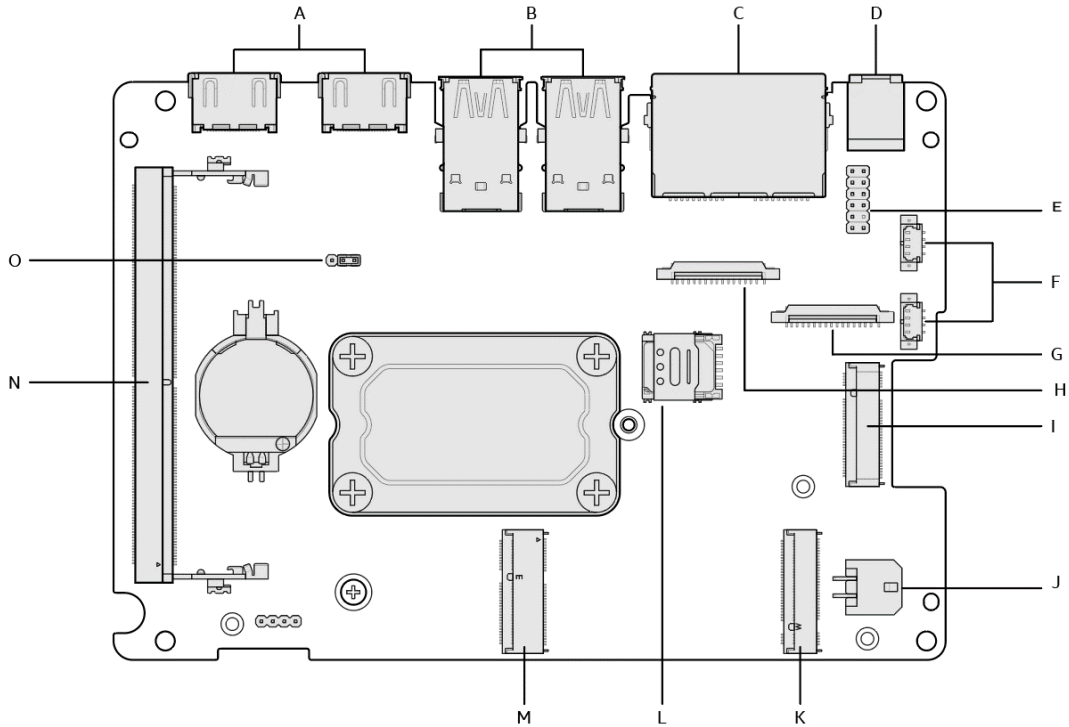

Figure 2. Major Board Components (Top)

Table 8 Showing Figure 2 Major Board Components

| Item from | Description |
|-----------|--|
| A | HDMI Connectors |
| B | USB Type-A Connectors |
| C | RJ-45 LAN Ports |
| D | Power Connector (12V _{DC} to 20V _{DC} +/- 5% with DC voltage protection) |
| E | Front Panel Header |
| F | USB Internal Header |
| G | MIPI CSI Header |
| H | MIPI CSI Header |
| I | M.2 Key B 3042 |
| J | Internal Power Header |
| K | M.2 Key-M 2280 |
| L | SIM Card Socket |
| M | M.2 Key E 2230 |
| N | CMOS Battery Holder |
| O | BIOS Security Jumper |

2.1.3 Tall Chassis Layout (I/O Ports)

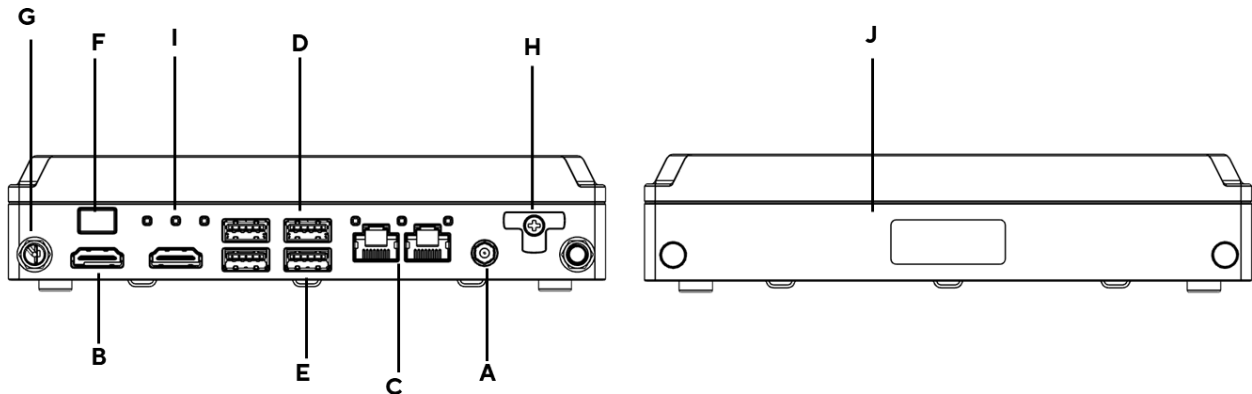

Figure 3. Tall Chassis Layout – NUC 13 Rugged Kit

Table 8. Shown in Figure 3 Tall Chassis I/O Ports Description

| Item from Figure 3 | Description |
|--------------------|--|
| A | 12-20 V DC Input Jack |
| B | HDMI 2.1 TMDS Port 1 with Built-In CEC Support |
| C | LAN Connectors |
| D | Back Panel 2 USB 3.2 Gen 2 |
| E | Back Panel 2 USB 2.0 |
| F | Power Button |
| G | Antenna Connection |
| H | Cable Locking Arm |
| I | LEDs |
| J | Front Chassis image |

2.1.4 Slim Chassis Layout (I/O Ports)

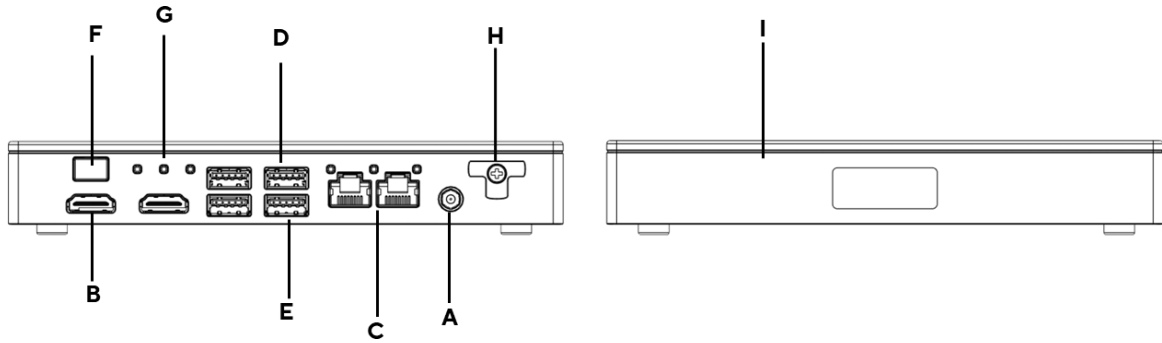

Figure 4. Slim Chassis Layout – NUC 13 Rugged Kit

Table 9. Shown in Figure 4. Slim Chassis I/O Ports Description

| Item from Figure 4 | Description |
|--------------------|--|
| A | 12-20 V DC Input Jack |
| B | HDMI 2.1 TMDS Port 1 with Built-In CEC Support |
| C | LAN Connector |
| D | Back Panel 2 USB 3.2 Gen 2 |
| E | Back Panel 2 USB 2.0 |
| F | Power Button |
| G | LEDs |
| H | Cable Locking Arm |
| I | Front Chassis image |

2.1.5 Chassis Expandability Options

The chassis side panel of the ASUS NUC Rugged NUC13BR Boards and Kits Canyon supports an opening for 3rd party / customer expandability option. This expandability bay usage is not limited to, Camera connections, etc. The chassis provides a plastic face plate for covering the side panel opening when no expansion is installed. The Face plate matches the chassis color and texture.

Some 3rd party expandability dongles are available from <https://gorite.com> and a specification is available for the design of 3rd party add in cards. This is the shipping configuration:

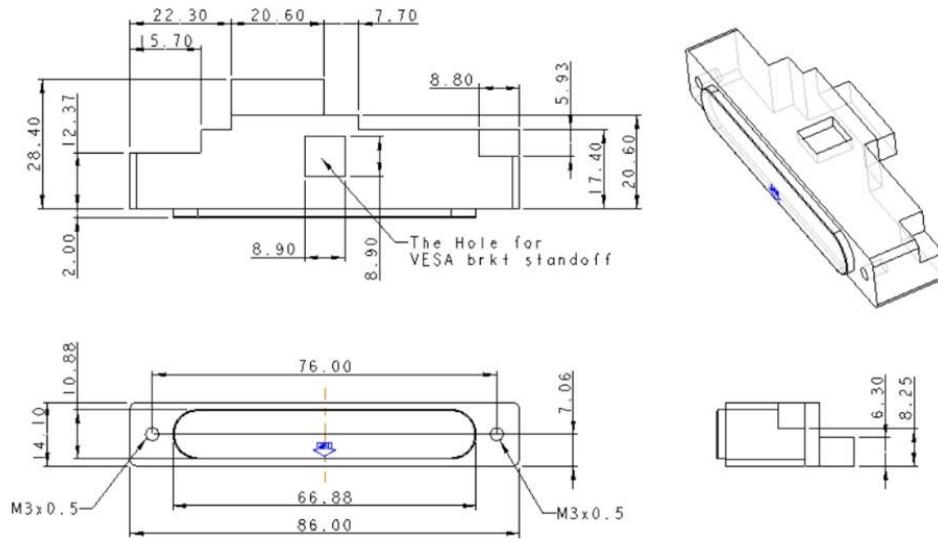

Figure 5. Tall Chassis Side Panel Expansion Slot

2.2 Processor Support Features

Several of the featured technologies in the 13th Gen platform are designed to support industrial and telecommunications applications that demand more reliability, bounded-latency workloads, and robust wireless connectivity. Select SKUs of 13th Gen Intel® processors support:

- Intel® Time Coordinated Computing (TCC)
- Time- Sensitive Networking (TSN) capability with integrated, real-time-capable 2x 2.5GbE connections. This is supported on i226-LM SKUs only.

Select SKUs also bring support for embedded use conditions and discrete Intel® Wi-Fi 6E connectivity. These featured technologies are especially useful where wired connections or physical access to a device is otherwise inconvenient or costly.

Table 10. TCC/TSN Feature support per processor

| Processor | TCC | TSN | i226-LM | i226-V | Comments |
|------------------------------------|-----|-----|---------|--------|--|
| Intel® Processor N50 (Config A) | NO | NO | NO | YES | N50 processor does not support TCC/TSN and Config A does not come with i226-LM LAN controller |
| Intel® Processor X7211E (Config B) | YES | NO | NO | YES | x7211E processor supports TCC but not TSN. Config A comes with i226-V LAN controller, so TCC is supported. |
| Intel® Processor X7245E (Config C) | YES | YES | YES | NO | x7245E processor and Config C come with i226-LM controller. Therefore, both TSN and TCC are supported. |

2.3 Processor Graphics Subsystem

The ASUS NUC 13 Rugged Kits NUC13BRK and NUC13BRF supports graphics through the Intel® UHD 770 Graphics for 13th Gen Intel® Processors including: Intel® Processor N50 and Intel Atom® Processors (X7211E and X7425E).

Integrated graphics support features through Intel® Graphics Technology includes but not limited to the following:

- Supports up to dual 4K@60Hz display or dual 1080@60Hz (2 x HDMI 2.1 TMDS)
- HDR (High Dynamic Range) support
- Dual display pipes – supporting blending, color adjustments, scaling, and dithering.
- Support for HDCP 2.3
- Codecs supported are detailed on <https://www.asus.com/support/Download-Center/>
- Support Headless, 2nd Virtual Display and Persistent Display Mode Operation
- Accelerate Video Processing for Visual Experiences, Video Walls, and Graphics- Intensive Apps

Integrated graphics create new opportunities for visually rich experiences and graphics-enhanced controls while reducing dependency on discrete graphics hardware. 13th Gen Intel® Core™ processors featuring Intel® UHD Graphics 770 driven by Intel® Xe architecture⁴—with up to 16 graphics execution units (EUs) for N50 Processor, x7211E Processor and 24 graphics execution units for X7425E Processor, — deliver fast graphics performance. Three display pipes of 4K 60Hz HDR video, up to three multiformat codec (MFX) engines—up to 2x video decode and 1x video encode—and Genlock and Pipelock support video walls, digital signage, and processing for multiple video streams.

For information about...

Intel Graphics Technologies

Refer to:

<http://www.intel.com/graphics>

2.3.1 Display Emulation

Display emulation is supported using the HDMI ports so that the system may be remotely accessed in a headless configuration or be capable of tolerating display connectivity interruptions without the operating system redetecting and rearranging the overall display layout. The display emulation feature may be enabled in BIOS Setup with the following checkboxes:

- “Virtual display emulation”: provides a 1280x1024 virtual display when no displays are connected to the system and provides an additional 1280x1024 virtual display if one display is attached to the system. If two displays are attached to the HDMI ports, these displays are enabled, and no virtual displays are provided.
- “Persistent display emulation”: emulates that both displays are always connected to the system no matter their actual connection status. The EDID information from each display remains programmed through Modern Standby, S4, S5 and G3 power states until the feature is disabled.
- When “Persistent display emulation” is enabled another drop-down menu (“Inconsistent Display Device”) becomes visible that allows the user to select the behavior of the system when the display device EDID is inconsistent with the EDID stored by the system.
 - “Block boot” (default selection): the BIOS displays a warning message with options and waits indefinitely for a user selection.
 - “Countdown”: the BIOS displays a warning message with options and waits 10 seconds before booting.

2.3.2 High-Definition Multimedia Interface* (HDMI*)

The HDMI port is HDMI 2.1 TMDS compatible specification compliant and support standard, enhanced, or high-definition video, plus multi-channel digital audio on a single cable. The port is compatible with all ATSC and DVB HDTV standards and supports thirty-two full range channels of lossless audio formats.

For information about

HDMI technology

Refer to

<http://www.hdmi.org>



NOTE

When using “Persistent display emulation” it would be expected behavior for the system not to properly drive displays different than those connected when the feature was enabled, as the EDID parameters of the initially connected displays are still being driven by the system. In order to retrain the system for different displays, the persistent display emulation feature must be disabled in the BIOS, the system rebooted, and then the persistent display emulation feature must be reenabled.

2.3.3 NVMe/SATA Interfaces

The PCH provides three Internal M.2 interface slots with a theoretical maximum transfer rate and provides the following interfaces:

- M.2 #1 22x80 supports up to 3.5 Gb/s with one PCIe M.2 slot for SSD and AI accelerator use. The M.2 SSD slot is required to support NVMe drives.
- M.2 #2 22x30 support up to 2.4 Gb/s with one M.2 slot for wireless card expandability. L10 SKU is equipped with a wireless card pre-installed. However, board SKUs have an empty slot.
- M.2 #3 30x42 up to 6 Gb/s is designed to have one 30x42 B-keyed M.2 slot which is used for WWAN, SATA, NVMe (NVMe x2 running as NVMe x1 only) and AI accelerator expansion module.



NOTE

Bravo Canyon is not equipped with a 2.5” SATA Drive Bay.

2.3.4 Real-Time Clock Subsystem

A coin-cell battery (CR2032) powers the real-time clock and CMOS memory. When the computer is not plugged into a wall socket, the battery has an estimated life of three years. When the computer is plugged in, the standby current from the power supply extends the life of the battery. The clock is accurate to 13 minutes/year at 25 °C with 3.3 VSB applied via the power supply 5 V STBY rail.



NOTE

If the battery and AC power fail, date and time values are reset and the user is notified during the POST.

When the voltage drops below a certain level, the BIOS Setup program settings stored in CMOS RAM (for example, the date and time) might not be accurate. Replace the battery with an equivalent one.

System can power on from G3/AC power loss state without the Real-Time Clock battery.

2.4 LAN Subsystem

2.4.1 RJ-45 LAN Connector with Integrated LEDs

Two LEDs are built into the RJ-45 LAN connector (shown in **Figure 6**. LAN Connectors Location).

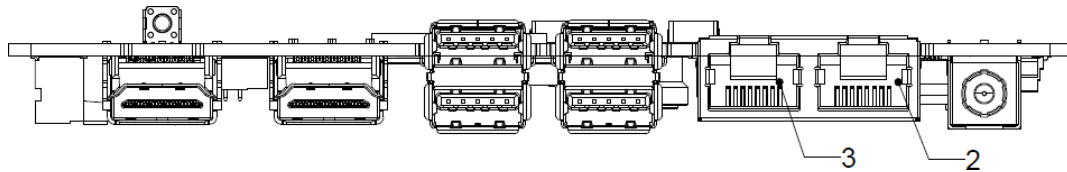

| Item | Description |
|------|-----------------|
| A | LAN Connector 2 |
| B | LAN Connector 3 |

Figure 6. LAN Connectors Location

Table 12 describes the LED states when the board is powered up and the LAN subsystem is operating.

Table 11. LAN Connector LED States

| LED | LED Color | LED State | Condition |
|-----------|--------------|-----------|-----------------------------------|
| Link | Green | Off | LAN link is not established |
| | | Solid | LAN link is established |
| | | Blinking | LAN activity is occurring |
| Data Rate | Green/Yellow | Off | 10/100 Mb/s data rate is selected |
| | | Yellow | 1000 Mb/s data rate is selected |
| | | Green | 2500 Mb/s data rate is selected |

2.5 MIPI CSI Interfaces

2.5.1 The pin out of the multiple MIPI headers

| 0.5mm FPC Camera Header | | | |
|-------------------------------|---------|--------------|---------------------|
| Function | NUC Pin | Description | Note |
| MIPI CSI-2 Signals | 1 | GND | |
| | 2 | CSI_DAT0_N | |
| | 3 | CSI_DAT0_P | |
| | 4 | GND | |
| | 5 | CSI_DAT1_N | |
| | 6 | CSI_DAT1_P | |
| | 7 | GND | |
| | 8 | CSI_CLK_N | |
| | 9 | CSI_CLK_P | |
| | 10 | GND | |
| | 11 | CSI_DAT2_N | |
| | 12 | CSI_DAT2_P | |
| | 13 | GND | |
| | 14 | CSI_DAT3_N | |
| | 15 | CSI_DAT3_P | |
| | 16 | GND | |
| | 17 | CSI_CLK_N | |
| | 18 | CSI_CLK_P | |
| | 19 | GND | |
| Driver Defined GPIO Functions | 20 | PWM1 / GPIO1 | 1.8v PCH PWM1/GPIO1 |
| | 21 | PWM2 / GPIO2 | 1.8v PCH PWM2/GPIO2 |
| | 22 | GPIO3 | 1.8v PCH GPIO3 |
| | 23 | GPIO4 | 1.8v PCH GPIO4 |
| | 24 | CLK1 / GPIO5 | 1.8v PCH CLK1/GPIO5 |
| | 25 | CLK2 / GPIO6 | 1.8v PCH CLK2/GPIO6 |
| | 26 | GND | |
| I2C | 28 | I2C_SDA | 1.8v LVTT/LVCMOS |
| | 29 | I2C_SCL | 1.8v LVTT/LVCMOS |
| Cam PWR | 27 | Vcc3V3 | 0.5A |
| | 30 | Vcc3V3 | 0.5A |

Figure 7. PIN Out of MIPI Headers

2.5.2 Enable the MIPI CSI Interfaces in BIOS Menu

To enable the MIPI CSI Interfaces, users need to modify BIOS configurations in BIOS setup menu following below instructions.

1. Enable IPU Device and 1181 Dash Camera in BIOS menu -> Advanced -> MIPI Camera.



2. Configure camera **HID** and **GPIO** settings in BIOS menu -> Advanced -> MIPI Camera -> Slot1 or Slot2. Default camera settings are for **INTC10C0** and **IMX415** cameras.



3. If 3rd party camera modules are used, users need to customize camera **HID** and **GPIO** settings in BIOS menu -> Advanced -> MIPI Camera -> Slot1 or Slot2.



2.6 Hardware Management Subsystem

2.6.1 Fanless Thermal Solution

The chassis is required to be fanless, thermally and environmentally robust in lower air-quality environments (i.e., dust, 40°C ambience, etc.). Bravo will not be used outdoors.

Fan-less thermal solution meets these requirements:

- The chassis and thermal solution are designed so all system configurations do not exceed 70C skin temp at 35C ambient.
- We can exceed 70C skin temperature at higher ambience. Some SKUs have been tested at 40C and 50C for respective configurations as defined by the PRD workloads.
- Warning labels and or notifications are provided to customers if skin temps exceeding 80C under ambient conditions > 35C.

2.6.2 System States and Power States

Table 13 describes the ACPI states supported by the processor.

2.6.3 Wake-up Devices and Events

Lists devices or specific events that can wake the computer from specific states.

Bravo Canyon must support the wake-up events listed below. Note that S4 implies OS support only.

Table 12. LAN Wake Events

| Wake-Up Event | State from Sleep |
|---------------|------------------------|
| Power button | Modern Standby, S4, S5 |
| RTC alarm | Modern Standby, S4, S5 |
| LAN | Modern Standby, S5 |
| USB | Modern Standby, S4, S5 |
| PCIe | Modern Standby, S4 |
| Bluetooth | Modern Standby, S4 |
| Wi-Fi | Modern Standby, S4, S5 |
| WWAN | Modern Standby, S4, S5 |



NOTE

The use of these wake-up events from an ACPI state requires an operating system that provides full ACPI support. In addition, software, drivers, and peripherals must fully support ACPI wake events.

2.6.4 Signal Tables for the Connectors and Headers

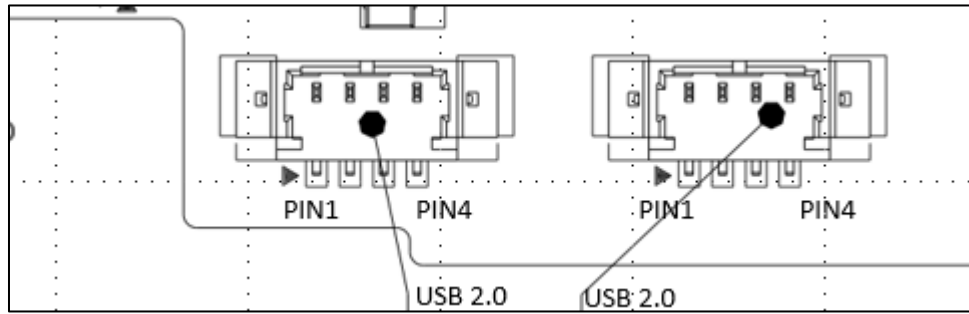

Figure 8. USB Header PIN Layout

Table 13. Internal USB 2.0 Headers (1.25 mm pitch)

| Pin | Signal Name |
|-----|------------------|
| 1 | 5 V ¹ |
| 2 | D - |
| 3 | D + |
| 4 | GND |

¹The two USB 2.0 headers on the board can deliver 1A per port.

Connector is Molex part number 53398-0471, 1.25mm Pitch PicoBlade* Header, Surface Mount, Vertical, Lead-Free, 4 Circuits.

Table 14. M.2 2280 Module (Mechanical Key M) Connector

| # | Requirement | Details | | | |
|---|-----------------------------|---|----------------------------------|-----|--------------------------|
| 1 | Slot form Factor | 22x80 | | | |
| 2 | Number of Slots | 3 | | | |
| 3 | SSD Support | PCIe Gen4 NVMe | | | |
| 4 | Slot Type | Socket 3, key M; Must meet Gold plating requirements in 2.6.28 | | | |
| 5 | Slot Post and screw | Post w/Philips-head screw installed @ 80mm Torque for post in 80mm solder nut: 2.5±0.5 in-lbs Torque for screw in post: Must be slightly less than torque setting above. Unscrewing screw from post must not cause post to loosen. Screw is to have ferromagnetic properties for ease of assembly. | | | |
| 6 | Power Delivery Requirement | 3.3VDC @ 3.5A nominal, 7.0A peak | | | |
| 7 | Slot Signals | Pin | Signal Name | Pin | |
| | | | Signal Name | | |
| | | 74 | 3.3V | 75 | GND |
| | | 72 | 3.3V | 73 | GND |
| | | 70 | 3.3V | 71 | GND |
| | | 68 | SUSCLK(32kHz)(O)(0/3.3V) | 69 | PEDET (NC-PCIe/GND-SATA) |
| | | 66 | Connector Key | 67 | N/C |
| | | 64 | Connector Key | 65 | Connector Key |
| | | 62 | Connector Key | 63 | Connector Key |
| | | 60 | Connector Key | 61 | Connector Key |
| | | 58 | N/C | 59 | Connector Key |
| | | 56 | N/C | 57 | GND |
| | | 54 | PEWAKE# (I/O)(0/3.3V) or N/C | 55 | REFCLKP |
| | | 52 | CLKREQ# (I/O)(0/3.3V) or N/C | 53 | REFCLKN |
| | | 50 | PERST# (O)(0/3.3V) or N/C | 51 | GND |
| | | 48 | N/C | 49 | PETp0 |
| | | 46 | N/C | 47 | PETn0 |
| | | 44 | N/C | 45 | GND |
| | | 42 | N/C | 43 | PERp0 |
| | | 40 | N/C | 41 | PERn0 |
| | | 38 | DEVSLP (O) | 39 | GND |
| | | 36 | N/C | 37 | PETp1 |
| | | 34 | N/C | 35 | PETn1 |
| | | 32 | N/C | 33 | GND |
| | | 30 | N/C | 31 | PERp1 |
| | | 28 | N/C | 29 | PERn1 |
| | | 26 | N/C | 27 | GND |
| | | 24 | N/C | 25 | N/C |
| | | 22 | N/C | 23 | N/C |
| | | 20 | N/C | 21 | GND |
| | | 18 | 3.3V | 19 | N/C |
| | | 16 | 3.3V | 17 | N/C |
| | | 14 | 3.3V | 15 | GND |
| | | 12 | 3.3V | 13 | N/C |
| | | 10 | DAS/DSS# (I/O)/LED1# (I)(O/3.3V) | 11 | N/C |
| | | 8 | PLN | 9 | GND |
| | | 6 | N/C | 7 | N/C |
| | | 4 | 3.3V | 5 | N/C |
| | | 2 | 3.3V | 3 | GND |
| | | | | 1 | GND |
| 8 | iRST PCIe Remapping support | Required | | | |

Table 15. M.2 2230 Module (Mechanical Key E) Connector

| # | Requirement | Details | | | |
|---|----------------------------|---|---|-----|------------------------|
| 1 | Slot form Factor | M.2 22x30 - http://www.pcisig.com/members/downloads/PCIe M.2 Electromechanical Spec Rev1.0 Final 11012013 RS Clean.pdf | | | |
| 2 | Number of Slots | 1 | | | |
| 3 | Slot Type | Key "E" must meet Gold plating requirements in section 2.6.28. | | | |
| 4 | Slot Nut, Post | 1x solder nut installed @ 30mm position, pre-installed with 1x post w/wireless card installed in the 22x30 slot. | | | |
| 5 | Power Delivery Requirement | 3.3V _{DC} @ 2.75A | | | |
| 6 | Slot Signals | Pin | Signal Name | Pin | Signal Name |
| | | 74 | 3.3V | 75 | GND |
| | | 72 | 3.3V | 73 | WT_CLKP |
| | | 70 | UIM_POWER_SRC/GPIO1/PEWAKE1# | 71 | WT_CLKN |
| | | 68 | CLKREQ1# | 69 | GND |
| | | 66 | PERST1# | 67 | WTDOP |
| | | 64 | REFCLK0 | 65 | WTDON |
| | | 62 | ALERT#/A4WP_IRQ# (I)(0/3.3) | 63 | GND |
| | | 60 | I2C_CLK/A4WP_I2C_CLK (O)(0/3.3) | 61 | WT_DIP |
| | | 58 | I2C_DATA/A4WP_I2C_DATA (I/O)(0/3.3) | 59 | WT_DIN |
| | | 56 | W_DISABLE1# (O)(0/3.3V) | 57 | GND |
| | | 54 | W_DISABLE2# (O)(0/3.3V) | 55 | PEWAKE0# (I/O)(0/3.3V) |
| | | 52 | PERST0# (O)(0/3.3V) | 53 | CLKREQ0# (I/O)(0/3.3V) |
| | | 50 | SUSCLK(32kHz) (O)(0/3.3V) | 51 | GND |
| | | 48 | COEX1 (I/O)(0/1.8V) | 49 | REFCLKN0 |
| | | 46 | COEX2(I/O)(0/1.8V) | 47 | REFCLKP0 |
| | | 44 | COEX3(I/O)(0/1.8V) | 45 | GND |
| | | 42 | CLink_CLK (I/O); NC for SR project | 43 | PERn0 |
| | | 40 | CLink_DATA (I/O); NC for SR project | 41 | PERp0 |
| | | 38 | C-Link RESET* (I) (0/3.3V); NC for SR project | 39 | GND |
| | | 36 | UART RTS/BRI_DT (I) (0/1.8V) | 37 | PETn0 |
| | | 34 | UART CTS (O) (0/1.8V) | 35 | PETp0 |
| | | 32 | UART TXD/RGI_DT (I) (0/1.8V) | 33 | GND |
| | | 30 | Connector Key | 31 | Connector Key |
| | | 28 | Connector Key | 29 | Connector Key |
| | | 26 | Connector Key | 27 | Connector Key |
| | | 24 | Connector Key | 25 | Connector Key |
| | | 22 | UART RXD/BRI_RSP (O) (0/1.8V) | 23 | WGR_CLKP |
| | | 20 | UART WAKE# (O) (0/3.3V) | 21 | WGR_CLKN |
| | | 18 | GND/LNA_EN | 19 | GND |
| | | 16 | LED2# | 17 | WGR_DOP |
| | | 14 | PCM_OUT/I2SSD_OUT/CLKREQ0 | 15 | WGR_DON |
| | | 12 | PCM_IN/I2SSD_IN | 13 | GND |
| | | 10 | PCM_SYNC/I2SWS/RF_RESET_B | 11 | WGR_DIP |
| | | 8 | PCM_CLK/I2SSCK | 9 | WGR_DIN |
| | | 6 | LED1# | 7 | GND |
| | | 4 | 3.3V | 5 | USB_D- |
| | | 2 | 3.3V | 3 | USB_D+ |
| | | | | 1 | GND |

Table 16. M.2 30x42 Module (Mechanical Key B) Connector

Bravo Canyon has one M.2 30x42 slot for wireless card expandability that's pre-installed. See section 3.6.3.1 for additional detailed information.

| | | | |
|----|--|---------------------------|----|
| 74 | 3.3V | CONFIG_2 | 75 |
| 72 | 3.3V | GND | 73 |
| 70 | 3.3V | GND | 71 |
| 68 | SUSCLK(32kHz) (O)(0/3.3V) | CONFIG_1 | 69 |
| 66 | SIM DETECT (O) | RESET# (O)(0/1.8V) | 67 |
| 64 | COEX1 (I/O)(0/1.8V) | ANTCTL3 (I)(0/1.8V) | 65 |
| 62 | COEX2(I/O)(0/1.8V) | ANTCTL2 (I)(0/1.8V) | 63 |
| 60 | COEX3(I/O)(0/1.8V) | ANTCTL1 (I)(0/1.8V) | 61 |
| 58 | N/C | ANTCTL0 (I)(0/1.8V) | 59 |
| 56 | N/C | GND | 57 |
| 54 | PEWAKE# (I/O)(0/3.3V) | REFCLKP | 55 |
| 52 | CLKREF0# (I/O)(0/3.3V) | REFCLKN | 53 |
| 50 | PERST# (O)(0/3.3V) | GND | 51 |
| 48 | GPIO_4 (I/O)(0/1.8V*) | PETp0/SATA-A+ | 49 |
| 46 | GPIO_3 (I/O)(0/1.8V*) | PETn0/SATA-A- | 47 |
| 44 | GPIO_2 (I/O)(0/1.8V*) | GND | 45 |
| 42 | GPIO_1 (I/O)(0/1.8V*) | PERp0/SATA-B- | 43 |
| 40 | GPIO_0 (I/O)(0/1.8V*) | PERn0/SATA-B+ | 41 |
| 38 | DEVSLP (O) | GND | 39 |
| 36 | UIM-PWR (I) | PETp1/USB3.0-Tx+/SSIC-TxP | 37 |
| 34 | UIM-DATA (I/O) | PETn1/USB3.0-Tx-/SSIC-TxN | 35 |
| 32 | UIM-CLK (I) | GND | 33 |
| 30 | UIM-RESET (I) | PERp1/USB3.0-Rx+/SSIC-RxP | 31 |
| 28 | GPIO_8 (I/O) (0/1.8V) | PERn1/USB3.0-Rx-/SSIC-RxN | 29 |
| 26 | GPIO_10 (I/O)(0/1.8V) | GND | 27 |
| 24 | GPIO_7 (I/O) (0/1.8V) | DPR (O) (0/1.8V) | 25 |
| 22 | GPIO_6 (I/O)(0/1.8V) | GPIO_11 (I/O) (0/1.8V) | 23 |
| 20 | GPIO_5 (I/O)(0/1.8V) | CONFIG_0 | 21 |
| | Connector Key | Connector Key | |
| | Connector Key | Connector Key | |
| | Connector Key | Connector Key | |
| | Connector Key | Connector Key | |
| | Connector Key | Connector Key | |
| 10 | GPIO_9/DAS/DSS# (I/O)/LED1#(I)(0/3.3V) | GND | 11 |
| 8 | W_DISABLE1# (O)(0/3.3V) | USB_D- | 9 |
| 6 | FULL_CARD_POWER_OFF# (O)(0/1.8V or 3.3V) | USB_D+ | 7 |
| 4 | 3.3V | GND | 5 |
| 2 | 3.3V | GND | 3 |
| | | CONFIG_3 | 1 |

2.6.5 M.2 30x42 Pin-Out (Mechanical Key B) detail info

- Socket 2 pinout is intended to support WWAN+GNSS, SSD, and other types of Add-In solutions with the defined and configurable Host I/Fs.
- WWAN can make use of USB2.0, USB3.0, PCIe (up to two Lanes), or SSIC host I/Fs. The actual implemented I/F is identified through the Configuration pins state (1 of 16 states) on the Module side. LED1# and W_DISABLE1# are intended for use with the WWAN solution. There are additional WWAN and GNSS related pins including W_DISABLE2#, DPR, and WAKE_ON_WWAN#
- The UIM and SIM Detect pin are used in conjunction with a SIM device in support of the WWAN solution.
- The COEX and ANTCTL pins are placeholders for future expansion and definition of these functions.
- The GPIO 11 pins are configurable with four different variants. These variants can be in support of the GNSS interface, second UIM/SIM, Audio interfaces, HSIC and IPC sidebands. The exact definition is determined by which configuration was identified by decoding the four Configuration pins.
- The FULL_CARD_POWER_OFF# and the RESET# pins are unique and intended to be used when the WWAN solution is plugged into platforms that provide a direct connection to **VBATT** (and not a regulated 3.3 V) such as Tablet platforms. They are not used in NB and Very thin notebooks type platforms that provide a regulated 3.3 V power rail. But the FULL_CARD_POWER_OFF# signals should be tied to the 3.3V power rail on the NB/very thin platform.
- The SSD can make use of the PCIe two Lanes or overlaid SATA host I/F. The actual implemented I/F is identified through the CONFIG_1 pin state (1 or 0) in conjunction with the other three Configuration pin states that are all 0. DAS/DSS# (overlaid on the LED1#) and DEVSLP are intended for use with the SATA SSD solution.
- The SUSCLK pin provides a Slow Clock signal of 32 kHz to enable Low Power States.
- Pins labeled N/C should Not Be Connected.

2.6.6 Back Panel Header (2.0 mm Pitch)

This section describes the functions of the front and back panel headers.

Table 17. Back Panel Header (2.0 mm pitch)

| Pin | Signal Name | Description | Pin | Signal Name | Description |
|-----|-------------------|--------------------------|-----|----------------|--|
| 1 | HDD_POWER_LED | Pull-up 750Ω to +5V | 2 | POWER_LED_MAIN | [Out] Front panel LED (main color) Pull-up 300Ω to +5V |
| 3 | HDD_LED# | [Out] HDD activity LED | 4 | POWER_LED_ALT | [Out] Front panel LED (alt color) |
| 5 | GROUND | Ground | 6 | POWER_SWITCH# | [In] Power switch |
| 7 | RESET_SWITCH# | [In] Reset switch | 8 | GROUND | Ground |
| 9 | +5V_DC (1A) (Vcc) | VCC5 (1A current rating) | 10 | Key | No pin |
| 11 | 5Vsby (2A) | 5VSB (2A current rating) | 12 | 3.3Vsby (1A) | 3VSB (1A current rating) |

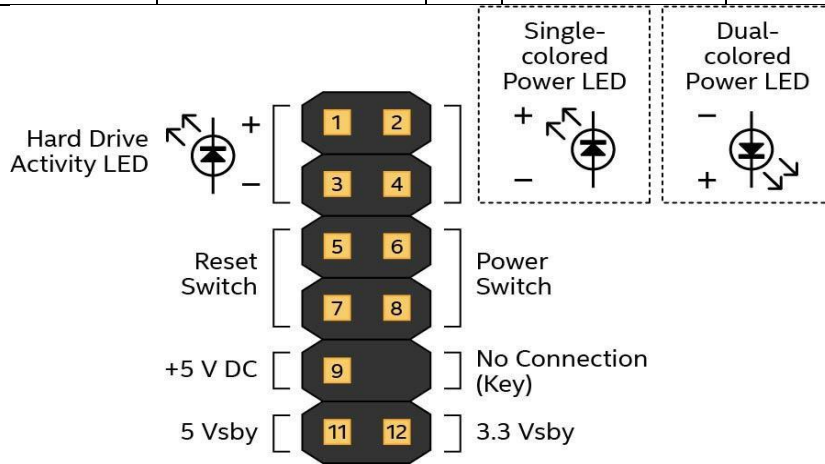

Figure 9. Connection Diagram for Front Panel Header (2.0 mm Pitch)

2.6.6.1 Hard Drive Activity LED Header

Pins 1 and 3 can be connected to an LED to provide a visual indicator that data is being read from or written to a hard drive. Proper LED function requires a SATA hard drive or optical drive connected to an onboard SATA connector.

2.6.6.2 Reset Switch Header

Pins 5 and 7 can be connected to a momentary single pole, single throw (SPST) type switch that is normally open. When the switch is closed, the board resets and runs the POST.

2.6.6.3 Power/Sleep LED Header

Pins 2 and 4 can be connected to a one- or two-color LED. **Table 21** and **Table 22** show the possible LED states.

Table 18. States for a One-Color Power LED

| LED State | Description |
|-----------|------------------|
| Off | Power off |
| Blinking | Standby |
| Steady | Normal operation |

Table 19. States for a Dual-Color Power LED

| LED State | Description |
|------------------|------------------|
| Off | Power off |
| Blinking (white) | Standby |
| Steady (white) | Normal operation |



NOTE

The LED behavior shown in is default – other patterns may be set via BIOS setup.

2.6.6.4 Power Switch Header

Pins 6 and 8 can be connected to a front panel momentary-contact power switch. The switch must pull the SW_ON# pin to ground for at least 50 ms to signal the power supply to switch on or off (the time requirement is due to internal debounce circuitry on the board). At least two seconds must pass before the power supply recognizes another on/off signal.

2.6.6.5 BIOS Security Jumper



CAUTION

Do not move a jumper with the power on. Always turn off the power and unplug the power cord from the computer before changing the jumper setting. Otherwise, the board could be damaged.

Figure 10: Shows the location of the BIOS Security Jumper. The Pins1&2 and Pins 2&3 jumpers determine the BIOS Security program's mode.

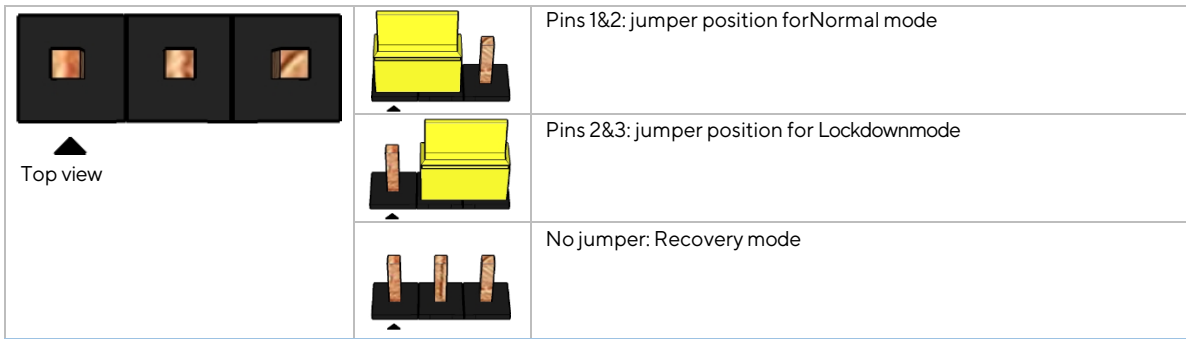

Figure 10. BIOS Security Jumper Header

Table 21 describes the jumper settings for the three modes: normal, lockdown, and configuration.

Table 20. BIOS Security Jumper Settings

| Function/Mode | Jumper Setting | Configuration |
|---------------|----------------|---|
| Normal | 1-2 | The BIOS uses current configuration information and passwords for booting. |
| Lockdown | 2-3 | The BIOS uses current configuration information and passwords for booting, except: <ul style="list-style-type: none"> All POST Hotkeys are suppressed (prompts are not displayed and keys are not accepted. For example, F2 for Setup, F10 for the Boot Menu). Power Button Menu is not available (see Section 3.6.3.2 Power Button Menu). BIOS updates are not available except for automatic Recovery due to flash corruption. |
| Configuration | None | BIOS Recovery Update process if a matching *.bio file is found. Recovery Update can be cancelled by pressing the Esc key. If the Recovery Update was cancelled or a matching *.bio file was not found, a Config Menu is displayed. The Config Menu consists of the following (followed by the Power Button Menu selections): <ul style="list-style-type: none"> [1] Suppress this menu until the BIOS Security Jumper is replaced. [2] Clear BIOS User and Supervisor Passwords. [3] Reset ASUS AMT to default factory settings. [F2] ASUS Visual BIOS. [F4] BIOS Recovery. See Section 4.3.2 Power Button Menu |



NOTE The ASUS NUC Rugged NUC13BR Boards and Kits do not support discrete TPM.

2.6.6.6 Power Supply Connectors



NOTE External power voltage, 12-20 ($\pm 5\%$) V DC, is dependent on the type of power supply used. System power requirements depend on actual system configurations chosen by the integrator, as well as end user expansion preferences. It is the system integrator's responsibility to ensure an appropriate power budget for the system configuration is properly assessed based on the system-level components chosen.



CAUTION

There is no isolation circuitry between the external DC jack and the internal 2 x 2 power connector. It is the system integrator's responsibility to ensure no more than one power supply unit is or can be attached to the board at any time and to ensure the external DC jack is covered if the internal 2 x 2 power connector is to be used. Simultaneous connection of both external and internal power supply units could result in potential damage to the board, power supplies, or other hardware.

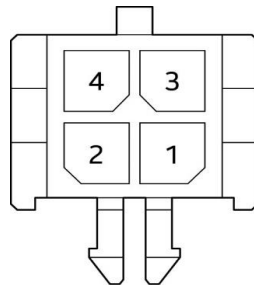

OM24146

Table 21. Internal Power Supply Connector Pins

| Pins | Signal Name |
|------|-------------|
| 1,2 | +12-20V |
| 3,4 | GND |

The board has the following power supply connectors:

- **External Power Supply** – the board can be powered through a 12-20 V DC connector on the back panel. The back-panel DC connector is compatible with a 5.5 mm/OD (outer diameter) and 2.5 mm/ID (inner diameter) plug, where the inner contact is +12-20 V DC, and the shell is GND. The maximum current rating is 10 A.
- **Internal Power Supply** – the board can alternatively be powered via the internal 12-20 V DC 2 x 2 power connector, where pins 1 and 2 are +12-20 V DC and pins 3 and 4 are GND. The maximum current rating is 10 A (5A per pins 1 and 2).

The connector used is Molex Micro-Fit (3mm pitch), right-angled, 4-pos/dual row (2x2).

Table 23 describes the jumper settings for the three modes: normal, lockdown, and configuration.

Table 22. BIOS Security Jumper Settings

| Function/Mode | Jumper Setting | Configuration |
|---------------|----------------|--|
| Normal | 1-2 | The BIOS uses current configuration information and passwords for booting. |
| Lockdown | 2-3 | The BIOS uses current configuration information and passwords for booting, except: <ul style="list-style-type: none"> • All POST Hotkeys are suppressed (prompts are not displayed and keys are not accepted. For example, F2 for Setup, F10 for the Boot Menu). • Power Button Menu is not available (see Section 3.6.3.2 Power Button Menu). BIOS updates are not available except for automatic Recovery due to flash corruption. |
| Configuration | None | BIOS Recovery Update process if a matching *.bio file is found. Recovery Update can be cancelled by pressing the Esc key. If the Recovery Update was cancelled or a matching *.bio file was not found, a Config Menu is displayed. The Config Menu consists of the following (followed by the Power Button Menu selections): <ul style="list-style-type: none"> [4] Suppress this menu until the BIOS Security Jumper is replaced. [5] Clear BIOS User and Supervisor Passwords. [6] Reset ASUS AMT to default factory settings. [F2] ASUS Visual BIOS. [F4] BIOS Recovery. See Section 4.3.2 Power Button Menu |



NOTE The ASUS NUC Rugged NUC13BR Boards and Kits do not support discrete TPM.

2.6.6.7 Power Supply Connectors



NOTE External power voltage, 12-20 ($\pm 5\%$) V DC, is dependent on the type of power supply used. System power requirements depend on actual system configurations chosen by the integrator, as well as end user expansion preferences. It is the system integrator's responsibility to ensure an appropriate power budget for the system configuration is properly assessed based on the system-level components chosen.



CAUTION

There is no isolation circuitry between the external DC jack and the internal 2 x 2 power connector. It is the system integrator's responsibility to ensure no more than one power supply unit is or can be attached to the board at any time and to ensure the external DC jack is covered if the internal 2 x 2 power connector is to be used. Simultaneous connection of both external and internal power supply units could result in potential damage to the board, power supplies, or other hardware.

The board has the following power supply connectors:

- **External Power Supply** – the board can be powered through a 12-20 V DC connector on the back panel. The back-panel DC connector is compatible with a 5.5 mm/OD (outer diameter) and 2.5 mm/ID (inner diameter) plug, where the inner contact is +12-20 V DC, and the shell is GND. The maximum current rating is 10 A.
- **Internal Power Supply** – the board can alternatively be powered via the internal 12-20 V DC 2 x 2 power connector, where pins 1 and 2 are +12-20 V DC and pins 3 and 4 are GND. The maximum current rating is 10 A (5A per pins 1 and 2).

The connector used is Molex Micro-Fit (3mm pitch), right-angled, 4-pos/dual row (2x2).

2.7 Mechanical Considerations

2.7.1 Chassis Images

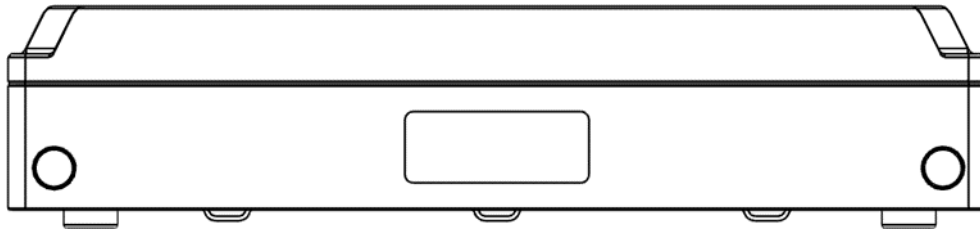

Figure 11. Tall Chassis Image Front

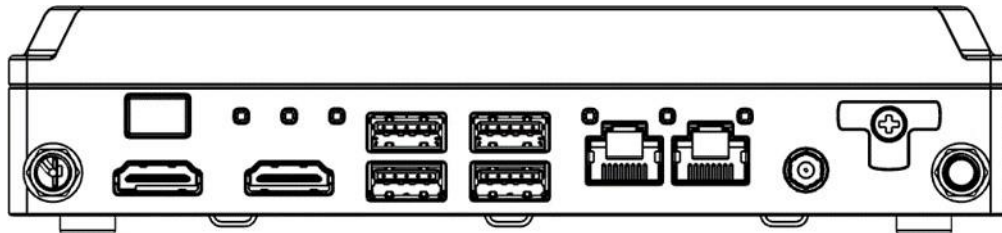

Figure 12. Tall Chassis Image Back



Figure 13. Short Chassis Image Front

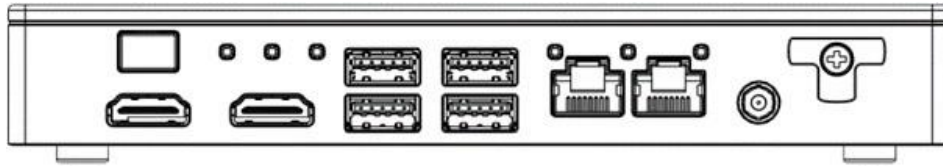

Figure 14. Short Chassis Image Back

2.7.2 Thermal Considerations



CAUTION

Failure to ensure appropriate airflow may result in reduced performance of both the processor and/or voltage regulator or, in some instances, damage to the board.

All responsibility for determining the adequacy of any thermal or system design remains solely with the system integrator. ASUS makes no warranties or representations that merely following the instructions presented in this document results in a system with adequate thermal performance.



CAUTION

Ensure that the ambient temperature does not exceed the board's maximum operating temperature. Failure to do so could cause components to exceed their maximum case temperature and malfunction. For information about the maximum operating temperature, see the environmental specifications in Section 3.10.



CAUTION

Ensure that proper airflow is maintained in the processor voltage regulator circuit. Failure to do so may result in a shorter than expected product lifetime.

2.7.3 Reliability

The demonstrated Mean Time Between Failures (MTBF) for NUC13BR is TBD.

2.8 Environmental

Table 24 lists the environmental specifications for the board.



CAUTION

If the external ambient temperature exceeds 50 °C, further thermal testing is required to ensure components do not exceed their maximum operating temperature.

Table 23. Environmental Specifications

| Parameter | Specification |
|--|------------------|
| Temperature | |
| Sustained Storage Limits (i.e., warehouse) | -20 °C to +40 °C |
| Short Duration Limits (i.e., shipping) | -40 °C to +60 °C |

* Processor performance may automatically decrease when the system operates in the top 5 °C of the ambient operating temperature ranges above. This is for local ambient temperature inside the ASUS NUC Rugged NUC13BR Board/Kits chassis.

| | |
|------------------------------|---|
| Intel® Processor N50 (2c/6W) | 0 °C to +40 °C Ambient Operating Temp for Kit and Board SKU |
| Intel Atom® x7211E (2c/6W) | 0 °C to +50 °C Ambient Operating Temp for Kit and Board SKU |
| Intel Atom® x7425E (4c/12W) | 0 °C to +50 °C Ambient Operating Temp for Kit and Board SKU |

| Shock (Board) | | | |
|----------------------|---|---|---|
| Unpackaged | 50 g trapezoidal waveform | | |
| | Velocity change of 170 inches/s ² | | |
| Packaged | Free fall package drop machine set to the height determined by the weight of the package. | | |
| | Product Weight (pounds) | Non-palletized Product drop height (inches) | Palletized drop heights (single product) (inches) |
| | <20 | 36 | N/A |
| | 21-40 | 30 | N/A |
| | 41-80 | 24 | N/A |
| | 81-100 | 18 | 12 |
| 100-120 | 12 | 9 | |

| | |
|---------------------------|--|
| Shock (System) | |
| Unpackaged | 25g trapezoidal waveform |
| | Velocity = 250 inches/sec, 2 shock table drops in each of 6 directions |
| Vibration (Board) | |
| Unpackaged | Random profile 5 Hz @ 0.01 g ² /Hz to 20 Hz @ 0.02 g ² /Hz (slope up) 20 Hz to 500 Hz @ 0.02 g ² /Hz (flat) |
| | Input acceleration is 3.13g RMS |
| Vibration (System) | |
| Unpackaged | Random profile 5 Hz @ 0.001 g ² /Hz to 20 Hz @ 0.01 g ² /Hz (slope up) 20 Hz to 500 Hz @ 0.01 g ² /Hz (flat) |
| | Input acceleration is 2.20g RMS |
| Packaged | Random Profile: 0.001 g ² /Hz to 20 Hz @ 0.01 g ² /Hz (slope up) 20 Hz to 500 Hz @ 0.01 g ² /Hz (flat) |
| | Input acceleration is 2.20g RMS |

Note: The operating temperature of the board may be determined by measuring the air temperature from the junction of the heatsink fins and fan, next to the attachment screw, in a closed chassis, while the system is in operation.

Note: Before attempting to operate this board, the overall temperature of the board must be above the minimum operating temperature specified. It is recommended that the board temperature be at least room temperature before attempting to power on the board. The operating and non-operating environment must avoid condensing humidity.

2.9 Overview of BIOS Features

2.10 Introduction

The board uses an ASUS AMI BIOS core that is stored in the Serial Peripheral Interface Flash Memory (SPI Flash) and can be updated through multiple methods (see Section 4.2). The SPI Flash contains the BIOS Setup program, POST, the PCI auto-configuration utility, LAN EEPROM information, and Plug and Play support. The SPI Flash includes a 32 MB flash memory device.

The BIOS Setup program can be used to view and change the identification information and the BIOS settings for the system. The BIOS Setup program is accessed by pressing <F2> after the POST memory test beings and before the operating system boots.

2.11 BIOS Updates

The BIOS can be updated using one of the following methods:

1. Express BIOS (Windows-based) Update
2. F7 Update
3. Power Button Menu Update
4. UEFI Shell Update

More information and instructions on how to use each of these methods can be found at [BIOS Update and Recovery Instructions](#). All BIOS update files for ASUS NUCs are available on [Download Center](#).

2.12 BIOS Recovery

It is unlikely that anything will interrupt a BIOS update; however, if an interruption occurs the BIOS could be unstable. Table 25 lists the drives and media types that can be used for BIOS recovery. The BIOS recovery media does not need to be made bootable. More information about BIOS recovery methods and instructions can be found at [BIOS Update and Recovery Instructions](#).

Table 24. Acceptable Drives/Media Type for BIOS Recovery

| Media Type ^(Note) | Can be used for BIOS recovery? |
|--|--------------------------------|
| Hard disk drive (connected to SATA or USB) | Yes |
| USB flash drive | Yes |
| NVME SSD (M.2 interface) | Yes |



NOTE Supported file systems for BIOS recovery: NTFS (sparse, compressed, or encrypted files are not supported), FAT32, EXT

2.13 Boot Options

In the BIOS Setup program, the user can choose to boot from a hard drive, removeable driver, or the network. The default setting is for the hard drive to be the first boot device, the removeable drive second, and the network third.



NOTE *The network can be selected as a boot device. This selection allows booting from the onboard LAN or a network add-in card with a remote boot ROM installed. Pressing the <F12> key during POST automatically forces booting from the LAN. To use this key during POST, the User Access Level in the BIOS Setup program's Security menu must be set to Full.*

2.13.1 Boot Device Selection During Post

Pressing the <F10> key during POST causes a boot device menu to be displayed. The menu displays the list of available boot devices.

2.13.2 Power Button Menu

As an alternative to Configuration Mode or normal POST hotkeys, the user can use the power button to access a menu with BIOS and boot options. The Power Button Menu is accessible via the following sequence:

1. System is in S4/S5 (not G3).
2. The user pushes the power button and holds it down for 3 seconds.
3. The Power Button LED will be white color for the first 3 seconds. After 3 seconds, switch the Power Button LED to yellow color to signal the user to release the power button.
4. User releases the power button before the 4-second shutdown override.

If this boot path is taken, the BIOS uses default settings, ignoring settings in VPD where possible. At the point where Setup Entry/Boot would be in the normal boot path, the BIOS displays the following prompt and wait for a keystroke:

If an unrecognized key is hit, then the BIOS does nothing and waits for another keystroke. If one of the listed hotkeys is hit, the BIOS will follow the indicated boot path. Password requirements must still be honored.

Table 25. Power Button Menu Options

| Keystroke | Option | Description |
|-----------|-----------------------|--|
| [ESC] | Normal Boot | |
| [F2] | BIOS Setup Menu | |
| [F3] | Disable Fast Boot | Note: Is only be displayed if at least one Fast Boot optimization is enabled. If Disable Fast Boot is selected, the BIOS disables all Fast Boot optimizations and reset the system. |
| [F4] | BIOS Recovery | The BIOS searches for a matching .CAP file from the \EFI\ASUS folder in the supported media with the supported file system. If a matching recovery capsule is found, the BIOS displays the following: BIOS Recovers to <BIOSID> in 20 seconds. [ESC] Cancel Recovery |
| | | Recovery proceeds if not cancelled via the ESC key within 20 seconds. The BIOS displays the recovery progress. If a BIOS .CAP file was not detected (or the BIOS Recovery was cancelled) then the BIOS resets the system and continues normally to POST. |
| [F5] | Restore BIOS Settings | The BIOS restores the current setup settings and the current defaults to the build time defaults in the case of a boot issue caused by setup variable changes. |

2.14 Hard Disk Drive Password Security Feature

The Hard Disk Drive Password Security feature blocks read and write access to the hard disk drive until the correct password is given. Hard disk drive passwords are set in BIOS Setup and are prompted for BIOS POST. For convenient support for resuming from Modern Standby, the system BIOS automatically unlocks drives on resume from Modern Standby. Valid password characters are A-Z, a-z, and 0-9. Passwords may be up to 32 characters in length.

The User hard disk drive password, when set, is required on each power cycle until the Master Key or User hard disk drive password is submitted.

The Master Key hard disk drive password, when set, will not lock the drive. The Master Key hard disk drive password exists as an unlock override if the User hard disk drive password is forgotten. Only the User hard disk drive password, when set, causes a hard disk to be locked on a system power cycle. show the effects of setting the hard disk drive passwords.

Table 26. Master Key and User Hard Disk Drive Password Functions

| Password Set | Password During Boot |
|---------------------|----------------------|
| Neither | None |
| Master only | None |
| User only | User only |
| Master and User Set | User |

During every POST, if a User hard disk drive password is set, POST execution pauses with the following prompt to force the User to enter the Master Key or the User hard disk drive password:

“Enter Hard Disk Drive Password:”

Upon successful entry of the Master Key or User hard disk drive password, the system proceeds with normal POST.

If the hard disk drive password is not correctly entered, the system goes back to the above prompt. The User has three attempts to correctly enter the hard disk drive password. After the third unsuccessful attempt, the system halts with the following message:

“Hard Disk Drive Password Entry Error”

A manual power cycle is required to resume system operation.



NOTE *As implemented on the ASUS NUC13AN / NUC13LC board, the hard disk drive password security feature is only supported on the SATA Port 0 (M.2) or the SATA port 1 (onboard SATA connector).*

2.15 BIOS Security Features

BIOS includes security features that restrict access to the BIOS Setup program and who can boot the computer. A Supervisor and User password can be set for the BIOS Setup program and for booting the computer, with the following restrictions:

- The Supervisor password gives unrestricted access to view and change all the Setup options in the BIOS Setup program. This is Supervisor Mode.
- The User password gives restricted access to view and change Setup options in the BIOS Setup program. This is User Mode.
- If only the Supervisor password is set, pressing the <Enter> key at the password prompt of the BIOS Setup program allows the user restricted access to Setup.
- If both the Supervisor and User passwords are set, users can enter either the Supervisor or User password to access Setup. Users have access to Setup regardless of which password is used.
- Setting the User password restricts who can boot the computer. The password prompt is displayed before the computer boots. If only the Supervisor password is set, the computer boots without asking for a password. If both passwords are set, the user can enter either password to boot the computer.
- For enhanced security, use different passwords for the Supervisor and User passwords.
- Valid password characters are A-Z, a-z, 0-9, and special characters. Passwords may be up to 20 characters in length.
- To clear a set password, enter a blank password after entering the existing password.

Table 29 shows the effects of setting the Supervisor password and User password. This table is for reference only and is not displayed on the screen.

Table 27. Supervisor and User Password Functions

| Password Set | Supervisor Mode | User Mode | Setup Options | Password to Enter Setup | Password During Boot |
|-------------------------|---------------------------------|--|---------------------------------------|-------------------------|----------------------|
| Neither | Any user can change all options | Any user can change all options | None | None | None |
| Supervisor only | Can change all options | Can change a limited number of options | Supervisor Password | Supervisor | None |
| User only | N/A | Can change all options | Enter Password Clear User Password | User | User |
| Supervisor and User set | Can change all options | Can change a limited number of options | Supervisor Password Enter Password | Supervisor or User | Supervisor or User |

2.16 BIOS Error Messages

Table 29 lists the error messages and provides a brief description of each.

Table 28. BIOS Error Messages

| Error Message | Explanation |
|------------------------|---|
| CMOS Battery Failure | The battery may be losing power. Replace the battery soon. |
| CMOS Checksum Error | The CMOS checksum is incorrect. CMOS memory may have been corrupted. Run Setup to reset values. |
| Memory Size Decreased | Memory size has decreased since the last boot. If no memory was removed, then the memory may be bad. |
| CMOS Timer Not Set | The battery may be losing power. Replace the battery soon. |
| Processor Thermal Trip | Processor overheated. |
| Auto RTC Reset | The system triggers RTC clear to recover the system back to normal condition from consecutive boot failure. |

3 Characterized Errata

This section of the document communicates product Errata for the ASUS NUC 13 Rugged Kit and Board.

Errata are design defects or deviations from current published specifications for a given product. Published errata may or may not be corrected. Hardware and software designed to be used with any given processor stepping must assume that all errata documented for that processor stepping are present on all devices.

There are no characterized errata at this time.