

# ROG Z11

## GAMING CHASSIS



# User Manual

The CES Innovation Awards are based upon descriptive materials submitted to the judges. CTA did not verify the accuracy of any submission or of any claims made and did not test the item to which the award was given.

# GAMERS | Generational Awakening Mechanically Enhanced Revivalors

## SE7EN

One of the Cyber Samurai, is a trained assassin posing undercover as a runway model.

Stepping through the crowd, Se7en turns on her Bullet Time superpower and moves with the speed of a bullet to wipe out her enemies.

She shoots a cybernetic chain-whip from her right hand, making it slither viciously across the throats of adversaries like a snake, and draws the Damascus steel knife hidden on her left wrist to cut through opponents mercilessly.

Coldly glancing at the snow turned vivid red by the blood of her foes, Se7en once again vanishes into the crowd.



**Copyright © 2022 ASUSTeK Computer Inc.  
All Rights Reserved.**

No part of this manual, including the products and software described in it, may be reproduced, transmitted, transcribed, stored in a retrieval system, or translated into any language in any form or by any means, except documentation kept by the purchaser for backup purposes, without the express written permission of ASUSTeK Computer Inc. ("ASUS").

Product warranty or service will not be extended if: (1) the product is repaired, modified or altered, unless such repair, modification or alteration is authorized in writing by ASUS; or (2) the serial number of the product is defaced or missing.

ASUS PROVIDES THIS MANUAL "AS IS" WITHOUT WARRANTY OF ANY KIND, EITHER EXPRESS OR IMPLIED, INCLUDING BUT NOT LIMITED TO THE IMPLIED WARRANTIES OR CONDITIONS OF MERCHANTABILITY OR FITNESS FOR A PARTICULAR PURPOSE. IN NO EVENT SHALL ASUS, ITS DIRECTORS, OFFICERS, EMPLOYEES OR AGENTS BE LIABLE FOR ANY INDIRECT, SPECIAL, INCIDENTAL, OR CONSEQUENTIAL DAMAGES (INCLUDING DAMAGES FOR LOSS OF PROFITS, LOSS OF BUSINESS, LOSS OF USE OR DATA, INTERRUPTION OF BUSINESS AND THE LIKE), EVEN IF ASUS HAS BEEN ADVISED OF THE POSSIBILITY OF SUCH DAMAGES ARISING FROM ANY DEFECT OR ERROR IN THIS MANUAL OR PRODUCT.

SPECIFICATIONS AND INFORMATION CONTAINED IN THIS MANUAL ARE FURNISHED FOR INFORMATIONAL USE ONLY, AND ARE SUBJECT TO CHANGE AT ANY TIME WITHOUT NOTICE, AND SHOULD NOT BE CONSTRUED AS A COMMITMENT BY ASUS. ASUS ASSUMES NO RESPONSIBILITY OR LIABILITY FOR ANY ERRORS OR INACCURACIES THAT MAY APPEAR IN THIS MANUAL, INCLUDING THE PRODUCTS AND SOFTWARE DESCRIBED IN IT.

Products and corporate names appearing in this manual may or may not be registered trademarks or copyrights of their respective companies, and are used only for identification or explanation and to the owners' benefit, without intent to infringe.

# CONTENTS

## ACCESSORY KIT CONTENTS

### INSTALLATION GUIDE

Remove the Side Panels	3
Multifunction Cover	4
Install The Power Supply Unit (PSU)	5
Install the Cooler & RAM on the Motherboard	7
Install the Motherboard Unit	9
Attach the PCI-E Card	10
Sync Case Lighting With Addressable RGB Compatible Motherboards	11
Extension Hub	12
Install the 3.5"/ 2.5" Drives	13
Installation and Maintenance of the Dust Filters	14
Pump Installation	15
GPU Water Block	16













### ADDITIONAL INFORMATION

CPU Cooler Height Limitation	18
Graphics Card Limitation	19
Fan Setup Compatibility	20
Water-cooling Radiator Options	21
Optional Nameplate	22
Chassis Placement	23

### SAFETY INFORMATION

# ACCESSORY KIT CONTENTS

配備零組件內容物 | 配備組件內容物 | Obsah sady příslušenství | Contenu du kit d'accessoires | Verpackungsinhalt des  
 Zubehörsatzes | Accessori contenuti nel kit | アクセサリーキットの内容 | 액세서리 키트 내용물 | Zawartość zestawu  
 akcesoriów | Conteúdo do kit de acessórios | Содержимое комплекта | Contenido del kit de accesorios |  
 Tillbehörssatsens innehåll | Aksesor Kitinin İçindekiler | محتويات طقم الملحقات | תוכן ערכת האביזרים

<b>A</b>		<b>Motherboard / 3.5" Drive / PSU Screws</b>	<b>x14</b>
<b>B</b>		<b>2.5" Drive Screws</b>	<b>x16</b>
<b>C</b>		<b>Graphics Card Screws</b>	<b>x2</b>
<b>D</b>		<b>120mm Radiator Bracket Screws</b>	<b>x4</b>
<b>E</b>		<b>Motherboard Standoff Tool</b>	<b>x1</b>
<b>F</b>		<b>Cable Ties</b>	<b>x10</b>
<b>G</b>		<b>PUMP Bracket</b>	<b>x1</b>
<b>H</b>		<b>SFX PSU Bracket</b>	<b>x1</b>
<b>I</b>		<b>120mm Radiator Bracket</b>	<b>x1</b>
<b>J</b>		<b>90° Angle Adapter</b>	<b>x1</b>
<b>K</b>		<b>Nameplate</b>	<b>x1</b>
<b>L</b>		<b>Front Panel / Side Panel Screws (Backup)</b>	<b>x4</b>
<b>M</b>		<b>Screws Driver</b>	<b>x1</b>

# INSTALLATION GUIDE

安裝指南 | 安裝指南 | Instalační příručka | Guide d'installation | Installationsanleitung | Guida all'installazione | 組み立て  
ガイド | 설치 설명서 | Instrukcja instalacji | Manual de instalação | Руководство по установке | Guía de instalación |  
Installationsguide | Kurulum Kılavuzu | دليل التركيب | מדריך התקנה | دليل التركيب

# REMOVE THE SIDE PANELS

移除側面板 | 移除側面板 | Sejměte boční panely | Retirer les panneaux latéraux | Entfernen der Seitenwände | Rimuovete i pannelli laterali | サイドパネルを取り外す | 측면 패널 제거 | Zdejmij panele boczne | Remover os painéis laterais | Снимите боковые панели | Quite los paneles laterales | Ta bort sidopanelerna | Yan Panelleri Çıkarın | הסר את הפאנלים הצדדיים | أزل الألواح الجانبية

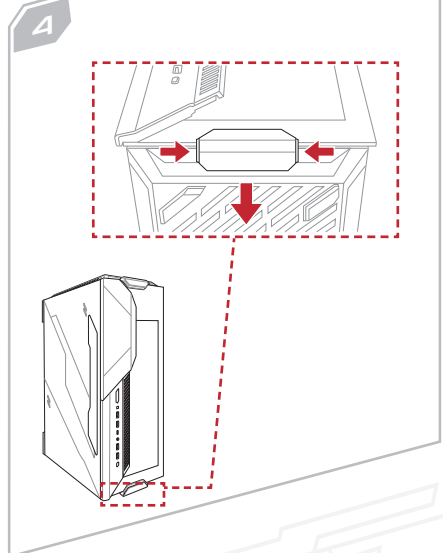
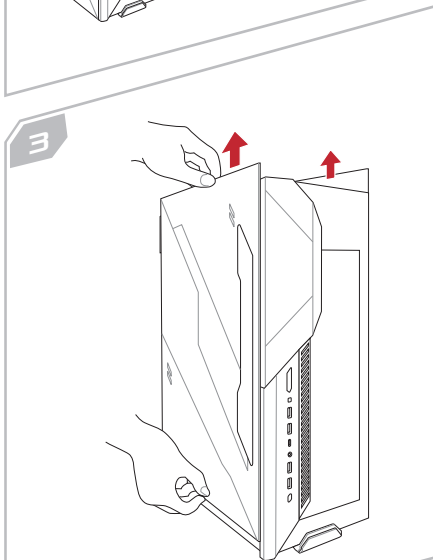
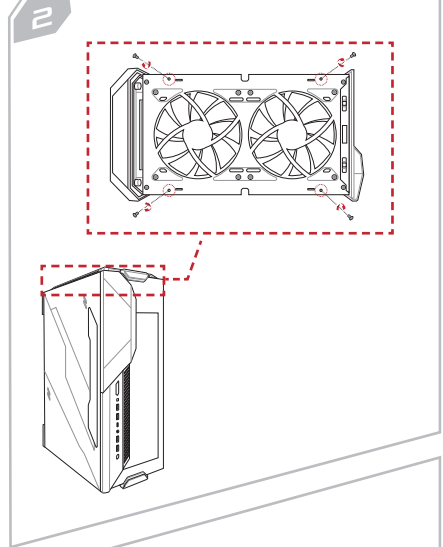
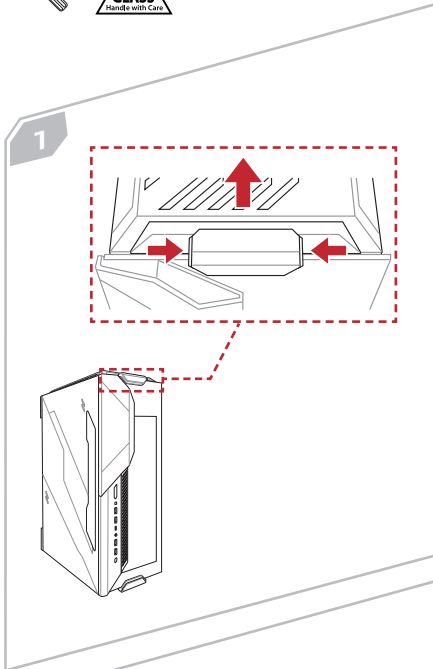

5

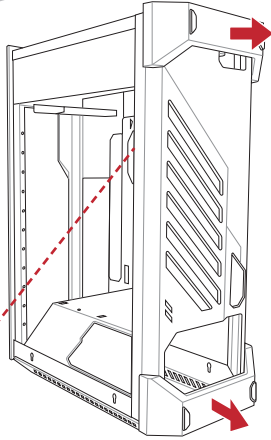
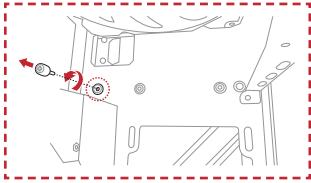



# MULTIFUNCTION COVER

多功能遮蓋板 | 多功能盖板 | Multifunkční kryt | Couverture multifonction | Multifunktionsabdeckung | Cover multifunzione | マルチファンクションカバー | 다기능 커버 | Pokrywa wielofunkcyjna | Tampa multifunções | Многофункциональная крышка | Cubierta multifunción | Multifunktionshölje | Çok İşlevli Kapak | غطاء متعدد الوظائف | מכסה רב שימושי

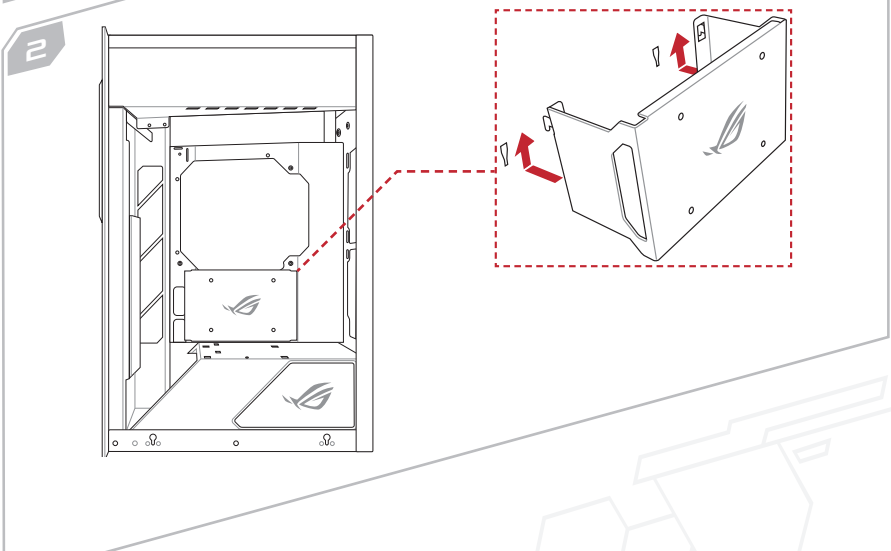
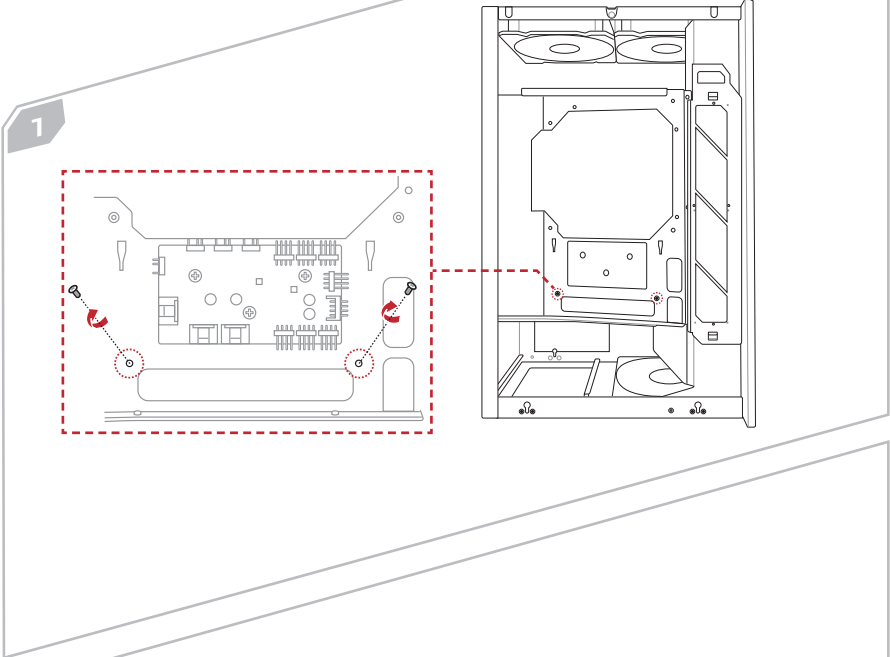

Supports 1 x 2.5" SSD

3

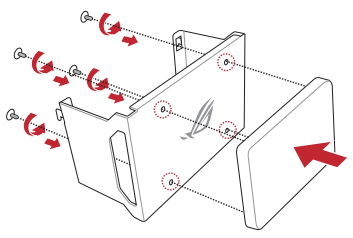

# INSTALL THE POWER SUPPLY UNIT (PSU)

安裝電源供應器 | 安装电源供应器 | Nainstalujte zdroj napájení (PSU) | Installer le bloc d'alimentation | Installation des Netzteils | Installate l'alimentatore (PSU) | 電源装置を取り付ける | 전원 공급장치(PSU) 설치 | Zainstaluj zasilacz (PSU) | Instalar a fonte de alimentação (PSU) | Установите блок питания | Instalar la fuente de alimentación (PSU) | Sätt i strömförsörjningsenheten (PSU) | Güç Kaynağı Ünitesini (PSU) Takın | (PSU) اتركه ووحدة الإمداد بالطاقة | התקן את יחידת ספק החכ |



x4



x1

## ATX PSU:

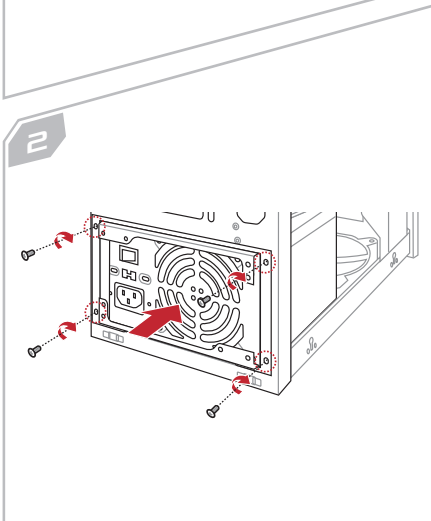
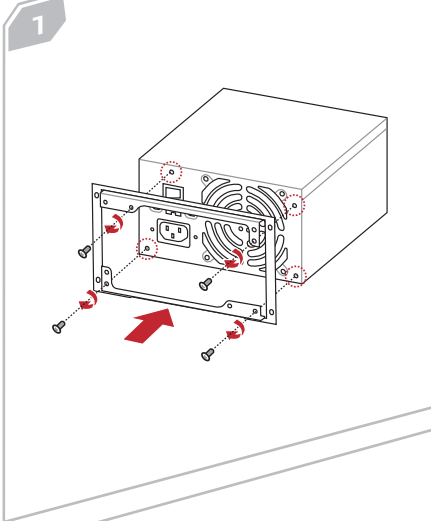

## SFX PSU:

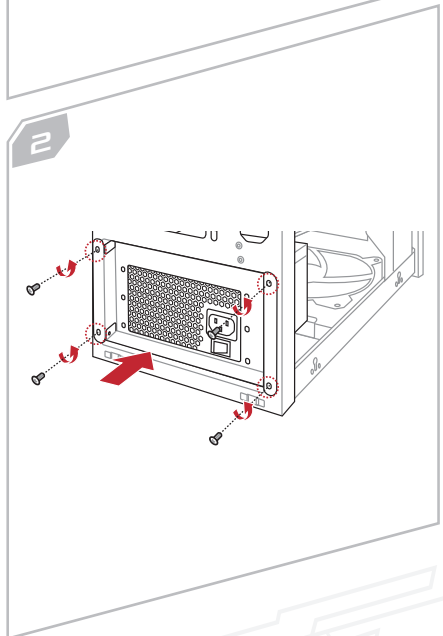
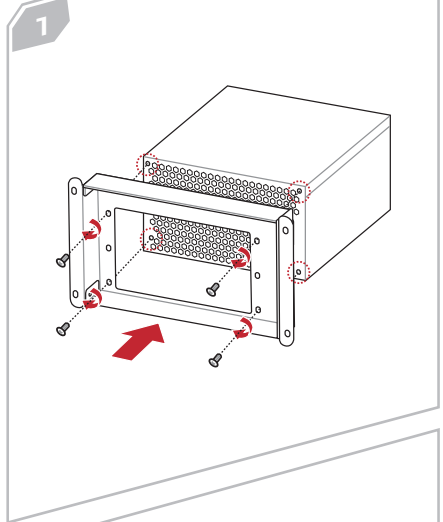

# INSTALL THE COOLER & RAM ON THE MOTHERBOARD

安裝主機板散熱器和記憶體 | 安裝主板散熱器和內存 | Nainstalujte chladič a paměť RAM na základní desku | Installer le refroidisseur et la mémoire RAM sur la carte mère | Installation des Kühlers und der RAM-Module auf das Motherboard | Installate dissipatore e RAM sulla scheda madre | CPU、クーラー、メモリーをマザーボードに取り付ける | 메인보드에 쿨러 및 RAM 설치 | Zainstaluj element chłodzący i pamięć RAM na płycie głównej | Instalar o dissipador e memória RAM na placa principal | Установите на материнскую плату кулер и память | Instalar el refrigerador y la memoria RAM en la placa base | Montera kylare och RAM på moderkortet | Soğutucu ve RAM'i Anakarta Takın |  
باللوحة الأم (RAM) ركيب المبرد وذاكرة الرام |  
תתקן את הקיורור ויחידות הזיכרון RAM על לוח האם

1

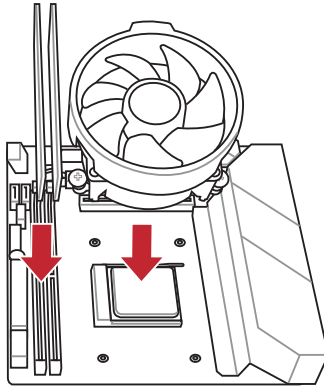

2

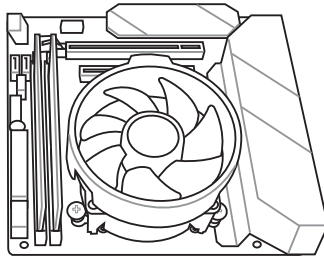

# INSTALL THE MOTHERBOARD UNIT

將主機板裝入機殼 | 將主板裝入机箱 | Nainstalujte základní desku | Installer la carte mère | Installation der Motherboard-Baugruppe | Installate la scheda madre | マザーボードを取り付ける | 메인보드 유닛 설치 | Zainstaluj płytę główną | Instalar a placa principal | Установите материнскую плату | Instalar la unidad de la placa base | Installera moderkortsenheten | Anakart Ünitesini Takın | تركيب وحدة اللوحة الأم | התקן את לוח האם

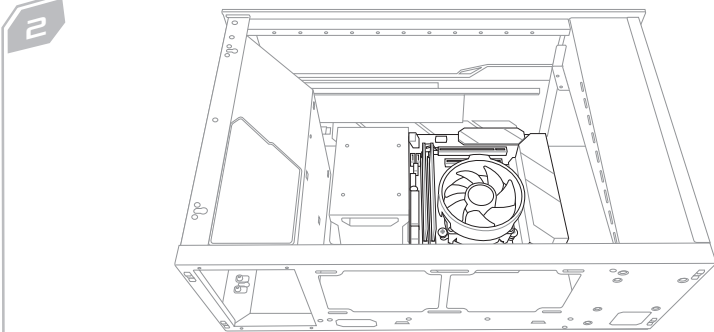
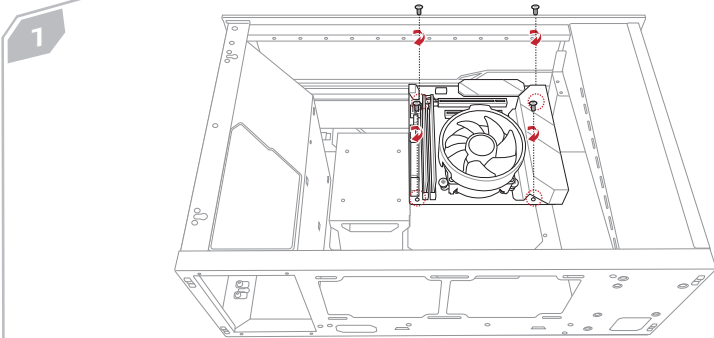
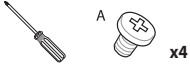

# INSTALL THE PCI-E CARD

安裝 PCI-E 卡 | 安裝 PCI-E 卡 | Nainstalujte PCI-E kartu | Installer la carte PCI-E | Installation der PCI-E-Karte | Installate la scheda PCI-E | 拡張カードを取り付ける | PCI-E 카드 설치 | Zainstaluj kartę PCI-E | Instalar a placa PCI-E | Установите карту PCI-E | Instalar la tarjeta PCI-E | Installera PCI-E-kortet | PCI-E Kartını Takın | تركيب بطاقة PCI-E | התקן את כרטיס ה-PCI-E

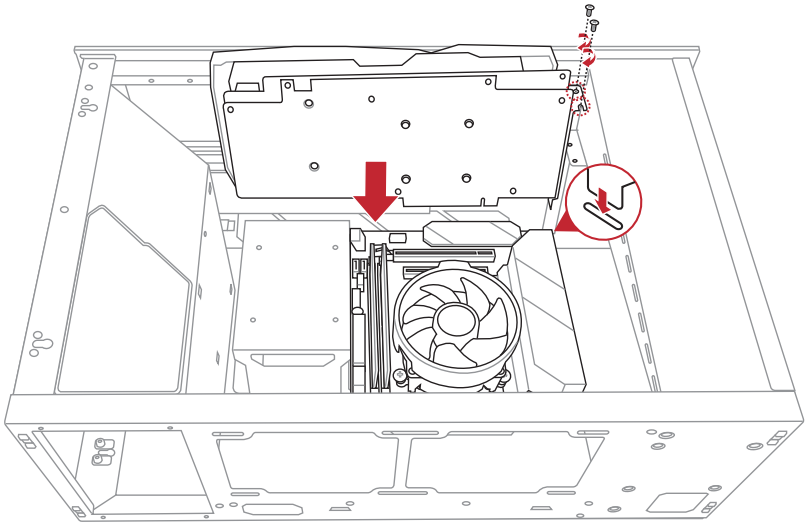





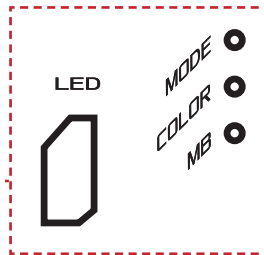

# SYNC CASE LIGHTING WITH ADDRESSABLE RGB COMPATIBLE MOTHERBOARDS

可編程 RGB燈光與可兼容主機板同步燈光控制 | 可編程RGB灯效与可兼容主板同步灯光控制 | Synchronizovat osvětlení skříně se základními deskami, které jsou kompatibilní s adresovatelným RGB | Synchroniser l'éclairage du châssis avec les cartes mères compatibles RGB adressables | Synchronisieren der Gehäusebeleuchtung über ansteuerbare RGB-kompatible Motherboards | Sincronizza l'illuminazione del case con le schede madri compatibili con l'indirizzamento RGB | アドレス対応LED対応マザーボードによるライティングの同期 | 주소 지정이 가능한 RGB를 채택한 싱크 케이스 조명 호환 메인보드 | Synchronizacja podświetlenia obudowy z płytami głównymi zgodnymi z adresowalnym podświetleniem RGB | Sincronizar a iluminação da caixa com placas principais compatíveis com RGB endereçável | Синхронизировать подсветку корпуса с адресуемой RGB-лентой материнской платы | Sincronizar la iluminación de la carcasa con placas base compatibles con RGB direccionable | Hölje med synkroniserat ljus med adresserbara RGB-kompatibla moderkort | Kasa Aydınlatmasını Adreslenebilir RGB Uyumlu Ana Kartlarla Eşitleyin |  
 مزامنة إضاءة الخوالة مع اللوحات الأم المتوافقة مع  
 RGB | סנכרון את תאורת המארז והאלבאלמה ללסוג RGB  
 המשתנה עם לוחות אם מתאימים

Front I/O panel



- Turn on Press LED button for 6 seconds
- Turn off Press LED button for 6 seconds
- Mode Change Press LED button for 2 seconds
- Back to Default Press LED button for 4 seconds
- MB Sync up with MB Lighting
- Mode 
 Static
  Breathing
  Strobing
  Rainbow
- Color 
 White / Red / Orange / Yellow / Green / Blue / Cyan / Purple / Rainbow
- Default 
 Mode: Rainbow Color: Rainbow

\* MB mode only works when connecting control board to MB Addressable RGB header  
 \* Compatible with AURA Sync





# INSTALL THE 3.5" / 2.5" DRIVES

安裝 3.5 / 2.5 吋硬碟 | 安裝 3.5 / 2.5 英寸硬碟 | Nainstalujte 3,5"/2,5" jednotky | Installer les lecteurs 3.5"/2.5" | Installation der 3,5-Zoll-/2,5-Zoll-Laufwerke | Installate i drive 3.5"/2.5" | 3.5インチ/2.5インチドライブを取り付ける | 3.5"/2.5" 드라이브 설치 | Zainstaluj napędy 3,5"/2,5" | Instalar as unidades de 3,5"/2,5" | Установите 3,5/2,5-дюймовые диски | Instalar las unidades de 3,5"/2,5" | Installera 3,5"/2,5"-enheterna | 3,5"/2,5" Sürücüləri Takın | رك القراص الصلب مقاس 2.5/3.5 بوصة | התקן את כונן ה-3.5"/2.5"

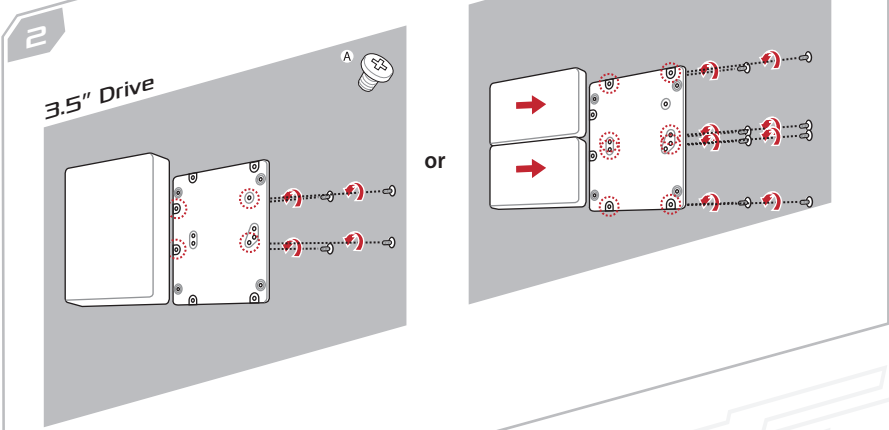
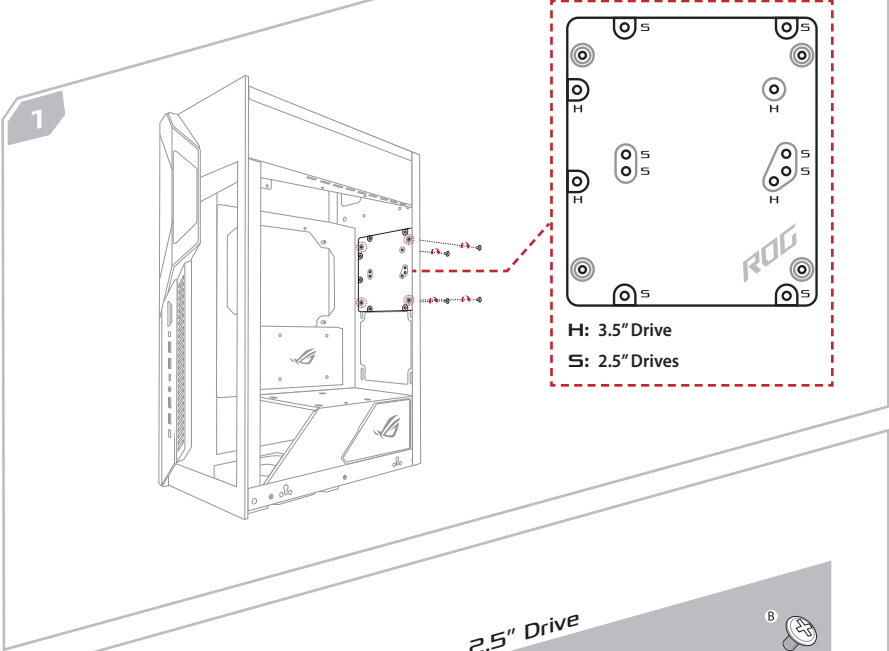

3

2.5" Drive

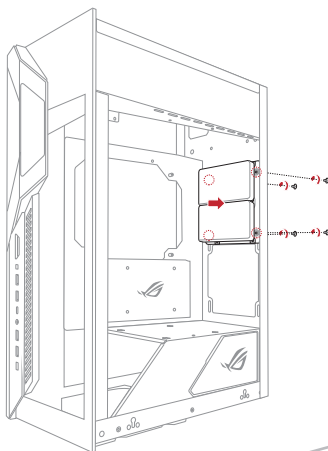

4

2.5" Drive

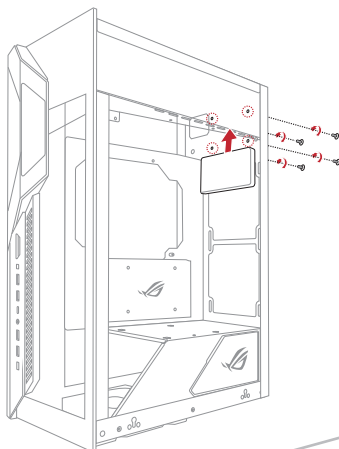

# INSTALLATION AND MAINTENANCE OF THE DUST FILTERS

防塵網安裝及保養 | 防尘网安装及保养 | Instalace a údržba prachových filtrů | Installation et entretien des filtres à poussière | Installation und Wartung der Staubfilter | Installazione e manutenzione dei filtri antipolvere | ダストフィルターを取り付ける | 먼지 필터의 설치 및 유지보수 | Instalacja i konserwacja filtrów antykurzowych | Instalação e manutenção dos filtros de pó | Установка и обслуживание пылевых фильтров | Instalación y mantenimiento de los filtros de polvo | Installation och underhåll av dammfiltern | Toz Filtrelerinin Kurulumu ve Bakımı | تركيب وصيانة فلاتر الغبار | התקנה ותחזוק של פילטרי אבק

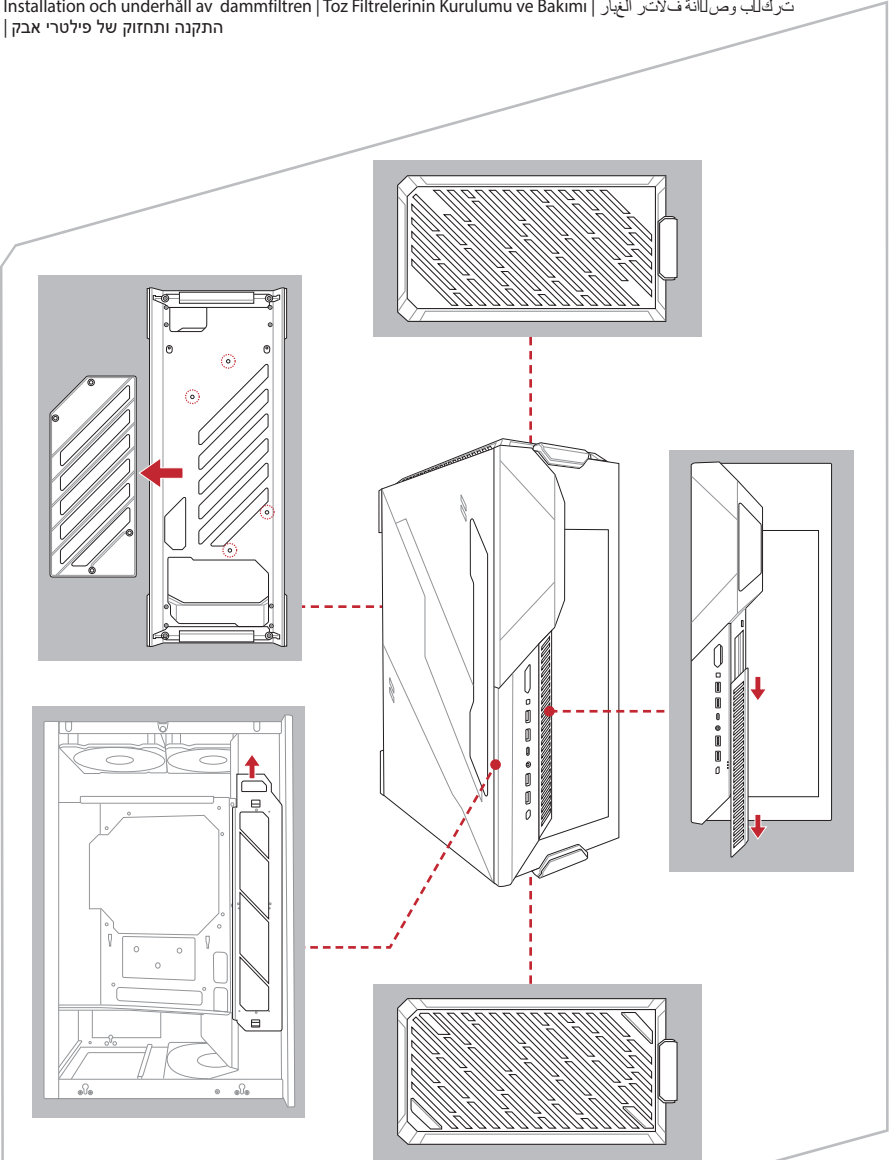

# PUMP INSTALLATION

幫浦安裝 | 水泵安裝 | Instalace čerpadla | Installation de la pompe | Installation der Pumpe | Installazione della pompa | 水冷ポンプの取り付け | 펌프 설치 | Instalacja pompy | Instalação da bomba | Установка помпы | Instalación de la bomba  
| Pumpinstallation | Pompa Kurulumu | تركيب المضخة | התקנת משאבה

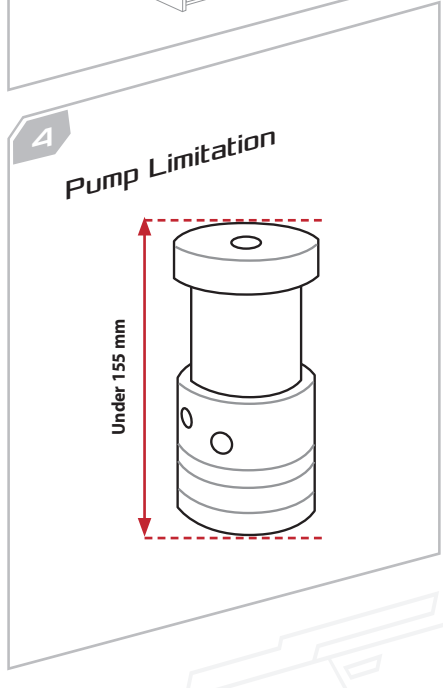
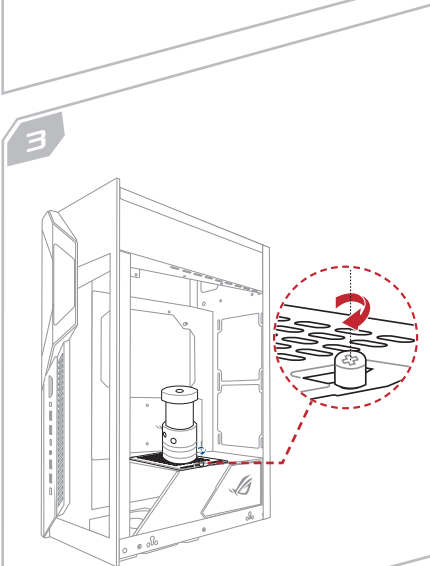
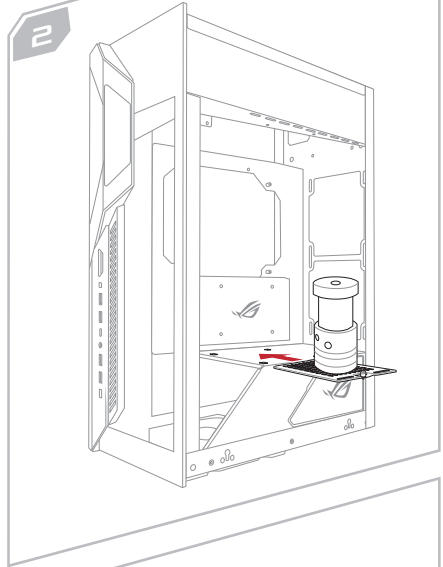
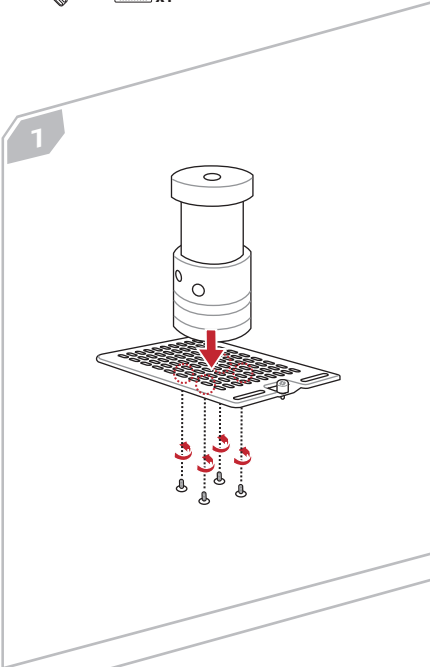

# GPU WATER BLOCK

顯示卡水冷頭 | 显卡水冷头 | Vodní blok pro GPU | Waterblock pour carte graphique | GPU-Wasserkühlung | Monoblocco ad acqua per GPU | GPUウォーターブロック | GPU 워터 블록 | Blok wodny procesora graficznego | Sistema de refrigeração líquido da GPU | Жидкостная система охлаждения для видеокарты | Bloque de agua de la GPU | GPU vattenblock | GPU Su Bloğu | גוף קירור נוזלי לנרטיס מסך | حاجز مياه وحدة معالجة الرسومات

## GPU Water Block Limitation

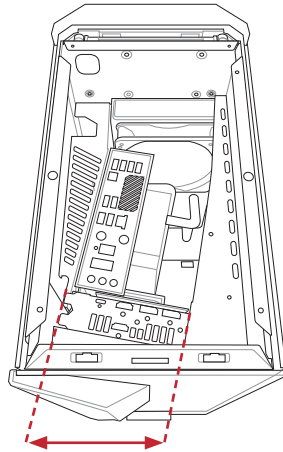

**Length under 155 mm  
(have to use the 90° angle adapter)**

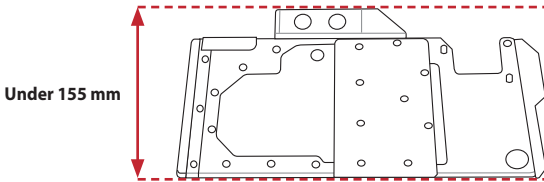

**Under 155 mm**

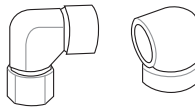

**90° angle adapter**

# ADDITIONAL INFORMATION



附加資訊 | 附加信息 | Dodatečné informace | Informations supplémentaires | Zusätzliche Informationen | Informazioni  
addizionali | 追加情報 | 추가 정보 | Informacje dodatkowe | Informações adicionais | Дополнительная информация |  
Información adicional | Ytterligere information | Ek Bilgiler | معلومات إضافية | מידע נוסף

# CPU COOLER HEIGHT LIMITATION

CPU 散热器高度限制 | CPU 散热器高度限制 | Výškové omezení chladiče CPU | Limitation de hauteur du refroidisseur pour processeur | Höhenbegrenzung des CPU-Kühlers | Limitazioni di altezza per il dissipatore CPU | CPUクーラーの制限 | CPU 쿨러 높이 제한 | Ograniczenie wysokości elementu chłodzącego CPU | Limitação de altura do dissipador da CPU | Ограничения для высоты процессорного кулера | Limitación de la altura del refrigerador de la CPU | Höjdbegränsning av CPU-kylare | CPU Soğutucu Yükseklik Sınırlaması | حد ارتفاع جبرود وحدة المعالجة المركزية | מגבלת גובה לקירור עובר מעבד

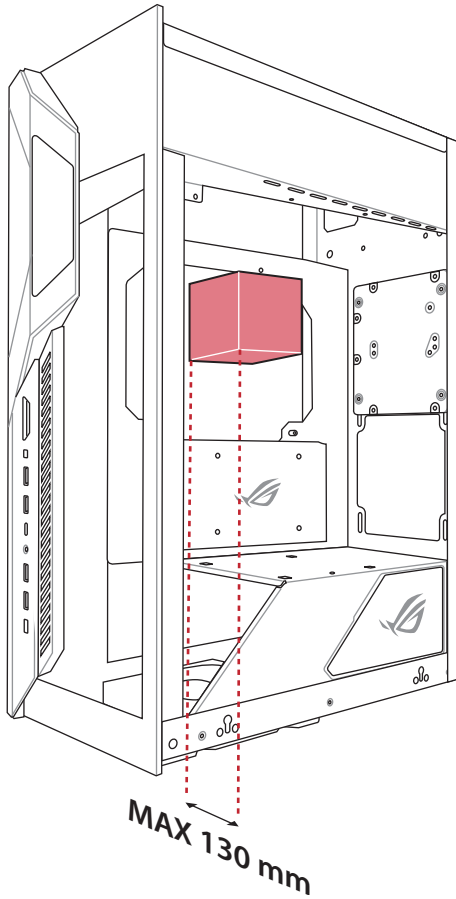



# GRAPHICS CARD LIMITATION

顯示卡長度限制 | 显卡长度限制 | Omezení grafické karty | Limitations de la carte graphique | Beschränkungen der Grafikkarte | Limitazioni per la scheda grafica | グラフィックスカードの制限 | 그래픽 카드 제한 | Ograniczenia karty graficznej | Limitações de placas gráficas | Ограничения для видеокарты | Limitaciones de la tarjeta gráfica | Begränsningar för grafikort | Grafik Kartı Sınırlamaları | حدود بطاقة الرسومات | מגבלת כרטיס מסך

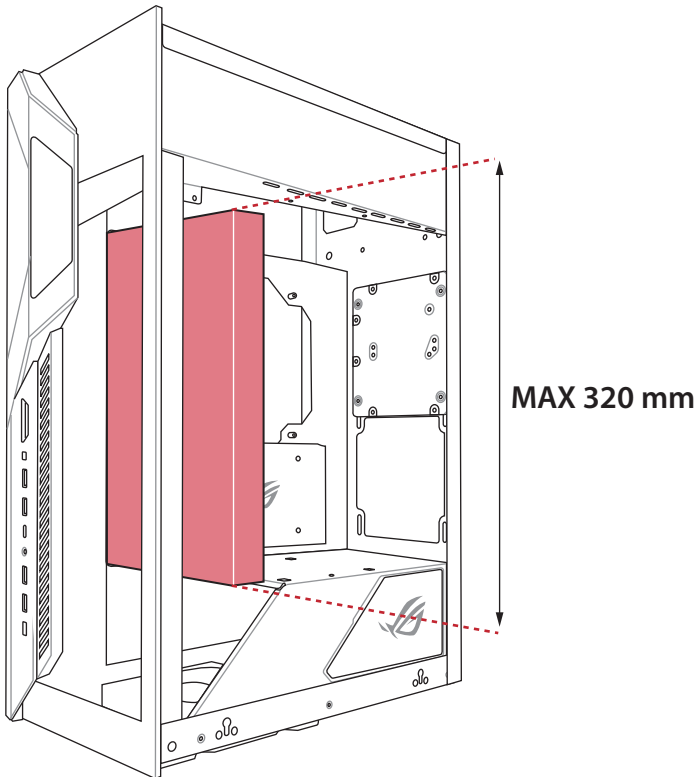

# FAN SETUP COMPATIBILITY

風扇設定相容性 | 風扇設置兼容性 | Kompatibilita nastavení ventilátoru | Compatibilité de configuration du ventilateur | Kompatibilität der Lüftereinrichtung | Specifiche di installazione per le ventole | ファンの取り付け例 | 팬 설치 호환성 | Zgodność instalacji wentylatora | Compatibilidade de ventiladores | Совместимость устанавливаемого вентилятора | Compatibilidad de la configuración del ventilador | Kompatibilitet för fläktinstallation | Fan Kurulumu Uyumluluğu | מערכי מאווררים אפשריים | توافق إعداد البرودة

140 mm



120 mm

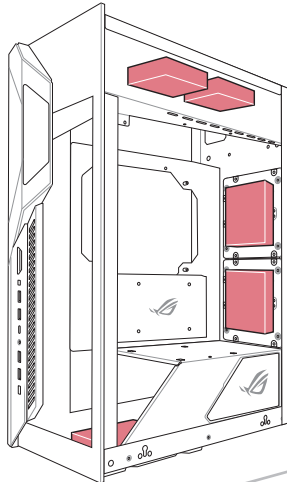

# WATER-COOLING RADIATOR OPTIONS

水冷散熱系統選項 | 水冷散熱系統選項 | Možnosti chladiče vodního chlazení | Options de radiateur à refroidissement par eau | Optionen der Wasserkühlung | Opzioni per radiatore raffreddamento a liquido | 水冷ラジエーターの制限 | 수냉식 라디에이터 옵션 | Opcje instalacji radiatora chłodzonego wodą | Opções de radiadores de refrigeração a água | Варианты радиатора для водяного охлаждения | Opciones del radiador de refrigeración por agua | Alternativ för vattenkylningselement | Su Soğutma Radyatörü Seçenekleri | خيارات مشع تبريد المياه | אפשרויות התקנה לרדיאטורים

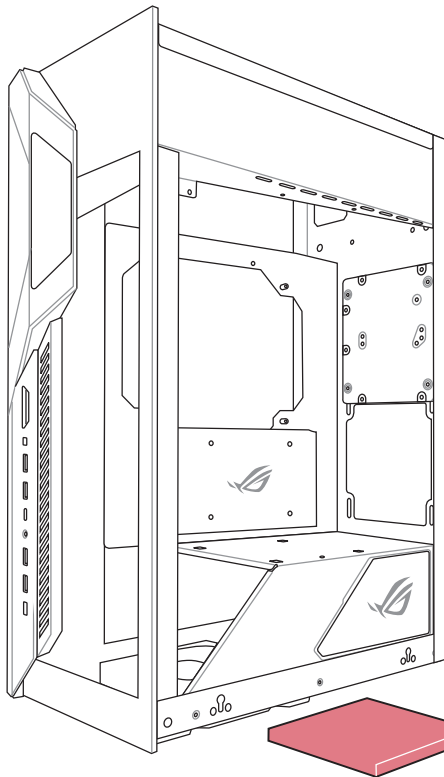

240 mm 120 mm

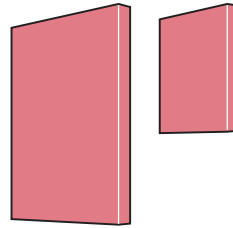

(Thickness: 30 mm)

120 mm

# Install 120mm radiator on the bottom

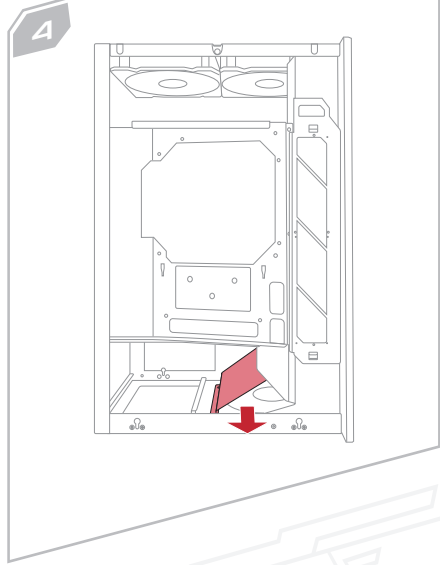
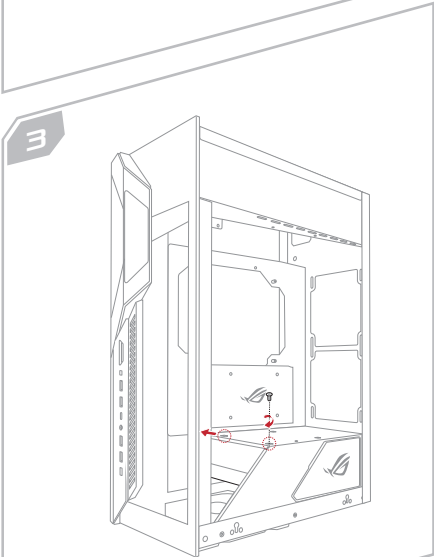
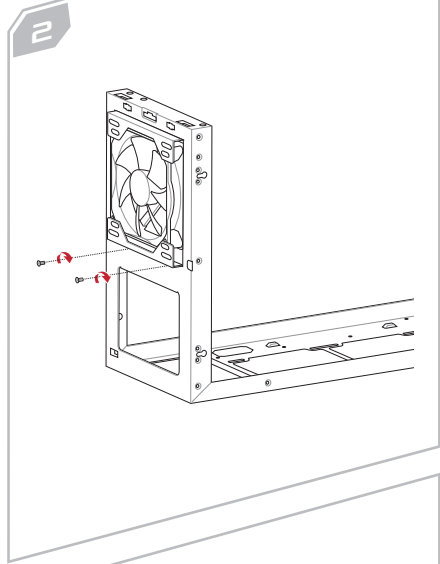
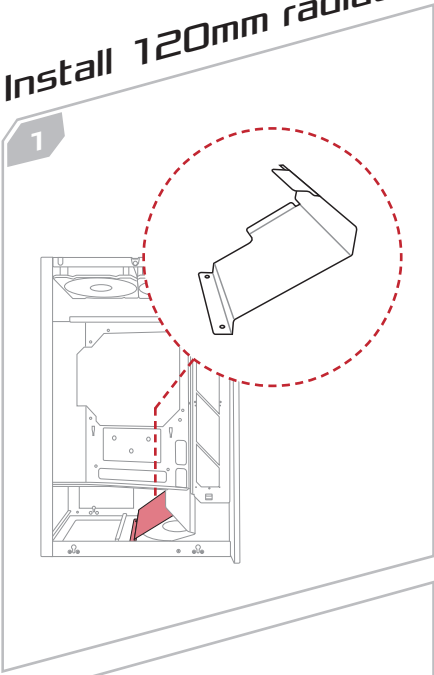

5

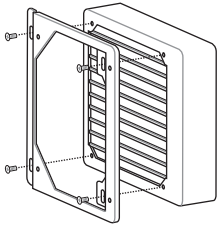

6

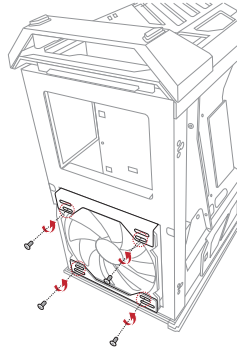

7

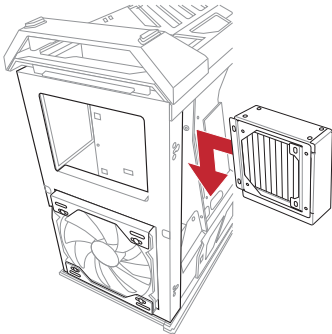

8

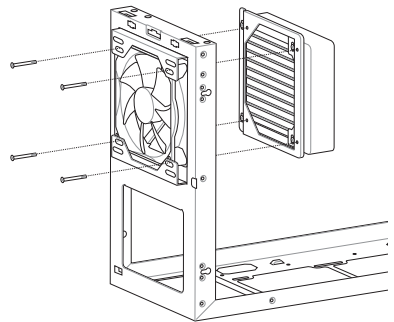

# OPTIONAL NAMEPLATE

選配銘板 | 灯板替换件 | Volitelný výrobní štítek | Plaque d'illumination optionnelle | Optionales Typenschild | Targhetta opzionale | 交換用プレート | 명판(옵션) | Opcjonalna tabliczka | Placa de identificação opcional | Дополнительная табличка | Placa de especificaciones opcional | Namnskyt som tillval | Isteğe Bağlı İsim Plakası | لوحة اسم اختياري | תג שם אופציונלי

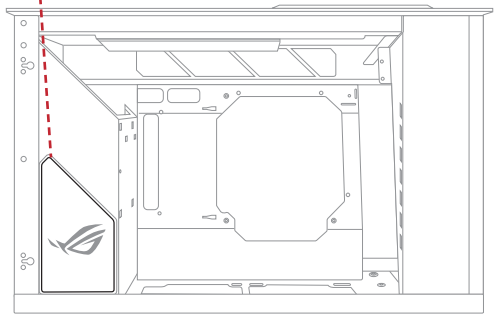
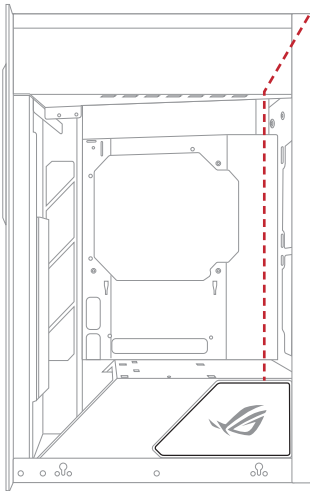
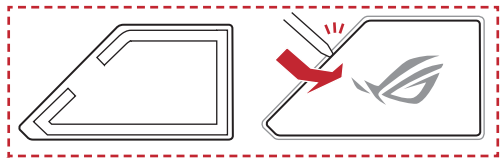

# CHASSIS PLACEMENT

機箱擺放 | 机箱摆放 | Umístění skříně | Positionnement du châssis | Gehäuseaufstellung | Posizionamento dello chassis | ケース配置 | 새시 배치 | Położenie obudowy | Colocação do chassis | Размещение корпуса | Colocación del chasis | Chassiplacement | Kasa Yerleşimi | وضع الكاسه | מיקום מארז מחשב

**Attention:** The stands are for displaying your build only. Please do not use them as handles to lift or carry the case.

## Vertical Position

(O)

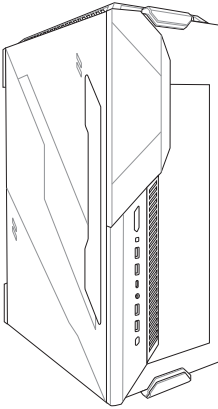

(X)

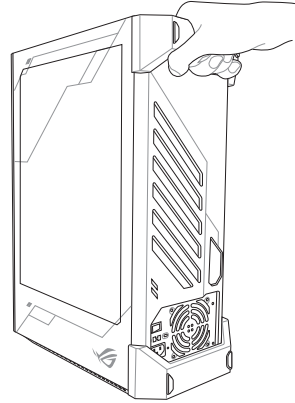

## Horizontal Position

(O)

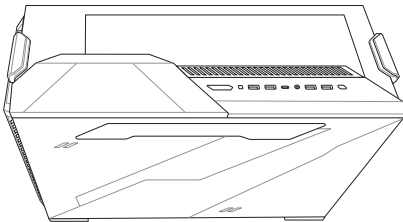

(X)

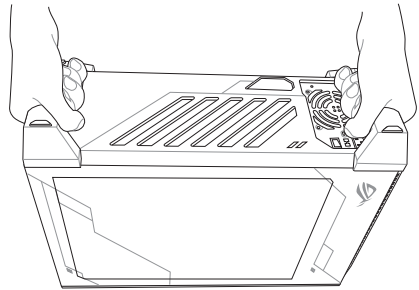



# 90° Angle adapter for displaying chassis in horizontal position

1

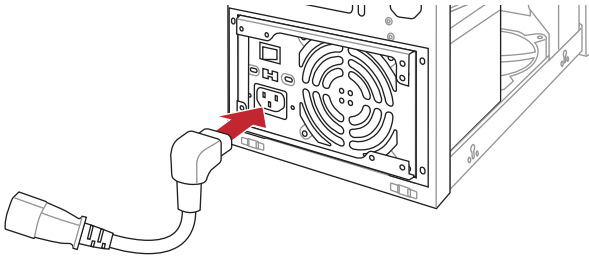

2

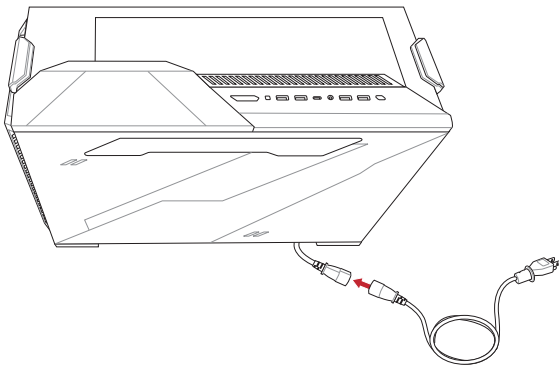



# SAFETY INFORMATION



安規資訊 | 安規信息 | Bezpečnostní informace | Informations relatives à la sécurité | Sicherheitsinformationen |  
Informazioni sulla sicurezza | 製品の安全性に関する情報 | 안전 정보 | Informacje dotyczące bezpieczeństwa |  
Informações de segurança | Информация о правилах безопасности | Información de seguridad | Säkerhetsinformation |  
Güvenlik Bilgileri | معلومات السلامة | מידע בטיחותי | مع لومات السلامة

## Safety Precautions

Accessories that came with this product have been designed and verified for the use in connection with this product. Never use accessories for other products to prevent the risk of electric shock or fire.

## 安全上のご注意

付属品は当該専用品です。他の機器には使用しないでください。機器の破損もしくは、火災や感電の原因となることがあります。

## ASUS Recycling/Takeback Services

ASUS recycling and takeback programs come from our commitment to the highest standards for protecting our environment. We believe in providing solutions for you to be able to responsibly recycle our products, batteries, other components, as well as the packaging materials. Please go to <http://csr.asus.com/english/Takeback.htm> for the detailed recycling information in different regions.

## Australia statement notice

From 1 January 2012 updated warranties apply to all ASUS products, consistent with the Australian Consumer Law. For the latest product warranty details please visit <https://www.asus.com/support/>. Our goods come with guarantees that cannot be excluded under the Australian Consumer Law. You are entitled to a replacement or refund for a major failure and compensation for any other reasonably foreseeable loss or damage. You are also entitled to have the goods repaired or replaced if the goods fail to be of acceptable quality and the failure does not amount to a major failure. If you require assistance please call ASUS Customer Service 1300 2787 88 or visit us at <https://www.asus.com/support/>.

## India RoHS

This product complies with the "India E-Waste (Management) Rules, 2016" and prohibits use of lead, mercury, hexavalent chromium, polybrominated biphenyls (PBBs) and polybrominated diphenyl ethers (PBDEs) in concentrations exceeding 0.1% by weight in homogenous materials and 0.01% by weight in homogenous materials for cadmium, except for the exemptions listed in Schedule II of the Rule.

## REACH

Complying with the REACH (Registration, Evaluation, Authorisation, and Restriction of Chemicals) regulatory framework, we published the chemical substances in our products at ASUS REACH website at <http://csr.asus.com/english/REACH.htm>. (English)

謹遵守REACH(Registration, Evaluation, Authorisation, and Restriction of Chemicals)管理規範・我們會將產品中的化學物質公告在華碩REACH網站・詳細請參考<http://csr.asus.com/english/REACH.htm>。(繁體中文)

謹遵守REACH(Registration, Evaluation, Authorisation, and Restriction of Chemicals)管理規範・我们会將產品中的化學物質公告在華碩REACH網站・詳細請參考<http://csr.asus.com/english/REACH.htm>。(簡體中文)

V rámci shody s regulaturní platformou REACH (Registration, Evaluation, Authorisation, and Restriction of Chemicals (registre, hodnocení, povolování a omezování chemických látek)) byl zveřejněn seznam chemických látek přítomných v našich produktech na webu ASUS REACH na adrese <http://csr.asus.com/english/REACH.htm>. (Čeština)

Conforme avec le Règlement REACH (Enregistrement, Évaluation, Autorisation et Restriction des produits chimiques), nous avons publié la liste des substances chimiques utilisées dans nos produits sur le site Web ASUS REACH à l'adresse <http://csr.asus.com/english/REACH.htm>. (Français)

Die rechtliche Rahmenbedingungen für REACH (Registration, Evaluation, Authorisation, and Restriction of Chemicals) erfüllend, veröffentlichen wir die chemischen Substanzen in unseren Produkten auf unserer ASUS REACH-Webseite unter <http://csr.asus.com/english/REACH.htm>. (Deutsch)

Nel rispetto del regolamento REACH (Registration, Evaluation, Authorisation, and Restriction of Chemicals), le sostanze chimiche contenute nei prodotti ASUS sono state pubblicate nel sito web ASUS, alla pagina: <http://csr.asus.com/english/REACH.htm>. (Italiano)

REACH (Registration, Evaluation, Authorisation, and Restriction of Chemicals)規則の基準を満たすため、ASUSはREACH専用サイトで弊社製品に含まれる化学物質を公開しております。 <http://csr.asus.com/english/REACH.htm>。(日本語)

REACH (Registration, Evaluation, Authorisation, and Restriction of Chemicals) 등록, 평가, 승인 및 화학물질규제) 규제 기준을 준수하여 ASUS REACH 웹사이트 <http://csr.asus.com/english/REACH.htm> 에 당사 제품에 사용된 화학 물질을 게시했습니다. (한국어)

Zgodnie z rozporządzeniem REACH (Rejestracja, ocena, autoryzacja i ograniczenie środków chemicznych), publikujemy informację o środkach chemicznych w naszych produktach, na stronie internetowej ASUS REACH pod adresem <http://csr.asus.com/english/REACH.htm> (Polski)

Cumprindo o quadro regulamentar REACH (Registo, Avaliação, Autorização e Restrição dos Produtos Químicos), divulgamos as substâncias químicas incluídas nos nossos produtos no Web site ASUS REACH em <http://csr.asus.com/english/REACH.htm>. (Português)

Согласно регламенту ЕС REACH (Registration, Evaluation, Authorization, and Restriction of Chemicals – Регистрация, Оценка, Разрешения и Ограничения на использование Химических веществ), на сайте ASUS REACH размещен список химических веществ содержащихся в наших продуктах: <http://csr.asus.com/english/REACH.htm>. (Русский)

En cumplimiento del marco reglamentario REACH (registro, evaluación, autorización y restricción de productos químicos), hemos publicado las sustancias que contienen nuestros productos a través del sitio web ASUS REACH, al que puede acceder a través de la dirección <http://csr.asus.com/english/REACH.htm>. (Español)

Uppfyller REACH (Registration, Evaluation, Authorization, and Restriction of Chemicals (Registrering, Värdering, Behörighet och Begränsning)) reglerande regelverk, vi publicerar de kemiska substanserna i våra produkter på ASUS REACH webbsida på <http://csr.asus.com/english/REACH.htm>. (Svenska)

REACH (Kimyasalların Kayıt Altına Alınması, Değerlendirilmesi, Ruhsatlandırılması ve Sınırlandırılması) düzenleyici çerçevesine uygun olarak, ürünlerimizdeki kimyasal maddeleri <http://csr.asus.com/english/REACH.htm> adresindeki ASUS REACH websitesinde yayınlamaktayız. (Türkçe)

امثالاً لإطار العمل التنظيمي الخاص بتسجيل المواد الكيميائية وتقييمها والتصديق عليها وتقييد استخدامها (REACH)، قمنا بنشر المواد الكيميائية المستخدمة في منتجاتنا على موقع ASUS REACH على العنوان <http://csr.asus.com/english/REACH.htm>. (عربي)



电子电气产品有害物质限制使用标识：图中之数字为产品之环保使用期限。仅指电子电气产品中含有的有害物质不致发生外泄或突变，从而对环境造成污染或对人身、财产造成严重损害的期限。

有害物质名称及含量说明标示：

部件名称	有害物质					
	铅 (Pb)	汞 (Hg)	镉 (Cd)	六价铬 (Cr <sup>6+</sup> )	多溴联苯 (PBB)	多溴二苯醚 (PBDE)
机箱组	○	○	○	○	○	○
面板右组	○	○	○	○	○	○
面板左组	○	○	○	○	○	○
I/O模组	×	○	○	○	○	○
风扇	○	○	○	○	○	○
零件包	×	○	○	○	○	○

本表格依据 SJ/T 11364 的规定编制。

○：表示该有害物质在该部件所有均质材料中的含量均在 GB/T 26572 规定的限量要求以下。

×：表示该有害物质至少在该部件的某一均质材料中的含量超出 GB/T 26572 规定的限量要求，然该部件仍符合欧盟指令 2011/65/EU 的规范。

备注：此产品所标示之环保使用期限，系指在一般正常使用状况下。

## Türkiye AEEE Yönetmeliğine Uygundur.

## France sorting and recycling information

FR  
Cet appareil et ses accessoires se recyclent

REPRISE À LA LIVRAISON  
OU

À DÉPOSER EN MAGASIN  
OU

À DÉPOSER EN DÉCHÈTERIE

Points de collecte sur [www.quefairedemesdechets.fr](http://www.quefairedemesdechets.fr)  
Privilégiez la réparation ou le don de votre appareil !







# GAMERS

G.A.M.E.R.s, a subspecies of humans with superpowers, are activated by the element silicon and appear suddenly, dividing the human world and descending it into conflict and chaos.

During the final days of this apocalypse, seven Cyber Samurai gather at the crossroads of fate and prepare to lead G.A.M.E.R.s to the promised land – THE REPUBLIC OF GAMERS.

A new future awaits.



