



IMX8P-IM-A R2.0

User Manual



E20977

First Edition

September 2022

COPYRIGHT INFORMATION

No part of this manual, including the products and software described in it, may be reproduced, transmitted, transcribed, stored in a retrieval system, or translated into any language in any form or by any means, except documentation kept by the purchaser for backup purposes, without the express written permission of ASUSTeK COMPUTER INC. ("ASUS").

ASUS PROVIDES THIS MANUAL "AS IS" WITHOUT WARRANTY OF ANY KIND, EITHER EXPRESS OR IMPLIED, INCLUDING BUT NOT LIMITED TO THE IMPLIED WARRANTIES OR CONDITIONS OF MERCHANTABILITY OR FITNESS FOR A PARTICULAR PURPOSE. IN NO EVENT SHALL ASUS, ITS DIRECTORS, OFFICERS, EMPLOYEES OR AGENTS BE LIABLE FOR ANY INDIRECT, SPECIAL, INCIDENTAL, OR CONSEQUENTIAL DAMAGES (INCLUDING DAMAGES FOR LOSS OF PROFITS, LOSS OF BUSINESS, LOSS OF USE OR DATA, INTERRUPTION OF BUSINESS AND THE LIKE), EVEN IF ASUS HAS BEEN ADVISED OF THE POSSIBILITY OF SUCH DAMAGES ARISING FROM ANY DEFECT OR ERROR IN THIS MANUAL OR PRODUCT.

Products and corporate names appearing in this manual may or may not be registered trademarks or copyrights of their respective companies, and are used only for identification or explanation and to the owners' benefit, without intent to infringe.

SPECIFICATIONS AND INFORMATION CONTAINED IN THIS MANUAL ARE FURNISHED FOR INFORMATIONAL USE ONLY, AND ARE SUBJECT TO CHANGE AT ANY TIME WITHOUT NOTICE, AND SHOULD NOT BE CONSTRUED AS A COMMITMENT BY ASUS. ASUS ASSUMES NO RESPONSIBILITY OR LIABILITY FOR ANY ERRORS OR INACCURACIES THAT MAY APPEAR IN THIS MANUAL, INCLUDING THE PRODUCTS AND SOFTWARE DESCRIBED IN IT.

Copyright © 2022 ASUSTeK COMPUTER INC. All Rights Reserved.

LIMITATION OF LIABILITY

Circumstances may arise where because of a default on ASUS' part or other liability, you are entitled to recover damages from ASUS. In each such instance, regardless of the basis on which you are entitled to claim damages from ASUS, ASUS is liable for no more than damages for bodily injury (including death) and damage to real property and tangible personal property; or any other actual and direct damages resulted from omission or failure of performing legal duties under this Warranty Statement, up to the listed contract price of each product.

ASUS will only be responsible for or indemnify you for loss, damages or claims based in contract, tort or infringement under this Warranty Statement.

This limit also applies to ASUS' suppliers and its reseller. It is the maximum for which ASUS, its suppliers, and your reseller are collectively responsible.

UNDER NO CIRCUMSTANCES IS ASUS LIABLE FOR ANY OF THE FOLLOWING: (1) THIRD-PARTY CLAIMS AGAINST YOU FOR DAMAGES; (2) LOSS OF, OR DAMAGE TO, YOUR RECORDS OR DATA; OR (3) SPECIAL, INCIDENTAL, OR INDIRECT DAMAGES OR FOR ANY ECONOMIC CONSEQUENTIAL DAMAGES (INCLUDING LOST PROFITS OR SAVINGS), EVEN IF ASUS, ITS SUPPLIERS OR YOUR RESELLER IS INFORMED OF THEIR POSSIBILITY.

SERVICE AND SUPPORT

Visit our multi-language web site at <https://www.asus.com/support/>

Contents

About this manual.....	4
Conventions used in this manual.....	5
Package contents	6

Chapter 1: Specifications Summary

IMX8P-IM-A R2.0 Specifications Summary	8
--	---

Chapter 2: Product Introduction

2.1 Before you proceed	12
2.2 Motherboard layout.....	13
2.3 Onboard button and switches	15
2.4 Internal connectors	17
2.5 I/O connectors.....	26

Chapter 3: Upgrading your Single Board Computer

3.1 Installing an Micro SD card	30
3.2 Installing the wireless card	31

Appendix

Safety information.....	34
Setting up your system.....	34
Care during use.....	35
Regulatory notices	36
Service and Support	42

About this manual

This manual provides information about the hardware and software features of your Single Board Computer, organized through the following chapters:

Chapter 1: Specifications Summary

This chapter details the hardware and software features of your Single Board Computer.

Chapter 2: Product Introduction

This chapter describes the features of the motherboard. It includes description of the connectors, and I/O ports on the motherboard.

Chapter 3: Upgrading your Single Board Computer

This chapter provides you with information on how to upgrade your Single Board Computer.

Appendix

This section includes notices and safety statements your Single Board Computer.

Conventions used in this manual

To highlight key information in this manual, some text are presented as follows:

IMPORTANT! This message contains vital information that must be followed to complete a task.

NOTE: This message contains additional information and tips that can help complete tasks.

WARNING! This message contains important information that must be followed to keep you safe while performing certain tasks and prevent damage to your Single Board Computer's data and components.

Package contents

Your Single Board Computer package contains the following items:

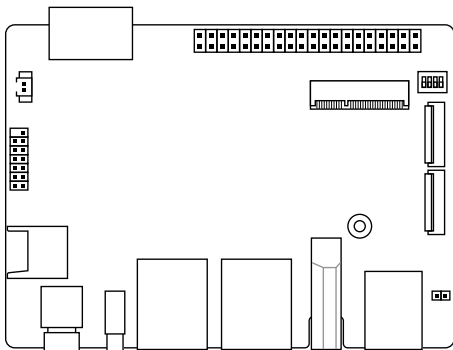

IMX8P-IM-A R2.0

NOTE:

- Some bundled accessories may vary depending on model. For details on these accessories, refer to their respective user manuals.
 - The device illustration is for reference only. Actual product specifications may vary depending on model.
 - If the device or its components fail or malfunction during normal and proper use within the warranty period, bring the warranty card to the ASUS Service Center for replacement of the defective components.
-

1

Specifications Summary

IMX8P-IM-A R2.0 Specifications Summary

		IMX8P-IM-A R2.0
Processor	CPU	NXP® i.MX 8 M ARM Cortex-A53 core
	Max. Speed	1.3 GHz
	L2 Cache	1MB
	Chipset	Integrated
Memory	Technology	LPDDR4
	Max.	4GB, on board memory
Storage	eMMC	1 x 16GB onboard eMMC
Graphics	HDMI™	1 x HDMI™ supports HDMI with max. resolution 3840 x 2160 @ 60 Hz
	MIPI DSI	1 x MIPI DSI supports MIPI DSI (4 lane) with max. resolution 1920 x 1080 @ 60 Hz
Expansion slot	M.2	1 x M.2 2230 E Key for BT/WiFi module (cooperate with Google EdgeTPU Module)
	Others	1 x Micro-SD Card slot
Ethernet	Speed	10/100/1000Mbps
	Controller	1 x Realtek® RTL8211
		1 x Intel® I210-AT
Connector	2 x RJ-45	
Front I/O		1 x HDMI™ 2 x USB 3.2 Gen 1 Type-A ports 1 x USB 3.2 Gen 1 Type-C® OTG port 2 x Ethernet ports 1 x Power button 1 x Reset button
Rear I/O		1 x DC-in jack

(continued on the next page)

		IMX8P-IM-A R2.0
Internal Connector		1 x 40-pin GPIO header: <ul style="list-style-type: none"> - up to 6 x GPIO pins - up to 2 x I2C bus pins - up to 1 x UART pins - up to 2 x PWM pins - up to 1 x PCM/I2S pins - 2 x 5V power pins - 2 x 3.3V power pins - 8 x ground pins 1 x Micro-SD card slot 1 x 14-1 pin TPM header 1 x MIPI DSI supports MIPI DSI (4 lane) with max.1920 x 1080 @ 60 Hz 2 x MIPI CSI support two MIPI-CSI camera inputs (4-lane each)
Watchdog Timer (H/W)		Yes
Security Module	TPM	TPM 2.0 power by Nuvoton NCPT 750 (Optional)
Manageability		WOL
Power	Power Type	DC power input
	Voltage	12-24V DC input
Operating System		Linux Linux Yocto 64-bit
Environment		Operating Temperature: -20~60° C Non-Operating Temperature: -40~85° C Relative Humidity: 10%~95%
Dimension	Form Factor	100mm x 72mm x 21mm
Certification	Safety	CE, FCC

NOTE: Specifications are subject to change without notice.

2

Product Introduction

2.1 Before you proceed

Take note of the following precautions before you install motherboard components or change any motherboard settings.

NOTE: The diagrams in this chapter are for reference only. The motherboard layout may vary with models.

IMPORTANT! Components shown in this section may require additional purchase. Refer to **Package contents** section for more information about the contents of your Single Board Computer package.

WARNING!

- Unplug the power cord from the wall socket before touching any component.
 - Before handling components, use a grounded wrist strap or touch a safely grounded object or a metal object, such as the power supply case, to avoid damaging them due to static electricity.
 - Hold components by the edges to avoid touching the ICs on them.
 - Whenever you uninstall any component, place it on a grounded antistatic pad or in the bag that came with the component.
 - Before you install or remove any component, ensure that the power cord is detached from the power supply. Failure to do so may cause severe damage to the motherboard, peripherals, or components.
-

2.2 Motherboard layout

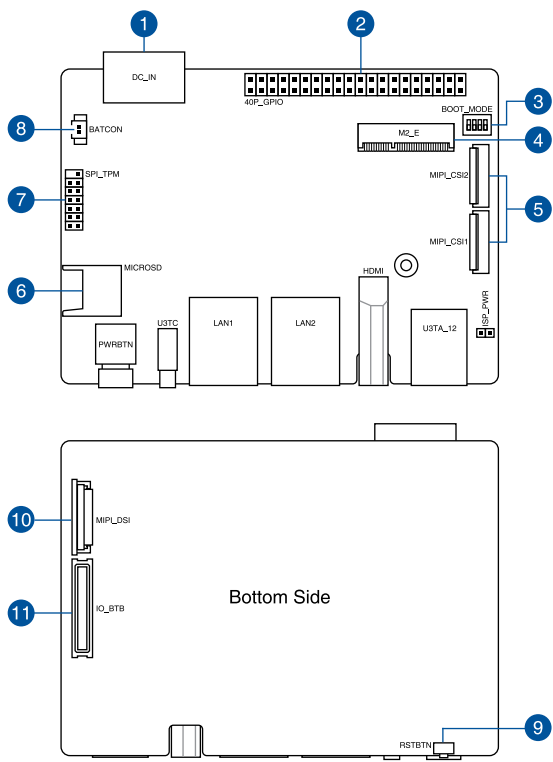

Layout contents		Page
1.	DC-in Power connector	17
2.	GPIO header	18
3.	Boot Mode switch	15
4.	M.2 Wi-Fi slot	20
5.	MIPI CSI connector	21
6.	Micro SD card slot	22
7.	SPI TPM header	23
8.	RTC Battery connector	23
9.	Reset button	16
10.	MIPI DSI connector	24
11.	IO Board-to-Board connector	25

2.3 Onboard button and switches

1. Boot Mode switch

The Boot Mode switch allows you to configure between different boot modes and the location to boot from. Please refer to the table below for the different boot modes.

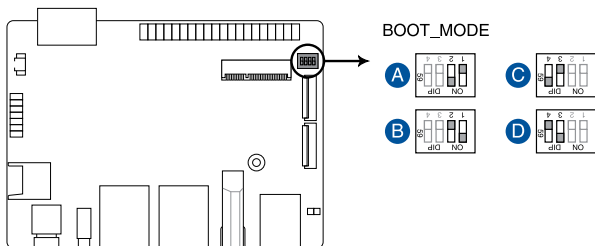

Boot Mode			Boot type
	1	2	
A	OFF	ON	Serial Downloader
B	ON	OFF	Internal Boot (default)
Boot Mode			Boot type
	3	4	
C	OFF	ON	eMMC (default)
D	ON	OFF	SD

2. Reset button

Press the Reset button to reboot the system.

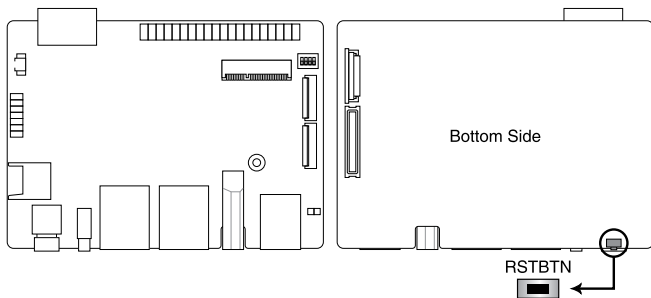

2.4 Internal connectors

1. DC-in Power connector

The DC-in Power connector is for DC power input. Using a compatible power cable, connect the Pico-ITX board to a power supply.

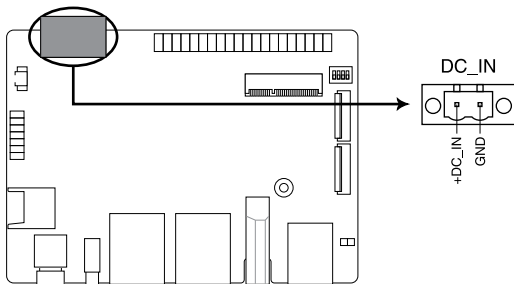

Connector type

POWER CON 2P R/A

Power Requirement

Rating Voltage	12 ~ 24VDC
Rating Current	5.417A ~ 3.42A
Power	65W (recommended)

2. GPIO header

This 40-pin GPIO (General-purpose Input/Output) header can be designated (in software) as an input or output pin and is used for a wide range of purposes. Of the 40 pins, 28 are GPIO pins (shared with SPI/UART/I2C pins). Please refer to the table below for the pin definitions for Linux Yocto.

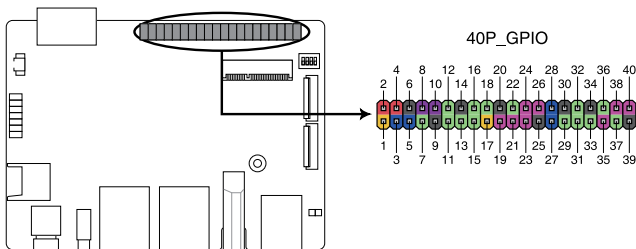

Linux Yocto					
Pin definition	Pin#	40P GPIO		Pin#	Pin definition
3V		1	2		
I2C2_SDA (default) ENET1_1588_EVENT1_OUT GPIO5_IO17	145	3	4		5V
I2C2_SCL (default) ENET1_1588_EVENT1_IN GPIO5_IO16	144	5	6		GND
UART3_TX UART1_RTS_B (default) GPIO5_IO27	155	7	8	151	UART1_TX (default) ECSPI3_MOSI GPIO5_IO23
GND		9	10	150	UART1_RX (default) ECSPI3_SCLK GPIO5_IO22
UART3_RX UART1_CTS_B (default) GPIO5_IO26	154	11	12	121	SAI2_TX_BCLK (default) SAI5_TX_DATA2 GPIO4_IO25
JTAG_TMS		13	14		GND
JTAG_TRST		15	16	86	SAI5_RX_DATA1 SAI1_TX_DATA3 SAI1_TX_SYNC SAI5_TX_SYNC GPIO3_IO22 (default)

(continued on the next page)

Linux Yocto					
Pin definition	Pin#	40P GPIO		Pin#	Pin definition
3V		17	18	87	SAI5_RX_DATA2 SAI1_TX_DATA4 SAI1_TX_SYNC SAI5_TX_BCLK GPIO3_IO23 (default)
ECSPI2_MOSI (default) UART4_TX GPIO5_IO11	139	19	20		GND
ECSPI2_MISO (default) UART4_CTS_B GPIO5_IO12	140	21	22		JTAG_TCK
ECSPI2_SCLK (default) UART4_RX GPIO5_IO10	138	23	24	141	ECSPI2_SS0 (default) UART4_RTS_B GPIO5_IO13
GND		25	26	68	RAWNAND_CE3_B QSPI_B_SS1_B (default) GPIO3_IO04
I2C3_SDA (default) PWM3_OUT GPT3_CLK GPIO5_IO19	147	27	28	146	I2C3_SCL (default) PWM4_OUT GPT2_CLK GPIO5_IO18
JTAG_TDO		29	30		GND
SAI5_RX_DATA3 SAI1_TX_DATA5 SAI1_TX_SYNC SAI5_TX_DATA0 GPIO3_IO24 (default)	88	31	32	131	SPDIF1_OUT PWM3_OUT (default) GPIO5_IO03
SAI3_MCLK PWM4_OUT (default) SAI5_MCLK GPIO5_IO02	130	33	34		GND
SAI2_TX_SYNC (default) SAI5_TX_DATA1 GPIO4_IO24	120	35	36	85	SAI5_RX_DATA0 SAI1_TX_DATA2 GPIO3_IO21 (default)
JTAG_TDI		37	38	119	SAI2_RX_DATA0 (default) SAI5_TX_DATA0 GPIO4_IO23
GND		39	40	122	SAI2_TX_DATA0 (default) SAI5_TX_DATA3 GPIO4_IO26

3. M.2 Wi-Fi slot

The M.2 Wi-Fi slot allows you to install an M.2 Wi-Fi module (E-key, type 2230).

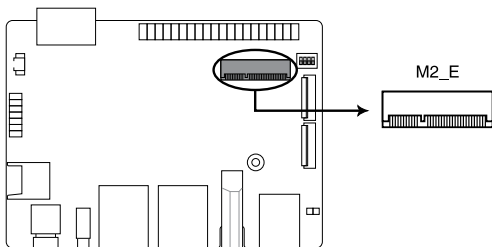

NOTE: The M.2 Wi-Fi module is purchased separately.

4. MIPI CSI connector

This connector connects to camera module via a four lane MIPI CSI-2 cable. This connector supports up to 80Mbps connection speed - 1.5Gbps per lane, providing 4K@30fps capability for the 4 lanes.

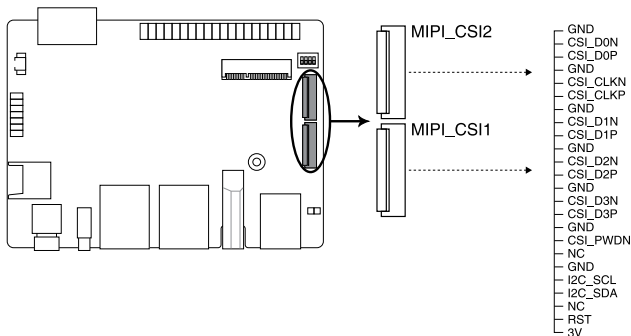

IMPORTANT! Ensure the cable for MIPI CSI is connected in the correct orientation with the gold fingers facing towards the top of the motherboard.

5. Micro SD Card slot

The Micro SD Card slot allows you to install a Micro SD card.

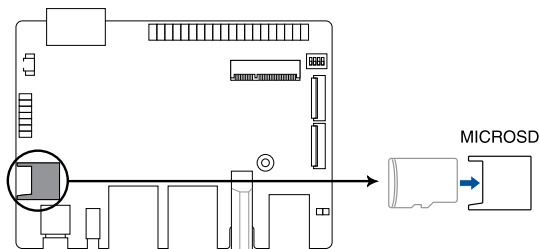

NOTE: The Micro SD card is purchased separately.

6. SPI TPM header

The SPI TPM header supports a Trusted Platform Module (TPM) system, which can securely store keys, digital certificates, passwords, and data. A TPM system also helps enhance network security, protects digital identities, and ensures platform integrity.

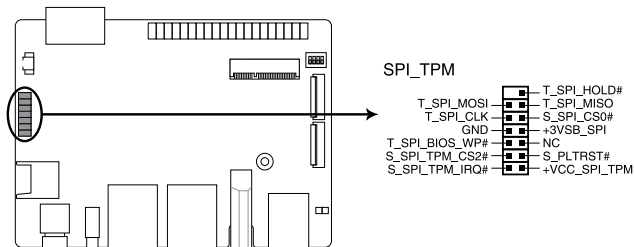

Connector type

Header 2x7p,K14, 2.0mm pitch

7. RTC Battery connector

The RTC Battery connector allows you to connect the lithium CMOS battery.

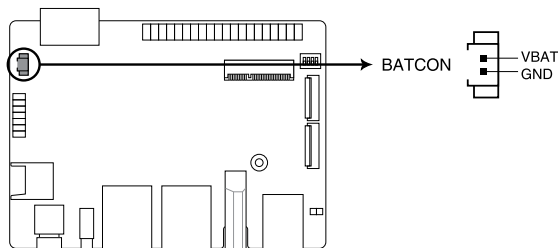

8. MIPI DSI connector

This connector connects to a display module via a four lane MIPI DSI cable. This connector supports up to 1920 x 1080 @ 60 Hz connection speed.

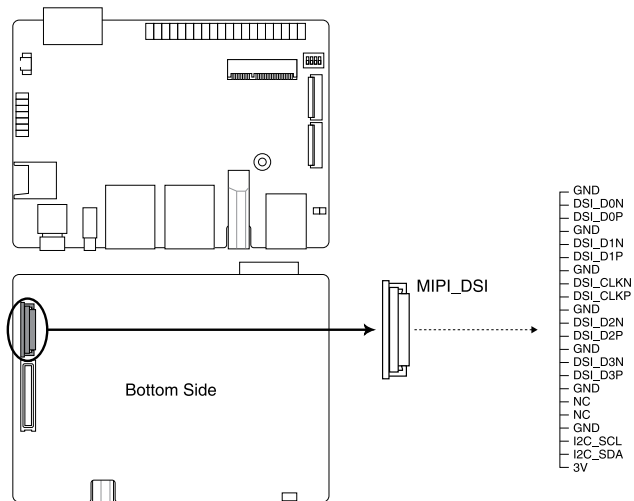

9. IO Board-to-Board connector

The IO Board-to-Board connector allows you to connect the Pico-ITX motherboard and secondary I/O board.

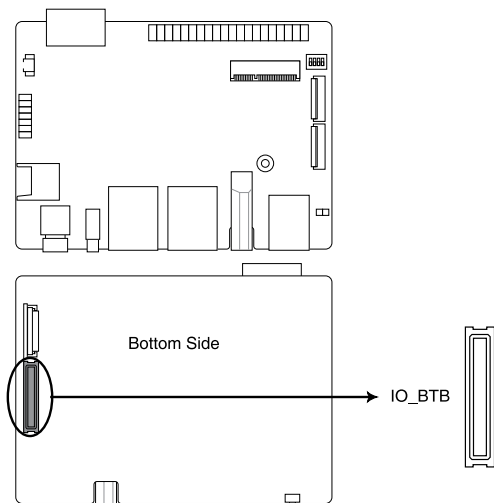

2.5 I/O connectors

Front panel

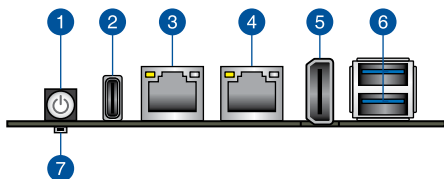

Front panel connectors

- 1 Power button**

The power button allows you to turn the Single Board Computer on or off. You can use the power button to put your Single Board Computer to sleep mode or press it for ten (10) seconds to force shutdown your Single Board Computer.
- 2 USB 3.2 Gen 1 Type-C® OTG port**

This USB Type-C® OTG (Universal Serial Bus) port provides a transfer rate of up to 5 Gbit/s, and provides a maximum of 5V/1.5A output. This port supports OTG mode that can be taken to replace UART debug console.
- 3 LAN port**

The Realtek® RTL8211 Ethernet controllers with 8-pin RJ-45 LAN port supports a standard Ethernet cable for 10/100/1000 Mbps connection to a local network.
- 4 LAN port**

The Intel® I210-AT Gigabit Ethernet controllers with 8-pin RJ-45 LAN port supports a standard Ethernet cable for 10/100/1000 Mbps connection to a local network.
- 5 HDMI™ port**

The integrated 19-pin HDMI (High Definition Multimedia Interface) 2.0 port with a receptacle connector can support resolutions up to 3840 x 2160 @ 60 Hz on external display devices.
- 6 USB 3.2 Gen 1 port**

The USB 3.2 Gen 1 (Universal Serial Bus) port provides a transfer rate up to 5 Gbit/s.

Front panel connectors

7

Reset button

The button allows you to reset the Single Board Computer.

3

Upgrading your Single Board Computer

IMPORTANT!

- Ensure that your hands are dry before proceeding with the rest of the installation process. Before installing any of the features in this guide, use a grounded wrist strap or touch a safely grounded object or metal object to avoid damaging them due to static electricity.
 - Turn off the power of your Single Board Computer, and allow it to cool for at least 10 minutes before performing any installation/uninstallation process.
-

NOTE: The illustrations in this section are for reference only. The slots may vary depending on model.

3.1 Installing an Micro SD card

Insert your Micro SD card into the Micro SD card slot. Ensure that the Micro SD card is pushed all the way into the Micro SD card slot.

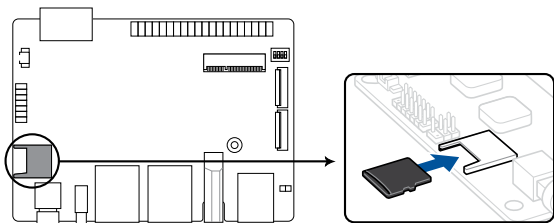

3.2 Installing the wireless card

1. Remove the M.2 stand screw.
 2. Align and insert the wireless card into its slot on the motherboard, then gently push down the wireless card on top of the screw hole and fasten it using the previously removed stand screw.
 3. (optional) Connect the antennas to your wireless card.
-

NOTE:

- Connecting antennas to your wireless card may strengthen the wireless signal.
 - A soft clicking sound indicates that the antenna has been securely attached on the wireless card.
 - The antennas are purchased separately.
-

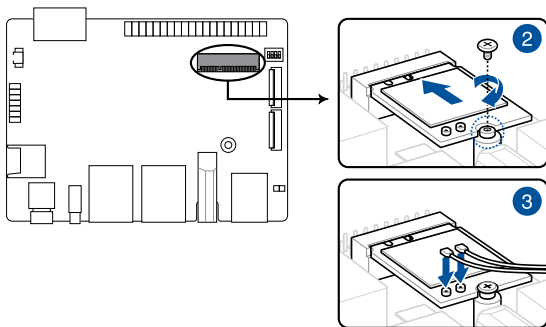

Appendix

Safety information

Your Edge Computer is designed and tested to meet the latest standards of safety for information technology equipment. However, to ensure your safety, it is important that you read the following safety instructions.

Setting up your system

- Read and follow all instructions in the documentation before you operate your system.
- Do not use this product near water or a heated source.
- Set up the system on a stable surface.
- Peripherals with extended temperature tolerance (such as industrial grade mSATA, Micro SD card, etc.) will allow this product to be used in environments with ambient temperatures between -20°C and 60°C, with air flow.
- The product should be used in environments with an ambient temperature of 40°C when using the 65W adapter.
- If you use an extension cord, make sure that the total ampere rating of the devices plugged into the extension cord does not exceed its ampere rating.
- This equipment should be installed and operated with a minimum distance of 20cm between the radiator and your body.
- Restricted Access Location:
The equipment should only be installed in a Restricted Access Area where both these conditions apply:
 - access can only be gained by USERS who have been instructed about the reasons for the restrictions applied to the location and about any precautions that shall be taken; and
 - access is through the use of a TOOL or lock and key, or other means of security, and is controlled by the authority responsible for the location.
- This device shall not be connected to an Ethernet network with outside plant routing.

Care during use

- Do not walk on the power cord or allow anything to rest on it.
- Do not spill water or any other liquids on your system.
- When the system is turned off, a small amount of electrical current still flows. Always unplug the power cord from the power outlets before cleaning the system.
- If you encounter the following technical problems with the product, unplug the power cord and contact a qualified service technician or your retailer.
 - The power cord or plug is damaged.
 - Liquid has been spilled into the system.
 - The system does not function properly even if you follow the operating instructions.
 - The system was dropped or the cabinet is damaged.
 - The system performance changes.

Safety Precautions

Accessories that came with this product have been designed and verified for the use in connection with this product. Never use accessories for other products to prevent the risk of electric shock or fire.

Lithium-Ion Battery Warning

CAUTION: Danger of explosion if battery is incorrectly replaced. Replace only with the same or equivalent type recommended by the manufacturer. Dispose of used batteries according to the manufacturer's instructions.

NO DISASSEMBLY

The warranty does not apply to the products that have been disassembled by users

Regulatory notices

COATING NOTICE

IMPORTANT! To provide electrical insulation and maintain electrical safety, a coating is applied to insulate the device except on the areas where the I/O ports are located.

Federal Communications Commission Statement

This device complies with Part 15 of the FCC Rules. Operation is subject to the following two conditions:

- This device may not cause harmful interference, and
- This device must accept any interference received including interference that may cause undesired operation.

This equipment has been tested and found to comply with the limits for a Class A digital device, pursuant to part 15 of the FCC Rules. These limits are designed to provide reasonable protection against harmful interference when the equipment is operated in a commercial environment.

This equipment generates, uses, and can radiate radio frequency energy and, if not installed and used in accordance with the instruction manual, may cause harmful interference to radio communications. Operation of this equipment in a residential area is likely to cause harmful interference in which case the user will be required to correct the interference at his own expense.

IMPORTANT! Outdoor operations in the 5.15~5.25 GHz band is prohibited. This device has no Ad-hoc capability for 5250~5350 and 5470~5725 MHz.

CAUTION! Any changes or modifications not expressly approved by the grantee of this device could void the user's authority to operate the equipment.

RF exposure warning

This equipment must be installed and operated in accordance with provided instructions and the antenna(s) used for this transmitter must be installed to provide a separation distance of at least 20 cm from all persons and must not be co-located or operating in conjunction with any other antenna or transmitter. End-users and installers must be provide with antenna installation instructions and transmitter operating conditions for satisfying RF exposure compliance.

End Product Labeling

This transmitter module is authorized only for use in device where the antenna may be installed such that 20cm may be maintained between the antenna and users. The final end product must be labeled in a visible area with the following:

Contains FCC ID: TX2-RTL8822CE and Contains IC:6317A-RTL8822CE

ISED Radiation Exposure Statement for Canada

This equipment complies with ISED radiation exposure limits set forth for an uncontrolled environment. To maintain compliance with ISED RF exposure compliance requirements, please avoid direct contact to the transmitting antenna during transmitting. End users must follow the specific operating instructions for satisfying RF exposure compliance.

Operation is subject to the following two conditions:

- This device may not cause interference and
- This device must accept any interference, including interference that may cause undesired operation of the device.

Compliance Statement of Innovation, Science and Economic Development Canada (ISED)

This device complies with Innovation, Science and Economic Development Canada licence exempt RSS standard(s). Operation is subject to the following two conditions: (1) this device may not cause interference, and (2) this device must accept any interference, including interference that may cause undesired operation of the device.

CAN ICES-003(A)/NMB-003(A)

Déclaration de conformité de Innovation, Sciences et Développement économique Canada (ISED)

Le présent appareil est conforme aux CNR d'Innovation, Sciences et Développement économique Canada applicables aux appareils radio exempts de licence. L'exploitation est autorisée aux deux conditions suivantes : (1) l'appareil ne doit pas produire de brouillage, et (2) l'utilisateur de l'appareil doit accepter tout brouillage radioélectrique subi, même si le brouillage est susceptible d'en compromettre le fonctionnement.

CAN ICES-003(A)/NMB-003(A)

Wireless Operation Channel for Different Domains

N. America	2.412-2.462 GHz	Ch01 through CH11
Japan	2.412-2.484 GHz	Ch01 through Ch14
Europe ETSI	2.412-2.472 GHz	Ch01 through Ch13

KC: Korea Warning Statement

Class A:

사용자 안내문

이 기기는 업무용 환경에서 사용할 목적으로 적합성평가를 받은 기기로서 가정용 환경에서 사용하는 경우 전파간섭의 우려가 있습니다.

VCCI: Japan Compliance Statement

Class A ITE

この装置は、クラスA機器です。この装置を住宅環境で使用すると電波妨害を引き起こすことがあります。この場合には使用者が適切な対策を講ずるよう要求されることがあります。

VCCI - A

Japan RF Equipment Statement

屋外での使用について

本製品は、5GHz帯域での通信に対応しています。電波法の定めにより5.2GHz、5.3GHz帯域の電波は屋外で使用が禁じられています。

法律および規制遵守

本製品は電波法及びこれに基づく命令の定めるところに従い使用してください。日本国外では、その国の法律または規制により、本製品の使用ができないことがあります。このような国では、本製品を運用した結果、罰せられることがあります。当社は一切責任を負いかねますのでご了承ください。

HDMI Trademark Notice

The terms HDMI, HDMI High-Definition Multimedia Interface, and the HDMI Logo are trademarks or registered trademarks of HDMI Licensing Administrator, Inc.

Declaration of compliance for product environmental regulation

ASUS follows the green design concept to design and manufacture our products, and makes sure that each stage of the product life cycle of ASUS product is in line with global environmental regulations. In addition, ASUS disclose the relevant information based on regulation requirements.

Please refer to <http://csr.asus.com/Compliance.htm> for information disclosure based on regulation requirements ASUS is complied with:

EU REACH and Article 33

Complying with the REACH (Registration, Evaluation, Authorization, and Restriction of Chemicals) regulatory framework, we publish the chemical substances in our products at ASUS REACH website at

<http://csr.asus.com/english/REACH.htm>

EU RoHS

This product complies with the EU RoHS Directive. For more details, see

<http://csr.asus.com/english/article.aspx?id=35>

Japan JIS-C-0950 Material Declarations

Information on Japan RoHS (JIS-C-0950) chemical disclosures is available on

<http://csr.asus.com/english/article.aspx?id=19>

India RoHS

This product complies with the “India E-Waste (Management) Rules, 2016” and prohibits use of lead, mercury, hexavalent chromium, polybrominated biphenyls (PBBs) and polybrominated diphenyl ethers (PBDEs) in concentrations exceeding 0.1% by weight in homogenous materials and 0.01% by weight in homogenous materials for cadmium, except for the exemptions listed in Schedule II of the Rule.

Vietnam RoHS

ASUS products sold in Vietnam, on or after September 23, 2011, meet the requirements of the Vietnam Circular 30/2011/TT-BCT.

Các sản phẩm ASUS bán tại Việt Nam, vào ngày 23 tháng 9 năm 2011 trở về sau, đều phải đáp ứng các yêu cầu của Thông tư 30/2011/TT-BCT của Việt Nam.

Türkiye RoHS

AEEE Yönetmeliğine Uygundur

ASUS Recycling/Takeback Services

ASUS recycling and takeback programs come from our commitment to the highest standards for protecting our environment. We believe in providing solutions for you to be able to responsibly recycle our products, batteries, other components as well as the packaging materials. Please go to <http://csr.asus.com/english/Takeback.htm> for detailed recycling information in different regions.

Ecodesign Directive

European Union announced a framework for the setting of ecodesign requirements for energy-related products (2009/125/EC). Specific Implementing Measures are aimed at improving environmental performance of specific products or across multiple product types. ASUS provides product information on the CSR website. The further information could be found at <https://csr.asus.com/english/article.aspx?id=1555>.



DO NOT throw the Edge Computer in municipal waste. This product has been designed to enable proper reuse of parts and recycling.

This symbol of the crossed out wheeled bin indicates that the product (electrical, electronic equipment, and mercury-containing button cell battery) should not be placed in municipal waste. Check local technical support services for product recycling.

Service and Support

Visit our multi-language website at <https://www.asus.com/support>.

