

Q470EI-IM-A

Industrial Motherboard

Copyright © 2023 ASUSTeK COMPUTER INC. All Rights Reserved.

No part of this manual, including the products and software described in it, may be reproduced, transmitted, transcribed, stored in a retrieval system, or translated into any language in any form or by any means, except documentation kept by the purchaser for backup purposes, without the express written permission of ASUSTeK COMPUTER INC. ("ASUS").

Product warranty or service will not be extended if: (1) the product is repaired, modified or altered, unless such repair, modification or alteration is authorized in writing by ASUS; or (2) the serial number of the product is defaced or missing.

ASUS PROVIDES THIS MANUAL "AS IS" WITHOUT WARRANTY OF ANY KIND, EITHER EXPRESS OR IMPLIED, INCLUDING BUT NOT LIMITED TO THE IMPLIED WARRANTIES OR CONDITIONS OF MERCHANTABILITY OR FITNESS FOR A PARTICULAR PURPOSE. IN NO EVENT SHALL ASUS, ITS DIRECTORS, OFFICERS, EMPLOYEES OR AGENTS BE LIABLE FOR ANY INDIRECT, SPECIAL, INCIDENTAL, OR CONSEQUENTIAL DAMAGES (INCLUDING DAMAGES FOR LOSS OF PROFITS, LOSS OF BUSINESS, LOSS OF USE OR DATA, INTERRUPTION OF BUSINESS AND THE LIKE), EVEN IF ASUS HAS BEEN ADVISED OF THE POSSIBILITY OF SUCH DAMAGES ARISING FROM ANY DEFECT OR ERROR IN THIS MANUAL OR PRODUCT.

SPECIFICATIONS AND INFORMATION CONTAINED IN THIS MANUAL ARE FURNISHED FOR INFORMATIONAL USE ONLY, AND ARE SUBJECT TO CHANGE AT ANY TIME WITHOUT NOTICE, AND SHOULD NOT BE CONSTRUED AS A COMMITMENT BY ASUS. ASUS ASSUMES NO RESPONSIBILITY OR LIABILITY FOR ANY ERRORS OR INACCURACIES THAT MAY APPEAR IN THIS MANUAL, INCLUDING THE PRODUCTS AND SOFTWARE DESCRIBED IN IT.

Products and corporate names appearing in this manual may or may not be registered trademarks or copyrights of their respective companies, and are used only for identification or explanation and to the owners' benefit, without intent to infringe.

Contents

Chapter 1	Product overview	
1.1	Package contents.....	1-1
1.2	Features	1-1
1.3	Specifications.....	1-2
Chapter 2	Motherboard information	
2.1	Before you proceed	2-1
2.2	Motherboard layout.....	2-2
2.3	Central Processing Unit (CPU)	2-4
2.3.1	CPU installation	2-5
2.3.2	CPU heatsink and fan assembly installation.....	2-7
2.4	System memory	2-9
2.5	Jumpers	2-10
2.6	Connectors	2-14
2.6.1	Rear panel connectors.....	2-14
2.6.2	Internal connectors	2-16
Chapter 3	BIOS setup	
3.1	BIOS Setup program.....	3-1
3.2	Main menu	3-2
3.2.1	System Date [Day MM/DD/YYYY]	3-2
3.2.2	System Time [HH:MM:SS].....	3-2
3.3	Advanced menu	3-2
3.3.1	LVDS Configuration	3-2
3.3.2	PCH-FW Configuration	3-4
3.3.3	Trusted Computing	3-4
3.3.4	CPU Configuration	3-5
3.3.5	Graphics Configuration	3-6
3.3.6	PCI Express Configuration.....	3-6
3.3.7	AMT Configuration	3-8
3.3.8	CSM Configuration.....	3-8
3.3.9	Super IO Configuration	3-9
3.3.10	Serial Console Redirection	3-10
3.3.11	SATA And RST Configuration.....	3-12
3.3.12	Network Stack Configuration	3-13
3.3.13	USB Configuration	3-13

3.3.14	NVMe Configuration.....	3-14
3.3.15	Onboard Devices Configuration.....	3-14
3.3.16	EZ-Flash	3-15
3.3.17	APM Configuration.....	3-15
3.3.18	Watchdog Timer.....	3-16
3.3.19	Miscellaneous	3-16
3.4	Hardware Monitor menu	3-17
3.4.1	Smart Fan Mode	3-17
3.4.2	Smart Fan Function	3-17
3.5	Security menu	3-17
3.5.1	Administrator Password.....	3-17
3.5.2	User Password.....	3-18
3.5.3	Secure Boot	3-18
3.6	Boot menu	3-19
3.7	Exit menu.....	3-20

Appendix

Notices.....	A-1
Service and Support.....	A-5

Chapter 1

Product overview

1.1 Package contents

Check your industrial motherboard package for the following items.

- 1 x ASUS Q470EI-IM-A Motherboard
- 2 x Serial ATA 6.0 Gb/s cables
- 2 x M.2 screw packages
- 1 x ASUS I/O Shield



NOTE: If any of the above items is damaged or missing, contact your distributor or sales representative immediately.

1.2 Features

- Intel® socket 1200 for 10th Gen Intel® Core™ i9/ i7/ i5/ i3, Pentium®, and Celeron® processors
- Two Dual Channel DDR4 2933/2666/2400/2133 MHz SO-DIMMs up to 64GB
- 3 x SATA 6.0 Gb/s, 3 x USB 3.2 Gen 2, 4 x USB 3.2 Gen 1, 6 x USB 2.0, 5 x COM ports
- 1 x PCIe x16 slot, 1 x M.2 (Key E, 2230) for WiFi/BT device, 1 x M.2 (Key M, 2242/2260/2280) with PCIe and SATA modes for SSD
- Multi-display: 2 x DisplayPorts, 1 x DVI-D, LVDS/eDP

1.3 Specifications

CPU	Intel® socket 1200 for 10th Gen Intel® Core™ i9/ i7/ i5/ i3, Pentium®, and Celeron® processors Supports Intel® 14nm CPU Supports up to 65W TDP
Chipset	Intel® Q470E Chipset
Memory	2 x SO-DIMM, max. 64GB, DDR4 2933/2666/2400/2133 MHz SDRAM
Graphics	Integrated graphics processor - Intel® HD Graphics support Multi-VGA output support: DP/DVI-D/LVDS ports <ul style="list-style-type: none"> - Supports 2x DisplayPort 1.4a outputs with a maximum resolution of 4096 x 2160 @60 Hz - Supports DVI-D output with a maximum resolution of 1920 x 1200 @60Hz - Supports LVDS output with a maximum resolution of 1920 x 1200 @60Hz - 4 lanes Embedded Display Port output with a maximum resolution of 3840 x 2160 @60Hz (co-lay with LVDS)
Expansion slots	1 x PCI Express 3.0/2.0 x16 slot* 1 x M.2 socket 1 (Key E, 2230) with PCIe and CNVI modes for WiFi/BT device 1 x M.2 socket 3 (Key M, 2242/2260/2280) with PCIe and SATA modes * Supports PCIe bifurcation (16x to 8x+8x / 8x+4x+4x).
Storage	3 x SATA 6.0 Gb/s ports 1 x M.2 socket 3 (Key M, 2242/2260/2280) with PCIe and SATA modes
LAN	Dual Intel® Lan: 1 x Intel® I219LM, 1 x Intel® I210AT
Audio	Realtek ALC887 / ALC897 High Definition Audio CODEC* * The audio codec may vary between motherboards, please consult your sales window for the motherboard's exact codec type.
Rear panel I/O ports	1 x DVI-D port 2 x DisplayPorts 3 x USB 3.2 Gen 2 ports (2 x Type-A + 1 x Type-C®) 1 x USB 3.2 Gen 1 port 4 x USB 2.0 ports 2 x LAN (RJ45) ports 1 x P/S2 keyboard port 1 x P/S2 mouse port 1 x COM port (RS232/422/485) 2 x Audio jacks

(continued on the next page)

Internal I/O ports	4 x COM Port headers (1 x RS232/422/485, 3 x RS232)
	1 x USB 3.2 Gen 1 connector supports additional 2 USB 3.2 Gen 1 ports
	1 x USB 3.2 Gen 1 stick socket
	1 x USB 2.0 connector supports additional 2 USB 2.0 ports
	1 x CPU Fan connector with PWM mode
	1 x Chassis Fan connector with PWM mode
	1 x Disable ME connector
	1 x LVDS/eDP Signal connector
	1 x LVDS/eDP Backlight panel connector
	1 x I ² C connector
	1 x LCD panel monitor switch header
	1 x Front panel audio header (AAFP)
	1 x System panel header
	1 x S/PDIF connector
	1 x Chassis intrusion header
	1 x Speaker connector
	1 x Clear CMOS header
	1 x LPC Debug header
	1 x AT/ATX mode selection header
	1 x 24-pin ATX power connector
	1 x 8-pin ATX power connector
1 x Display panel VCC power selection header	
1 x M.2 socket 1 (Key E, 2230) with PCIe and CNVI modes for WiFi/BT device	
1 x M.2 socket 3 (Key M, 2242/2260/2280) with PCIe and SATA modes	
1 x WDT Enable header	
3 x SATA 6.0Gb/s connectors	
1 x TPM connector	
1 x RTC Battery connector	
1 x LVDS/eDP Panel Enable Signal Selection header	
GPIO	1 x 8-bit GPIO header
Manageability	WfM 2.0, DMI 2.0, WOL by PME
Watch dog timer	Yes
Power requirement	ATX mode 12V DC-IN (Supported by an additional cable)
Operation Temperature	0~60°C
Non-Operation Temperature	-40~85°C

(continued on the next page)

Relative Humidity	0%~85%
OS support	Windows® 10 (64-bit) Windows® IoT Enterprise Ubuntu RedHat Enterprise Fedora Workstation OpenSUSE
Certification	CE, FCC, UL
Form Factor	Mini-ITX Form Factor, 6.7"x 6.7" (17.0cm x 17.0cm)



NOTE: Specifications are subject to change without notice. Please refer to the ASUS website for the latest specifications.

Chapter 2

Motherboard information

2.1 Before you proceed

Take note of the following precautions before you install motherboard components or change any motherboard settings.



CAUTION!

- Unplug the power cord from the wall socket before touching any component.
 - Before handling components, use a grounded wrist strap or touch a safely grounded object or a metal object, such as the power supply case, to avoid damaging them due to static electricity.
 - Hold components by the edges to avoid touching the ICs on them.
 - Whenever you uninstall any component, place it on a grounded antistatic pad or in the bag that came with the component.
 - Before you install or remove any component, always remove the AC power by unplugging the power cord from the power outlet. Failure to do so may cause severe damage to the motherboard, peripherals, or components.
-

2.2 Motherboard layout



NOTE: Place four screws into the holes indicated by circles to secure the motherboard to the chassis.



CAUTION! Do not overtighten the screws! Doing so can damage the motherboard.

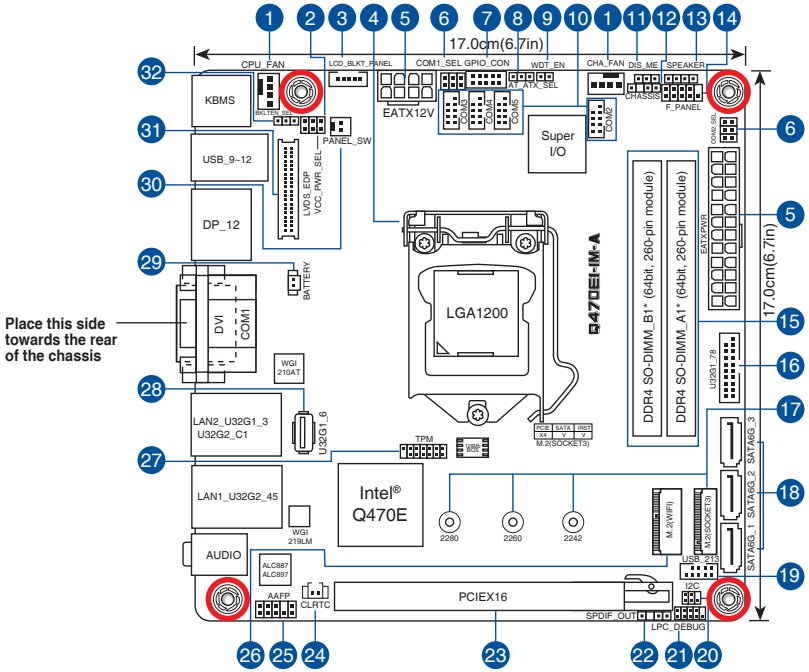

Connectors/Jumpers/Slots	Page
1. CPU and chassis fan connectors (4-pin CPU_FAN, 4-pin CHA_FAN)	2-18
2. Display panel VCC power selection (6-pin VCC_PWR_SEL)	2-10
3. LVDS/eDP Backlight panel connector (5-pin LCD_BLK_PANEL)	2-23
4. Intel® LGA1200 CPU socket	2-4
5. ATX power connectors (24-pin EATXPWR, 8-pin EATX12V)	2-25
6. COM1/2 Ring/+5V/+12V selection jumpers (6-pin COM1_SEL, COM2_SEL)	2-10
7. General purpose input/output connector (10-pin GPIO_CON)	2-17
8. AT/ATX mode selection (3-pin AT_ATX_SEL)	2-11
9. WDT Enable jumper (2-pin WDT_EN)	2-11
10. Serial port connectors (10-1 pin COM2, COM3, COM4, COM5)	2-23
11. Disable ME connector (3-pin DIS_ME)	2-12
12. Chassis Intrusion header (4-1 pin CHASSIS)	2-12
13. Speaker connector (4-pin SPEAKER)	2-20
14. System panel connector (10-1 pin F_PANEL)	2-19
15. DDR4 SO-DIMM slots	2-9
16. USB 3.2 Gen 1 connector (20-1 pin U32G1_78)	2-16
17. M.2 socket 3	2-21
18. SATA 6.0Gb/s connectors (7-pin SATA6G_1-3)	2-20
19. USB 2.0 connector (10-1 pin USB_213)	2-17
20. I ² C connector (6-pin I2C)	2-22
21. LPC debug header (10-1 pin LPC_DEBUG)	2-22
22. Digital audio connector (4-1 pin SPDIF_OUT)	2-24
23. PCI Express 3.0/2.0 x16 slot	
24. Clear CMOS header (2-pin CLRRTC)	2-13
25. Front panel audio connector (10-1 pin AAFP)	2-24
26. M.2 Wi-Fi	2-21
27. TPM connector (14-1 pin TPM)	2-18
28. USB 3.2 Gen 1 port (U32G1_6)	2-16
29. RTC Battery header (2-pin BATTERY)	2-21
30. LCD panel monitor switch header (2-pin PANEL_SW)	2-16
31. LVDS/eDP Signal connector (LVDS_EPD)	2-20
32. LVDS/eDP Panel Enable Signal Selection header (3-pin BKLTEN_SEL)	2-13

2.3 Central Processing Unit (CPU)

The motherboard comes with a surface mount LGA1200 socket designed for the Intel® 10th Generation Intel® Core™ i9 / Core™ i7 / Core™ i5 / Core™ i3, Pentium®, and Celeron® processors.

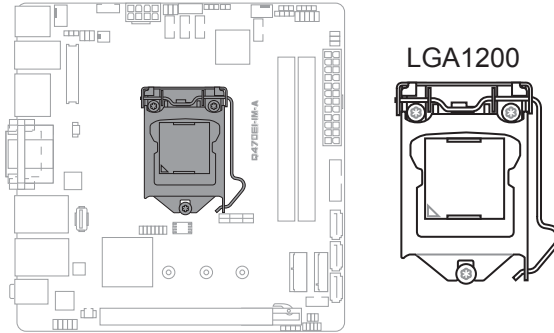

IMPORTANT! Unplug all power cables before installing the CPU.



CAUTION!

- Upon purchase of the motherboard, ensure that the PnP cap is on the socket and the socket contacts are not bent. Contact your retailer immediately if the PnP cap is missing, or if you see any damage to the PnP cap/socket contacts/motherboard components. The manufacturer will shoulder the cost of repair only if the damage is shipment/transit-related.
 - Keep the cap after installing the motherboard. The manufacturer will process Return Merchandise Authorization (RMA) requests only if the motherboard comes with the cap on the LGA1200 socket.
 - The product warranty does not cover damage to the socket contacts resulting from incorrect CPU installation/removal, or misplacement/loss/incorrect removal of the PnP cap.
-

2.3.1 CPU installation

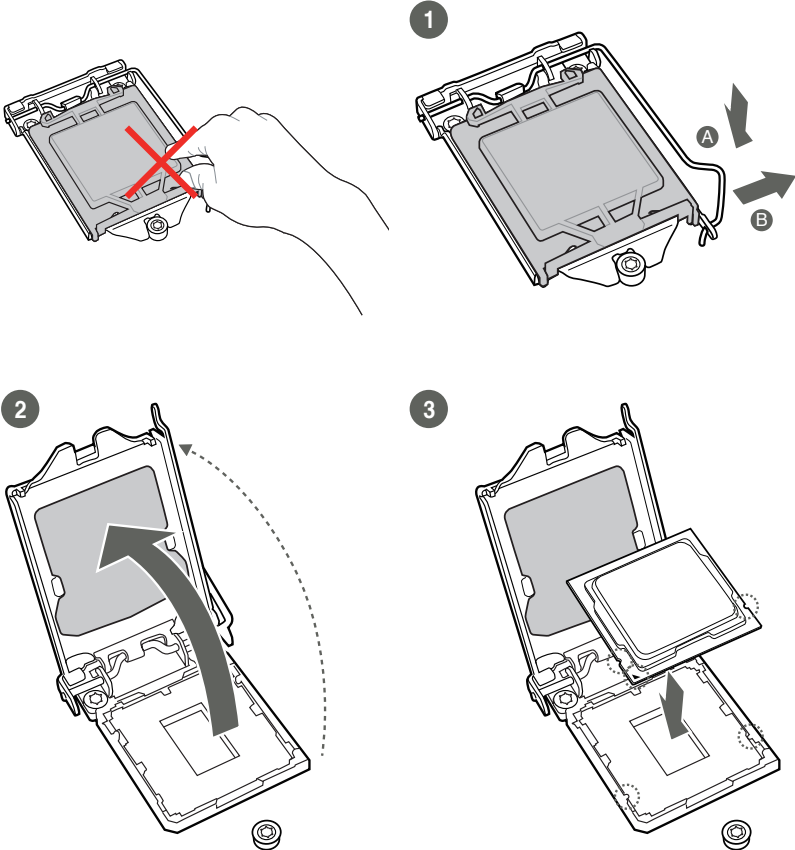

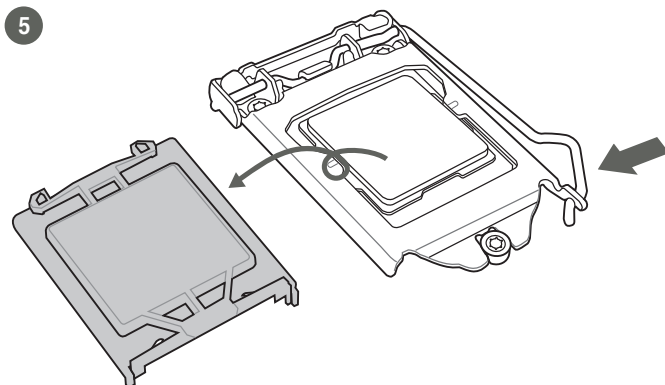
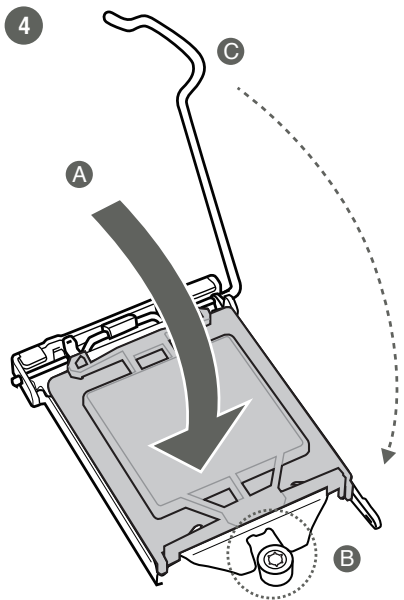

2.3.2 CPU heatsink and fan assembly installation

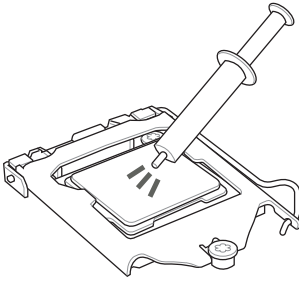

CAUTION! Apply the Thermal Interface Material to the CPU heatsink and CPU before you install the heatsink and fan if necessary.

To install the CPU heatsink and fan assembly

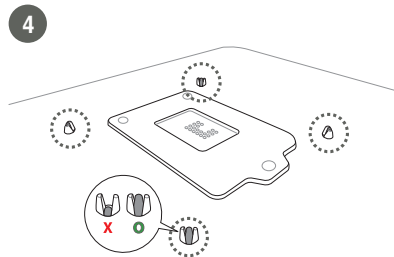
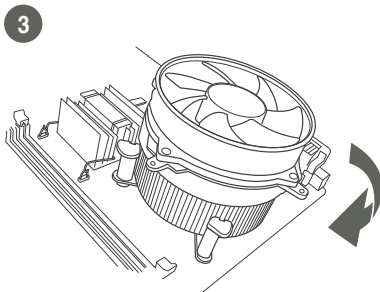
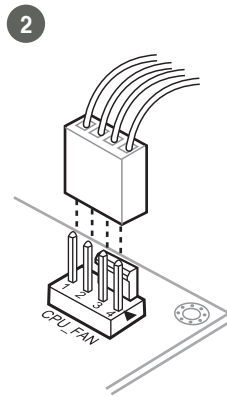
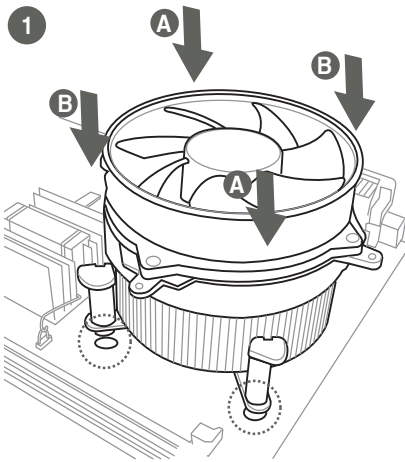

To uninstall the CPU heatsink and fan assembly

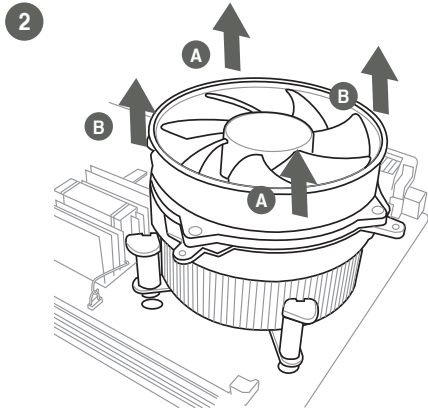
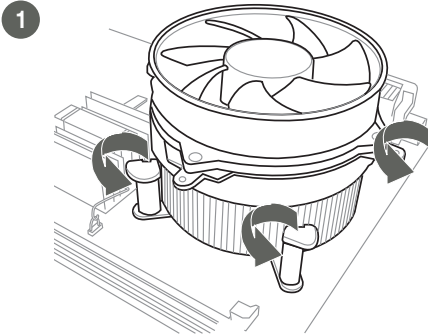

2.4 System memory

This motherboard comes with two Double Data Rate 4 (DDR4) Small Outline Dual Inline Memory Module (SO-DIMM) sockets. The figure below illustrates the location of the DDR4 SO-DIMM sockets:

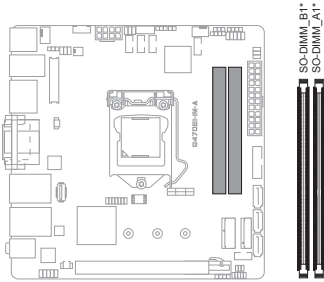

Channel	Sockets
Channel A	SO-DIMM_B1*
Channel B	SO-DIMM_A1*

Recommended memory configuration

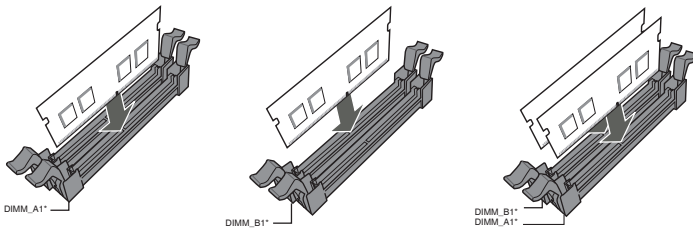

Installing a DIMM

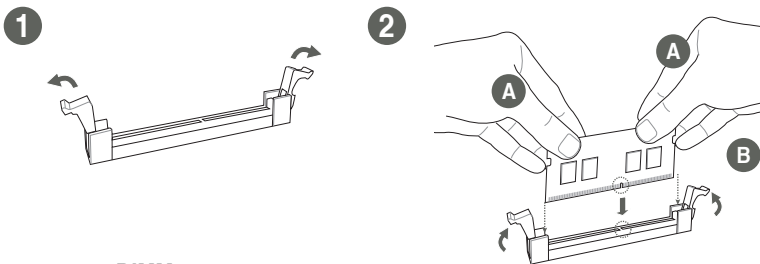

To remove a DIMM

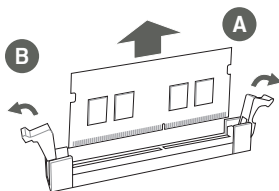

2.5 Jumpers

1. Display panel VCC power selection (6-pin VCC_PWR_SEL)

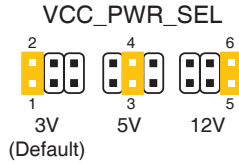
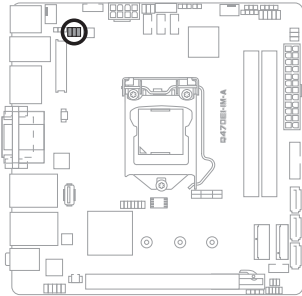

Setting	Pins
3V (Default)	1-2
5V	3-4
12V	5-6

Connector type HEADER 2 x 3p, 2.54mm pitch, S/T

2. COM1/2 Ring/+5V/+12V selection (6-pin COM1_SEL, COM2_SEL)

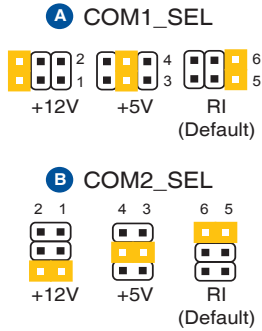
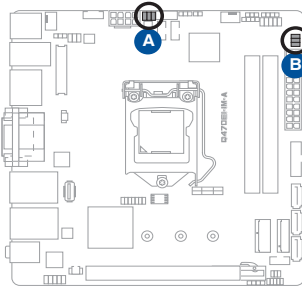

Setting	Pins
+12V	1-2
+5V	3-4
Ring (Default)	5-6

Connector type HEADER 2x3p, 2.54mm pitch, S/T

3. AT/ATX mode selection (3-pin AT_ATX_SEL)

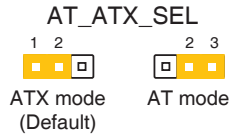
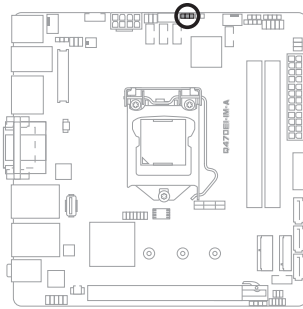

Pins	
1-2 (Default)	ATX mode
2-3	AT mode

Connector type HEADER 1x3p, 2.54mm pitch, S/T

4. WDT Enable jumper (2-pin WDT_EN)

A watchdog timer is an electronic timer that is used to detect and recover from computer malfunctions. The HW WDT (watchdog timer) Enable jumper allows the HW watchdog resets the system automatically even when the system crashes.

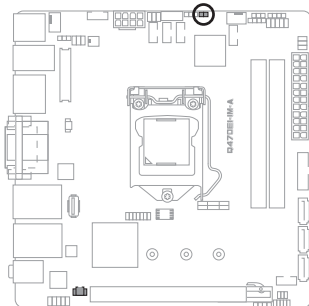

Connector type HEADER 1x2p, 2.54mm pitch, S/T



NOTE: By default, this jumper is set to HW WDT enabled with a jumper cap attached.

5. Disable ME jumper (3-pin DIS_ME)

This jumper allows you to enable or disable the Intel® ME function. Set this jumper to pins 1-2 to enable (default) the Intel® ME function and to pins 2-3 to disable it.

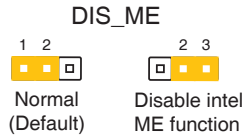
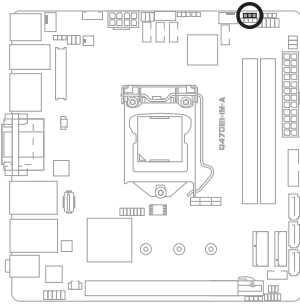

Connector type HEADER 1x3p, 2.54mm pitch, S/T

6. Chassis intrusion header (4-1 pin CHASSIS)

This header is for a chassis-mounted intrusion detection sensor or switch. Connect one end of the chassis intrusion sensor or switch cable to this connector. The chassis intrusion sensor or switch sends a high-level signal to this connector when a chassis component is removed or replaced. The signal is then generated as a chassis intrusion event.

By default, the pin labeled “Chassis Signal” and “Ground” are shorted with jumper caps. Remove the jumper caps only when you intend to use the chassis intrusion detection feature.

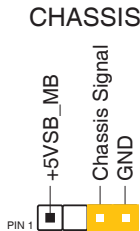
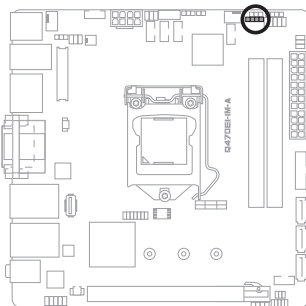

Connector type HEADER 4p, K2, 2.54mm pitch

7. Clear CMOS header (2-pin CLRTC)

This header allows you to clear the CMOS RTC RAM data of the system setup information such as date, time, and system passwords.

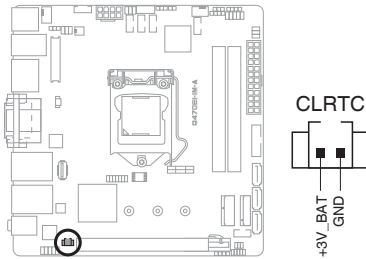

Connector type HEADER 1x2p, 1.25mm pitch, S/T

To erase the RTC RAM:

1. Turn OFF the computer and unplug the power cord.
2. Use a metal object such as a screwdriver to short the two pins.
3. Plug the power cord and turn ON the computer.
4. Hold down the key during the boot process and enter BIOS Setup to re-enter data.



NOTE: If the steps above do not help, remove the onboard battery and move the jumper again to clear the CMOS RTC RAM data. After clearing the CMOS, reinstall the battery.

8. LVDS/eDP Panel Enable Signal Selection header (BKLTEN_SEL)

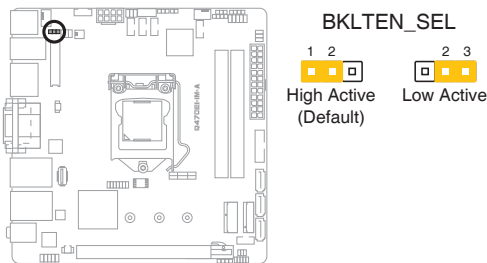

Pins	
1-2 (Default)	High Active
2-3	Low Active

Connector type HEADER 1x3p, 2.54mm pitch, S/T

2.6 Connectors

2.6.1 Rear panel connectors

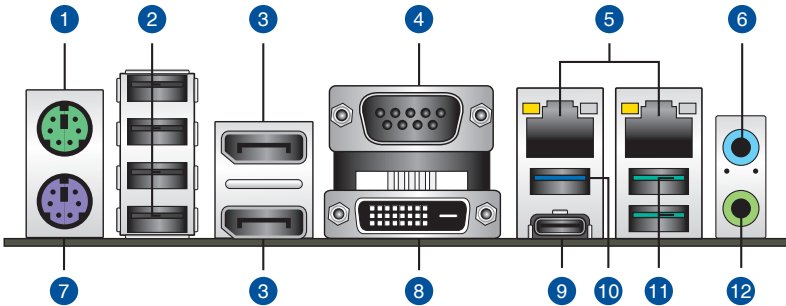

1. **PS/2 mouse port (green).** This port is for a PS/2 mouse.
2. **USB 2.0 ports.** These 4-pin Universal Serial Bus (USB) ports are for USB 2.0/1.1 devices.
3. **DisplayPorts.** These ports are for DisplayPort-compatible devices.
4. **Serial port (COM).** This port connects a modem or other device that conforms with serial specification.

Pin	Pin Definition		
	RS-232	RS-422	RS-485
1	DCD	TX-	DATA-
2	RXD	TX+	DATA+
3	TXD	RX+	NC
4	DTR	RX-	NC
5	GND	GND	GND
6	DSR	NC	NC
7	RTS	NC	NC
8	CTS	NC	NC
9	RI	NC	NC

5. **LAN (RJ-45) ports.** These ports allow Gigabit connection to a Local Area Network (LAN) through a network hub.

LAN port LED indications

Activity/Link LED		Speed LED	
Status	Description	Status	Description
Off	No link	OFF	10Mbps connection
Orange	Linked	ORANGE	100Mbps connection
Orange (Blinking)	Data activity	GREEN	1Gbps connection
Orange (Blinking then steady)	Ready to wake up from S5 mode		

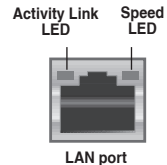

6. **Line In port (light blue).** This port connects to the tape, CD, DVD player, or other audio sources.
7. **PS/2 keyboard port (purple).** This port is for a PS/2 keyboard.
8. **DVI-D port.** This port is for any DVI-D compatible device.



DVI-D can not be converted to output from RGB Signal to CRT and is not compatible with DVI-I.

9. **USB 3.2 Gen 2 (up to 10Gbps) port (USB Type-C®).** This Universal Serial Bus (USB) port is for a USB 3.2 Gen 2 Type-C® device.
10. **USB 3.2 Gen 1 (up to 5Gbps) port.** This 9-pin Universal Serial Bus (USB) port is for a USB 3.2 Gen 1 device.



- USB 3.2 Gen 1 devices can only be used for data storage.
 - We strongly recommend that you connect USB 3.2 Gen 1 devices to USB 3.2 Gen 1 ports for faster and better performance from your USB 3.2 Gen 1 devices.
 - Due to the design of the Intel® 300 series chipset, all USB devices connected to the USB 2.0 and USB 3.2 Gen 1 ports are controlled by the xHCI controller. Some legacy USB devices must update their firmware for better compatibility.
-

11. **USB 3.2 Gen 2 (up to 10Gbps) ports (teal blue, Type-A).** These 9-pin Universal Serial Bus (USB) ports are for USB 3.2 Gen 2 devices.
12. **Line Out port (lime).** This port connects to a headphone or a speaker. In the 4 and 5.1 channel configurations, the function of this port becomes Front Speaker Out.

2.6.2 Internal connectors

1. LCD panel monitor switch header (2-pin PANEL_SW)

This 2-pin header is for connecting a monitor switch that can turn off the LCD panel display backlight.

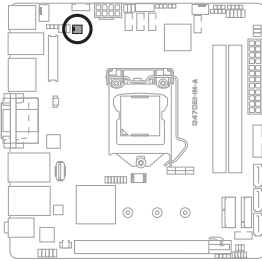

PANEL_SW



2. USB 3.2 Gen 1 connector (20-1 pin U32G1_78)

Connect a USB 3.2 Gen 1 module to this connector for additional USB 3.2 Gen 1 front or rear panel ports. This connector complies with USB 3.2 Gen 1 specifications and provides faster data transfer speeds of up to 5 Gbps, faster charging time for USB-chargeable devices, optimized power efficiency, and backward compatibility with USB 2.0.

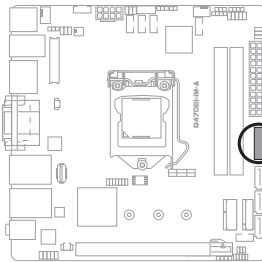

U32G1_78

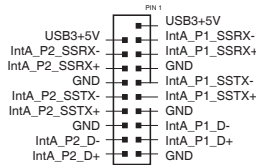

Connector type

BOX HD 2x10p, K20, 2.0mm pitch

3. USB3.2 Gen 1 port (U32G1_6)

This Universal Serial Bus (USB) port is for USB 3.2 Gen 1 devices.

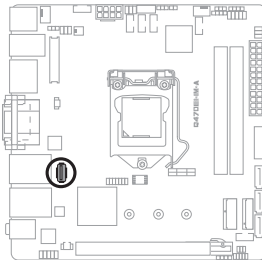

U32G1_6



4. USB 2.0 connector (10-1 pin USB213)

This connector is for an USB 2.0 port. Connect the USB cable to this connector. This USB connector complies with USB 2.0 specification that supports up to 480 Mbps connection speed.

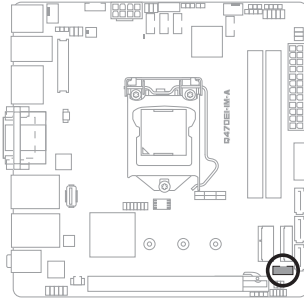

USB_213

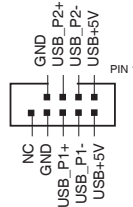

Connector type Header 2x5p, K9, 2.0mm pitch



CAUTION! Never connect a 1394 cable to the USB connector. Doing so will damage the motherboard.



NOTE: The USB cable is purchased separately.

5. General purpose input/output connector (10-pin GPIO_CON)

This connector is for a general purpose input/output module which allows you to customize the digital signal input/output.

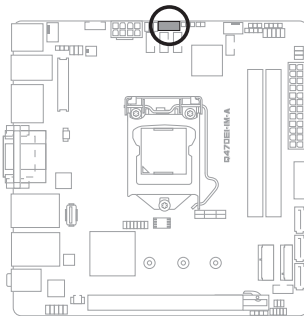

GPIO_CON

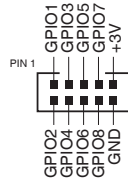

Connector type WAFER HD 2x5p, 2.0mm pitch, S/T

6. CPU and chassis fan connectors (4-pin CPU_FAN, 4-pin CHA_FAN)

Connect the fan cables to the fan connectors on the motherboard, ensuring that the black wire of each cable matches the ground pin of the connector.

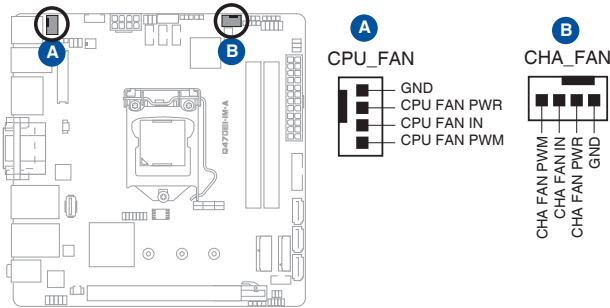

Connector type WAFER HD 4p, 2.54mm pitch, S/T



CAUTION! Do not forget to connect the fan cables to the fan connectors. Insufficient air flow inside the system may damage the motherboard components. These are not jumpers! Do not place jumper caps on the fan connectors!

7. TPM connector (14-1 pin TPM)

This connector supports a Trusted Platform Module (TPM) system with a Serial Peripheral Interface (SPI), allowing you to securely store keys, digital certificates, passwords and data. A TPM system also enhances network security, protects digital identities, and ensures platform integrity.

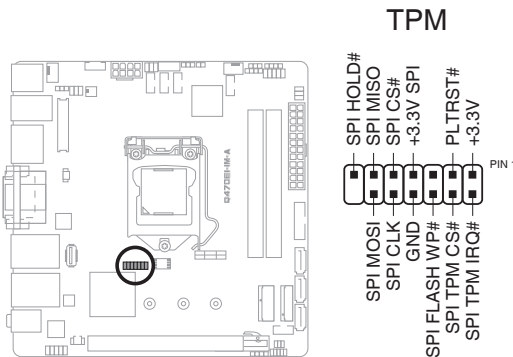

Connector type Header 2x7p, K14, 2.0mm pitch

8. Front panel system panel connector (10-1 pin F_PANEL)

This connector supports several chassis-mounted functions.

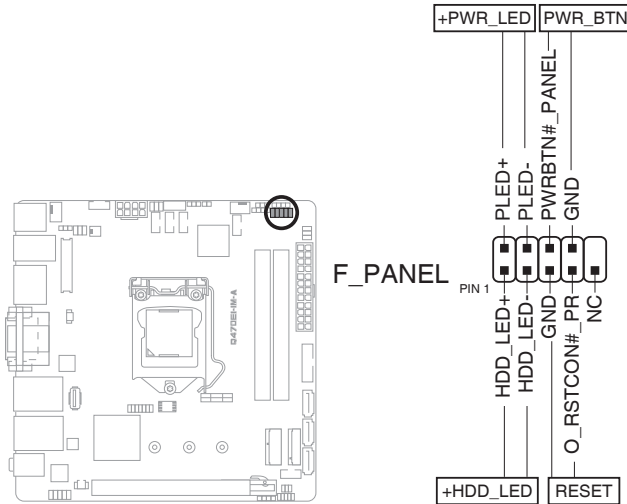

Connector type Header 2x5p, K10, 2.54mm pitch

- **System power LED (2-pin +PWR_LED)**
This 2-pin connector is for the system power LED. Connect the chassis power LED cable to this connector. The system power LED lights up when you turn on the system power, and blinks when the system is in sleep mode.
- **Hard disk drive activity LED (2-pin +HDD_LED)**
This 2-pin connector is for the HDD Activity LED. Connect the HDD Activity LED cable to this connector. The IDE LED lights up or flashes when data is read from or written to the HDD.
- **ATX power button/soft-off button (2-pin PWR_BTN)**
This 2-pin connector is for the system power button.
- **Reset button (2-pin RESET)**
This 2-pin connector is for the chassis-mounted reset button for system reboot without turning off the system power.

9. Serial ATA 6.0Gb/s connectors (7-pin SATA6G_1/2/3)

These connectors connect to Serial ATA 6.0 Gb/s hard disk drives or an optical drive via Serial ATA 6.0 Gb/s signal cables.

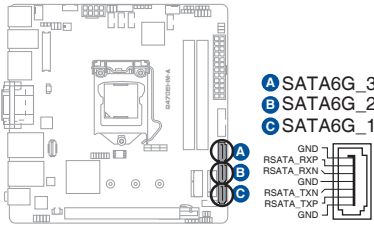

Connector type WAFER HD 7p, 1.27mm pitch

10. LVDS/EPD Signal Connector (40-pin LVDS_EPD)

This header is for an LCD monitor that supports Low Voltage Differential Signaling (LVDS) interface or an internal embedded DisplayPort (eDP) connection.

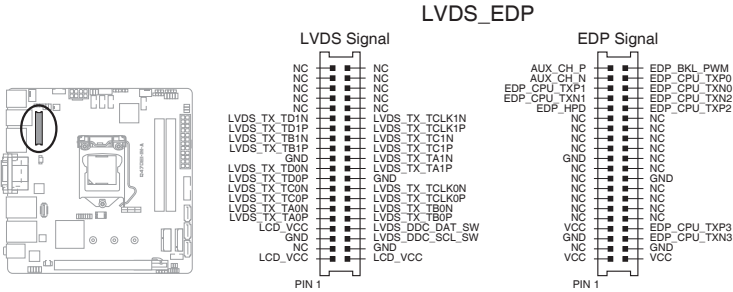

Connector type WAFER HD 2x20p, 1.25mm pitch

11. Speaker connector (4-pin SPEAKER)

The 4-pin connector is for the chassis-mounted system warning speaker. The speaker allows you to hear system beeps and warnings.

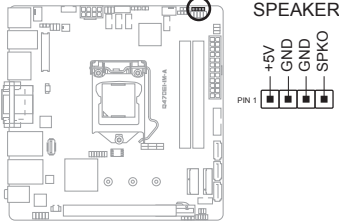

Connector type HEADER 1x4p, 2.54mm pitch, S/T

12. RTC Battery connector (2-pin BATTERY)

This connector is for the lithium CMOS battery.

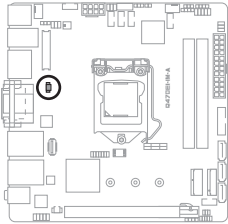

BATTERY



13. M.2 socket 3

This socket allows you to install an M.2 SSD module.

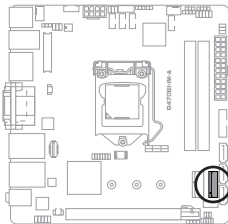

M.2(SOCKET3)



NOTES:

- The M.2 SSD module is purchased separately.
- This socket supports M Key and 2242/2260/2280 storage devices.

14. M.2 Wi-Fi

This socket connects to an M.2 Wi-Fi device.

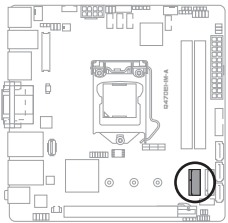

M.2(WIFI)

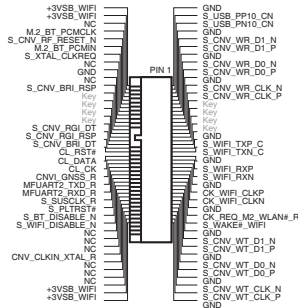

NOTE: The M.2 Wi-Fi module is purchased separately.

15. LPC Debug header (10-1 pin LPC_DEBUG)

This header allows connection to a LPC debug card.

LPC_DEBUG

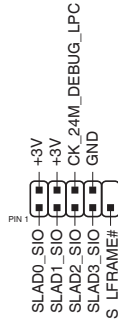
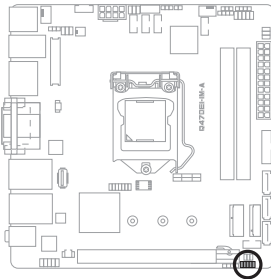

Connector type HEADER 2x5p, K10, 2.0mm pitch



IMPORTANT!

- Scan the QR code to view the meaning of each debug code.
- Debug codes are only available for ASUS LPC debug card.
- Contact your region sales representative for LPC debug header ordering.

16. I²C connector (6-pin I2C)

The I²C (Inter-Integrated Circuit) connector allows you to connect an I²C compatible IoT security module.

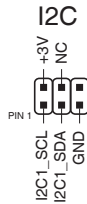
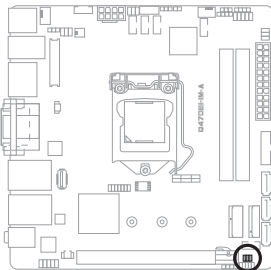

Connector type Header 2x3p, K6, 2.0mm pitch

17. Serial port connectors (10-1 pin COM2, COM3, COM4, COM5)

These connectors are for serial (COM) ports. Connect the serial port cables to these connectors, then install the module to a slot opening at the back of the system chassis.

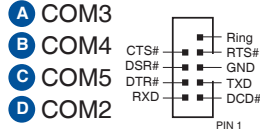
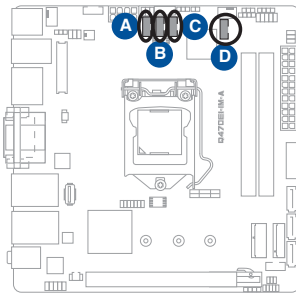

Connector type BOX header 2x5p, K10, 2.0mm pitch



NOTE: The serial port cables are purchased separately.

18. Flat panel display brightness connector (5-pin LCD_BLK_PANEL)

This connector is for the LCD panel brightness controls.

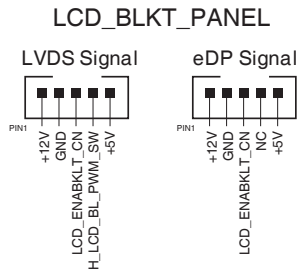
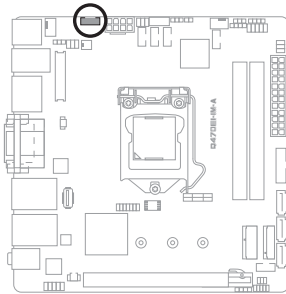

Connector type WAFER 6p, 2.0mm pitch

19. Digital audio connector (4-1 pin SPDIF_OUT)

This connector is for an additional Sony/Philips Digital Interface (S/PDIF) port. Connect the S/PDIF Out module cable to this connector, then install the module to a slot opening at the back of the system chassis.

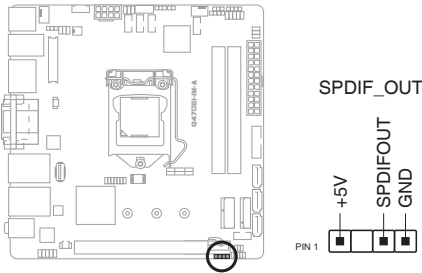

Connector type	HEADER 1x4p, K2, 2.54mm pitch
-----------------------	-------------------------------



NOTE: The SPDIF Out module is purchased separately.

20. Front panel audio connector (10-1 pin AAFP)

This connector is for a chassis-mounted front panel audio I/O module that supports HD Audio standard. Connect one end of the front panel audio I/O module cable to this connector.

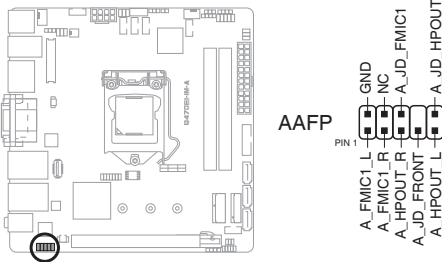

Connector type	HEADER 2x5p, K8, 2.54mm pitch
-----------------------	-------------------------------



IMPORTANT!

- We recommend that you connect a high-definition front panel audio module to this connector to avail of the motherboard's high-definition audio capability.
- If you want to connect a high-definition front panel audio module to this connector, set the HD Audio Controller item in the BIOS Setup to [Enabled].

21. ATX power connectors (24-pin EATXPWR, 8-pin EATX12V)

Correctly orient the ATX power supply plugs into these connectors and push down firmly until the connectors completely fit.

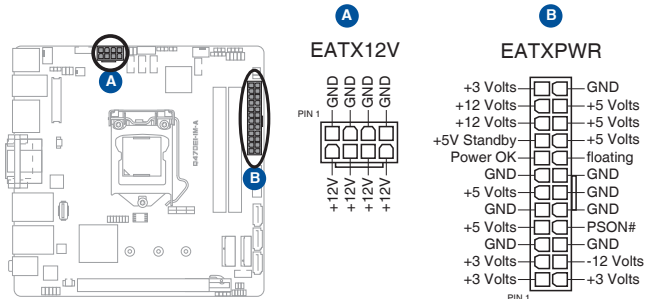

DC Mode EATXPWR

Pins	Signal	Pins	Signal
1	+3.3V out	13	+3.3V out
2	+3.3V out	14	NC
3	GND	15	GND
4	+5V out	16	PSOEN#
5	GND	17	GND
6	+5V out	18	GND
7	GND	19	GND
8	NC	20	+12V out
9	NC	21	+5V out
10	+12V in	22	+5V out
11	+12V in	23	+5V out
12	+3.3V out	24	GND

DC Mode EATX12V

Pins	Signal	Pins	Signal
1	GND	5	+12V in
2	GND	6	+12V in
3	GND	7	+12V in
4	GND	8	+12V in

Chapter 3

BIOS setup



Scan the QR code to view the BIOS update guide.



3.1 BIOS Setup program

Use the BIOS Setup program to update the BIOS or configure its parameters. The BIOS screens include navigation keys and brief online help to guide you in using the BIOS Setup program.

Entering BIOS Setup at startup

To enter BIOS Setup at startup:

Press <Delete> or <F2> during the Power-On Self Test (POST). If you do not press <Delete> or <F2>, POST continues with its routines.

Entering BIOS Setup after POST

To enter BIOS Setup after POST:

- Press <Ctrl>+<Alt>+ simultaneously.
- Press the reset button on the system chassis.
- Press the power button to turn the system off then back on. Do this option only if you failed to enter BIOS Setup using the first two options.



NOTE: Using the power button, reset button, or the <Ctrl>+<Alt>+ keys to reboot a running operating system can cause damage to your data or system. Always shut down the system properly from the operating system.



IMPORTANT!

- Visit the ASUS website at www.asus.com to download the latest BIOS file for this motherboard.
- The default BIOS settings for this motherboard apply to most working conditions and ensures optimal performance. If the system becomes unstable after changing any BIOS settings, load the default settings to regain system stability. Select the option **Restore Defaults** under the Exit menu or press hotkey <F3>.
- The BIOS Setup screens shown in this section are for reference purposes only, and may not exactly match what you see on your screen.

BIOS menu screen

The menu bar on top of the screen has the following main items:

Main	For changing the basic system configuration.
Advanced	For changing the advanced system settings.
Hardware Monitor	For displaying the system temperatures, fan and power status, and changing smart fan settings.
Security	For configuring the system security settings.
Boot	For changing the system boot configuration.
Exit	For selecting the save options and default options.

To select an item on the menu bar, press the right or left arrow key on the keyboard until the desired item is highlighted.

3.2 Main menu

The Main menu provides you with an overview of the basic system information, and allows you to set the system date and the system time.

3.2.1 System Date [Day MM/DD/YYYY]

Allows you to set the system date.

3.2.2 System Time [HH:MM:SS]

Allows you to set the system time.

3.3 Advanced menu

The Advanced menu items allow you to change the settings for the CPU and other system devices.



Be cautious when changing the settings of the Advanced menu items. Incorrect field values can cause the system to malfunction.

3.3.1 LVDS Configuration

Switch to LVDS

Configuration options: [Disable] [Enable]

All-in-One Chassis

Allows you to select All-in-One (AiO) Chassis (if applicable) for simplified AiO configuration. Configuration options: [None] [1920*1080 LVDS1] [1920*1080 LVDS2] [1920*1080 LVDS3] [1600*900 LVDS4]



- Be cautious when selecting AiO chassis. Incorrect selection of AiO chassis can cause incorrect operation or potential damage to AiO chassis hardware.
- The following items appear only when you set **All-in-One Chassis** to **[None]**.

EDID Data Source

Configuration options: [Pre-Defined] [Flat Panel Display]



The following item appears when you set **EDID Data Source** to **[Pre-Defined]**.

LFP Panel Type

Allows you to select LFP panel used by Internal Graphics Device.

Configuration options: [VBIOS Default] [640x480] [800x600] [1024x768] [1280x1024] [1400x1050 LVDS1] [1400x1050 LVDS2] [1600x1200] [1366x768] [1680x1050] [1920x1200] [1440x900] [1600x900] [1024x768] [1280x800] [1920x1080] [2048x1536]

Backlight Control

Configuration options: [PWM Inverted] [PWM Normal]

Channel Select

Configuration options: [Dual Channel] [Single Channel]

Mode Select

Configuration options: [8bit Mode(JEIDA)] [8bit Mode(VESA)] [6bit Mode(VESA and JEIDA)]

Panel Power Sequence Control

Configuration options: [Enable] [Disabled]



The following items appear when you set **Panel Power Sequence Control** to **[Enable]**.

Panel_Vcc ON to Video_Data ON (T8)

Configuration options: [10 ms] [20 ms] [30 ms] [40 ms]

Video_Data ON to BKLT_PWM ON (T9)

Configuration options: [100 ms] [200 ms] [250 ms] [300 ms]

BKLT_PWM ON to BKLT_Enable ON (T10)

Configuration options: [10 ms] [15 ms] [20 ms] [25 ms]

BKLT_Enable OFF to BKLT_PWM OFF (T11)

Configuration options: [5 ms] [10 ms] [15 ms] [20 ms]

BKLT_PWM OFF to Video_Data OFF (T12)

Configuration options: [100 ms] [200 ms] [250 ms] [300 ms]

Video_Data OFF to Panel_Vcc OFF (T13)

Configuration options: [10 ms] [20 ms] [30 ms] [40 ms]

Min Panel_Vcc OFF Time (T15)

Configuration options: [600 ms] [700 ms] [800 ms] [1000 ms]

LVDS Spread Spectrum Control

Allows you to configure LVDS spread spectrum clocking. Configuration options: [Disabled] [+/- 0.5%% Center Spread] [+/- 1%% Center Spread]

3.3.2 PCH-FW Configuration

This item allows you to configure Management Engine Technology parameters.

TPM Device Selection

Allows you to select TPM device.

[PTT] Enables PTT in SkuMgr.

[dTPM] Disables PTT in SkuMgr.



When PTT is disabled, all data saved on it will be lost.

3.3.3 Trusted Computing

Security Device Support

Allows you to enable or disable BIOS support for security device.

Configuration options: [Disabled] [Enabled]



The following items appear when a TPM device is installed on your motherboard.

SHA-1 PCR Bank

Configuration options: [Disabled] [Enabled]

SHA256 PCR Bank

Configuration options: [Disabled] [Enabled]

SHA384 PCR Bank

Configuration options: [Disabled] [Enabled]

Pending operation

Allows you to schedule an operation for security device.

Configuration options: [None] [TPM Clear]



Your computer will reboot during restart in order to change the state of security device.

Platform Hierarchy

Configuration options: [Disabled] [Enabled]

Storage Hierarchy

Configuration options: [Disabled] [Enabled]

Endorsement Hierarchy

Configuration options: [Disabled] [Enabled]

TPM 2.0 UEFI Spec Version

Allows you to select the TCG2 Spec Version support.

Configuration options: [TCG_1_2] [TCG_2]

[TCG_1_2] Support the compatible mode for Win8/Win10.

[TCG_2] Support new TCG2 protocol and event format for Win10 or later.

Physical Presence Spec Version

Allows you to select to tell O.S. to support PPI Spec Version 1.2 or 1.3.

Configuration options: [1.2] [1.3]



Some HCK tests might not support 1.3.

PH Randomization

Allows you to enable or disables Platform Hierarchy randomization. Configuration options: [Disabled] [Enabled]



Do not enable this question in production platforms. This is for development testing. OVERRIDE ChangePlatformAuth ELINK for production platforms supports TXT.

3.3.4 CPU Configuration

The items in this menu show CPU-related information the BIOS automatically detects.

CPU Run Control

Configuration options: [Disabled] [Enabled] [No Change]

Software Guard Extensions (SGX)

Configuration options: [Disabled] [Enabled] [Software Controlled]

Intel (VMX) Virtualization Technology

This item, when set to [enabled], will allow a VMM to utilize the additional hardware capacities provided by Vanderpool Technology.

Configuration options: [Disabled] [Enabled]

Hyper-Threading

Configuration options: [Disabled] [Enabled]

VT-d

Configuration options: [Disabled] [Enabled]

CPU - Power Management Control

This item allows you to manage and configure the CPU's power.

Intel® SpeedStep™

Allows your system to support more than two frequency ranges.

Configuration options: [Disabled] [Enabled]

Intel® Speed Shift Technology

Allows you to enable or disable Intel® Speed Shift Technology support. When enabled, CPPC v2 interface allows hardware controlled P-state. Configuration options: [Disabled] [Enabled]



The following item appears only when **Intel® SpeedStep** or **Intel® Speed Shift** is available and enabled.

Turbo Mode

Configuration options: [Disabled] [Enabled]

C states

Allows you to enable or disable CPU Power Management. Configuration options: [Disabled] [Enabled]



The following item appears only when you set **C states** to **[Enabled]**.

Enhanced C-states

Allows you to enable or disable C1E. CPU will switch to minimum speed when all cores enter C-state. Configuration options: [Disabled] [Enabled]

Package C State Limit

Set the maximum package C state limit. Configuration options: [C0/C1] [C2] [C3] [C6] [C7] [C7S] [C8] [C9] [C10] [Cpu Default] [Auto]

[Cpu Default] Leaves to factory default value.

[Auto] Initializes to deepest available Package C State Limit.

3.3.5 Graphics Configuration

This item allows you to select a primary display from IGFX and PEG graphical devices.

Primary Display

Allows you to select which of the IGFX/PEG Graphics devices should be the primary display or select SG for switchable Gfx.

Configuration options: [Auto] [IGFX] [PEG]

Internal Graphics

Configuration options: [Auto] [Disabled] [Enabled]

[Auto] Keeps IGFX enabled base on the setup options.

[Disabled] Disables internal graphics.

[Enabled] Enables internal graphics.

3.3.6 PCI Express Configuration

This item allows you to configure PCI Express settings.

HYPER_PClEX16

Configuration options: [PCIe x16 mode] [PCIe x8/x8 mode] [PCIe x8/x4/x4 mode]

PCIe x16/x8 Slot

Allows you to configure the PEG Port settings.

PEG 0:1:0

Enable Root Port

Allows you to enable or disable the Root Port.
Configuration options: [Disabled] [Enabled] [Auto]

Max Link Speed

Allows you to configure PEG 0:1:0 Max Speed.
Configuration options: [Auto] [Gen1] [Gen2] [Gen3]

Max Link Width

Allows you to force PEG link to restrain to X1/2/4/8.
Configuration options: [Auto] [Force X1] [Force X2] [Force X4] [Force X8]

ASPM

Allows you to control ASPM support for the PEG 0, and this has no effect if PGE is not the currently active device.
Configuration options: [Disabled] [Auto] [ASPM L0s] [ASPM L1] [ASPM L0sL1]

PEG 0:1:1

Enable Root Port

Allows you to enable or disable the Root Port.
Configuration options: [Disabled] [Enabled] [Auto]

Max Link Speed

Allows you to configure PEG 0:1:1 Max Speed.
Configuration options: [Auto] [Gen1] [Gen2] [Gen3]

Max Link Width

Allows you to force PEG link to restrain to X1/2/4.
Configuration options: [Auto] [Force X1] [Force X2] [Force X4]

ASPM

Allows you to control ASPM support for the PEG 1, and this has no effect if PGE is not the currently active device.
Configuration options: [Disabled] [Auto] [ASPM L0s] [ASPM L1] [ASPM L0sL1]

PEG 0:1:2

Enable Root Port

Allows you to enable or disable the Root Port.
Configuration options: [Disabled] [Enabled] [Auto]

Max Link Speed

Allows you to configure PEG 0:1:2 Max Speed.
Configuration options: [Auto] [Gen1] [Gen2] [Gen3]

Max Link Width

Allows you to force PEG link to restrain to X1/2.
Configuration options: [Auto] [Force X1] [Force X2]

ASPM

This item allows you to control ASPM support for the PEG 2, and this has no effect if PGE is not the currently active device.
Configuration options: [Disabled] [Auto] [ASPM L0s] [ASPM L1] [ASPM L0sL1]

3.3.7 AMT Configuration

This item allows you to configure Intel® Active Management Technology parameters.

AMT BIOS Features

Allows you to enable or disable AMT BIOS Features. When set to [Disabled], MEBx Setup will be inaccessible.

Configuration options: [Disabled] [Enabled]



This item does not disable Manageability Features in FW.

USB Provisioning of AMT

Allows you to enable or disable AMT USB Provisioning.

Configuration options: [Disabled] [Enabled]

End Of Post Message

Allows you to enable or disable End of Post message sent to ME.

Configuration options: [Disabled] [Enabled]

Secure Erase Configuration

Secure Erase mode

Allows you to change Secure Erase module behavior.

Configuration options: [Simulated] [Real]

[Simulated] Performs SE flow without erasing SSD.

[Real] Erases SSD.

Force Secure Erase

Allows you to force Secure Erase on next boot.

Configuration options: [Disabled] [Enabled]

OEM Flags Settings

Allows you to configure OEM Flags.

MEBx Selection Screen

Allows you to enable MEBx selection screen by pressing 1 to enter ME

Configure Screen or pressing 2 to initiate a remote connection.

Configuration options: [Disabled] [Enabled]



Network Access must be activated from MEBx Setup for this screen to be displayed.

Unconfigure ME

Allows you to unconfigure ME by resetting the MEBx password to default.

Configuration options: [Disabled] [Enabled]

3.3.8 CSM Configuration

CSM Support

Allows you to enable or disable CSM (Compatibility Support Module) Support.

Configuration options: [Disabled] [Enabled]



The following items appear only when you set **CSM Support** to **[Enabled]**.

GateA20 Active

Configuration options: [Upon Request] [Always]

[Upon Request] GA20 can be disabled using BIOS services.

[Always] Do not allow disabling GA20, which functions when any RT code is executed above 1MB.

Network

Allows you to control the execution of UEFI and Legacy Network OpROM.

Configuration options: [Do not launch] [UEFI] [Legacy]

Storage

Allows you to control the execution of UEFI and Legacy Storage OpROM.

Configuration options: [Do not launch] [UEFI] [Legacy]

Video

Allows you to control the execution of UEFI and Legacy Video OpROM.

Configuration options: [Do not launch] [UEFI] [Legacy]

Other PCI devices

Allows you to determine OpROM execution policy for devices other than Network, Storage, or Video.

Configuration options: [Do not launch] [UEFI] [Legacy]

3.3.9 Super IO Configuration

Serial Port 1 Configuration

This item allows you to set parameters of Serial Port 1 (COMA).

Serial Port

Allows you to enable or disable the serial port (COM).

Configuration options: [Disabled] [Enabled]

COM1 Control

Allows you to select COM1 mode.

Configuration options: [RS232] [RS422] [RS485]

Serial Port 2 Configuration

This item allows you to set parameters of Serial Port 2 (COMB).

Serial Port

Allows you to enable or disable the serial port (COM).

Configuration options: [Disabled] [Enabled]

COM2 Control

Allows you to select COM2 mode.

Configuration options: [RS232] [RS422] [RS485]

Serial Port 3 Configuration

This item allows you to set parameters of Serial Port 3 (COMC).

Serial Port

Allows you to enable or disable the serial port (COM). Configuration options:
[Disabled] [Enabled]

Serial Port 4 Configuration

This item allows you to set parameters of Serial Port 4 (COMD).

Serial Port

Allows you to enable or disable the serial port (COM). Configuration options:
[Disabled] [Enabled]

Serial Port 5 Configuration

This item allows you to set parameters of Serial Port 5 (COME).

Serial Port

Allows you to enable or disable the serial port (COM). Configuration options:
[Disabled] [Enabled]

3.3.10 Serial Console Redirection

COM1(~5)

Console Redirection

Allows you enable or disable the console redirection feature.
Configuration options: [Enabled] [Disabled]



The following item is accessible when you set **Console Redirection** to **[Enabled]**.

Console Redirection Settings

The settings specify how the host computer and the remote computer (which the user is using) will exchange data. Both computers should have the same or compatible settings.

Terminal Type

Configuration options: [VT100] [VT100+] [VT-UTF8] [ANSI]

[VT100] ASCII char set.

[VT100+] Extends VT100 to support color, function keys, etc.

[VT-UTF8] Uses UTF8 encoding to map Unicode chars onto 1 or more bytes.

[ANSI] Extended ASCII char set.

Bits per second

Allows you to select serial port transmission speed. The speed must be matched on the other side. Long or noisy lines may require lower speeds.
Configuration options: [9600] [19200] [38400] [57600] [115200]

Data Bits

Configuration options: [7] [8]

Parity

A parity bit can be sent with the data bits to detect some transmission errors. Configuration options: [None] [Even] [Odd] [Mark] [Space]

[None]	Disables parity check.
[Even]	Parity bit is 0 if the num of 1's in the data bits is even.
[Odd]	Parity bit is 0 if the num of 1's in the data bits is odd.
[Mark]	Parity bit is always 1.
[Space]	Parity bit is always 0.



Mark and Space Parity do not allow for error detection.

Stop Bits

Stop bits indicate the end of a serial data packet. The standard setting is 1 stop bit. Communication with slow devices may require more than 1 stop bit. Configuration options: [1] [2]

Flow Control

Flow control can prevent data loss from buffer overflow. When sending data, if the receiving buffers are full, a “stop” signal can be sent to stop the data flow. Once the buffers are empty, a “start” signal can be sent to re-start the flow. Hardware flow control uses two wires to send start/stop signals. Configuration options: [None] [Hardware RTS/CTS]

VT-UTF8 Combo Key Support

Allows you to enable or disable VT-UTF8 Combination Key Support for ANSI/VT100 terminals. Configuration options: [Disabled] [Enabled]

Recorder Mode

With this mode enabled only text will be sent. This is to capture Terminal data. Configuration options: [Disabled] [Enabled]

Resolution 100x31

Allows you to enable or disable extended terminal resolution. Configuration options: [Disabled] [Enabled]

Putty KeyPad

Allows you to select FunctionKey and KeyPad on Putty. Configuration options: [VT100] [LINUX] [XTERMR6] [SCO] [ESCN] [VT400]

COM6(Pci Bus0,Dev0,Func0) (Disabled)

Legacy Console Redirection Settings

Redirection COM Port

Allows you to select a COM port to display redirection of Legacy OS and Legacy OPROM Messages. Configuration options: [COM1] [COM2] [COM3] [COM4] [COM5] [COM6(Pci Bus0,Dev0,Func0) (Disabled)]

Resolution

This allows you to set the number of rows and columns supported on the Legacy OS. Configuration options: [80x24] [80x25]

Redirect After POST

Configuration options: [Always Enable] [BootLoader]

[Always Enable] Legacy Console Redirection is enabled for Legacy OS.

[BootLoader] Legacy Console Redirection is disabled before booting to Legacy OS.

3.3.11 SATA And RST Configuration

This item allows you to configure SATA device options settings.

SATA Controller(s)

Allows you to enable or disable the onboard SATA device.

Configuration options: [Disabled] [Enabled]



The following item appears only when you set **SATA Controller(s)** to **[Enabled]**.

SATA Mode Selection

Allows you to determine how SATA controller(s) operate. Configuration options: [AHCI] [Intel RST Premium With Intel Optane System Acceleration]

[AHCI] Set to [AHCI] when you want the SATA hard disk drives to use the AHCI (Advanced Host Controller Interface). The AHCI allows the onboard storage driver to enable advanced Serial ATA features that increases storage performance on random workloads by allowing the drive to internally optimize the order of commands.

[Intel RST Premium With Intel Optane System Acceleration] Set to [Intel RST Premium With Intel Optane System Acceleration] when you want to create a RAID configuration from the SATA hard disk drives.



The following items appear only when you set **SATA Mode Selection** to **[Intel RST Premium With Intel Optane System Acceleration]**.

Sata Interrupt Selection

Allows you to select which interrupt will be available to the operating system. This option only takes effect if SATA controller is in RAID mode.

Configuration options: [Msi] [Legacy]

RAID Device ID

Allows you to choose RAID device ID.

Configuration options: [Client] [Alternate]

Aggressive LPM Support

Allows you to enable PCH to aggressively enter link power state.

Configuration options: [Disabled] [Enabled]

Serial ATA Port 1(~3)

Port 1(~3)

Allows you to enable or disable SATA Port.

Configuration options: [Disabled] [Enabled]

Hot Plug

Allows you to designate this port as Hot Pluggable.

Configuration options: [Disabled] [Enabled]

M.2 SATA(M-Key)

Port 4

Allows you to enable or disable SATA Port.

Configuration options: [Disabled] [Enabled]

3.3.12 Network Stack Configuration

Network Stack

This item allows user to disable or enable the UEFI Network Stack.

Configuration options: [Disabled] [Enabled]



The following items appear only when you set **Network Stack** to **[Enabled]**.

IPv4 PXE Support

Allows you to enable or disable IPv4 PXE boot support. If disabled, IPv4 PXE boot support will be unavailable. Configuration options: [Disabled] [Enabled]

IPv6 PXE Support

Allows you to enable or disable IPv6 PXE boot support. If disabled, IPv6 PXE boot support will be unavailable. Configuration options: [Disabled] [Enabled]

PXE boot wait time

Use either +/- or numeric keys to set the value for wait time (in seconds) to press ESC key to abort the PXE boot.

Media detect count

Use either +/- or numeric keys to set the value for number of times the presence of media will be checked.

3.3.13 USB Configuration

Legacy USB Support

Configuration options: [Enabled] [Disabled] [Auto]

[Enabled] Enables Legacy USB support.

[Disabled] Keeps USB devices available only for EFI applications.

[Auto] Allows the system to detect the presence of USB devices at startup. If any USB device(s) is detected, the USB controller legacy mode is enabled. If none is detected, the legacy USB support is disabled.

XHCI Hand-off

This item functions as a workaround for OSES without XHCI hand-off support. The XHCI ownership change should be claimed by XHCI driver.

Configuration options: [Enabled] [Disabled]

USB Mass Storage Driver Support

Allows you to enable or disable USB Mass Storage Driver Support.

Configuration options: [Disabled] [Enabled]

U32G1_1(~3)

Allows you to enable or disable USB port. Once set to [Disabled], any USB devices plugged into the connector will not be detected by BIOS or OS.

Configuration options: [Disabled] [Enabled]

U32G2_4(~5)

Allows you to enable or disable USB port. Once set to [Disabled], any USB devices plugged into the connector will not be detected by BIOS or OS.

Configuration options: [Disabled] [Enabled]

U32G1_6(~8)

Allows you to enable or disable USB port. Once set to [Disabled], any USB devices plugged into the connector will not be detected by BIOS or OS.

Configuration options: [Disabled] [Enabled]

USB_2, USB_9(~13)

Allows you to enable or disable USB port. Once set to [Disabled], any USB devices plugged into the connector will not be detected by BIOS or OS.

Configuration options: [Disabled] [Enabled]

3.3.14 NVMe Configuration

The NVMe Configuration menu displays the NVMe controller and drive information of the devices connected and allows you to configure NVMe device options settings.

3.3.15 Onboard Devices Configuration

HD Audio Controller

Allows you to control detection of the HD-Audio device.

Configuration options: [Enabled] [Disabled]

[Enabled] Enables the HD Audio Device unconditionally.

[Disabled] Disables the HD Audio Device unconditionally.

LAN1 I219

Configuration options: [Disabled] [Enabled]

Intel LAN1 OPROM

Allows you to launch Intel PXE OPROM. Configuration options: [Disabled] [Enabled]

LAN2 I210

Configuration options: [Disabled] [Enabled]

Intel LAN2 OPROM

Allows you to launch Intel PXE OPROM. Configuration options: [Disabled] [Enabled]

I2C0 Controller

Allows you to enable or disable Serial IO Controller.

Configuration options: [Disabled] [Enabled]

3.3.16 EZ-Flash

This item allows you to enter EZ-Flash mode. After you press <Enter>, a confirmation message appears. Use the left/right arrow key to select between [Yes] or [No], then press <Enter> to confirm your choice.

3.3.17 APM Configuration

This item allows you to configure APM (Advanced Power Management) settings.

ErP Ready

Allows BIOS to switch off some power at S5 to get the system ready for ErP requirement. When set to [Enabled], all other PME options will be switched off.

Configuration options: [Disabled] [Enabled]

Restore AC Power Loss

Allows you to select AC power state when power is re-applied after a power failure.

Configuration options: [S5 State] [S0 State]

Power On By PCIE

Allows you to enable or disable the Wake-on-LAN function of the onboard LAN controller or other installed PCIe LAN cards.

Configuration options: [Disabled] [Enabled]

Power On By Ring

Configuration options: [Disabled] [Enabled]

Power On By RTC

Configuration options: [Disabled] [Enabled]



The following items appear when you set **Power On By RTC** to [Enabled].

RTC Alarm Date (Days)

Allows you to set the value for number of days of RTC Alarm Date. Value 0 represents "Every Day".

Wake up hour

Allows you to enter a natural number within 0-23 for hour. For example, enter 3 for 3:00 am and 15 for 3:00 pm.

Wake up minute

Allows you to enter a natural number within 0-59 for minute.

Wake up second

Allows you to enter a natural number within 0-59 for second.

3.3.18 Watchdog Timer

Watchdog Support

Configuration options: [Disabled] [Enabled]



The following items appear when you set **Watchdog Support** to **[Enable]**.

Watchdog Count mode

Allows you to select Watchdog Timer I count mode.

Configuration options: [Second Mode] [Minute Mode]

Watchdog Timer

Allows you to set the Watchdog Timer I Time-out value.

3.3.19 Miscellaneous

DMI/OPI Configuration

DMI Link ASPM Control

Allows you to disable or control Active State Power Management on SA side of the DMI link. Configuration options: [Disabled] [L0s] [L1] [L0sL1]

PCI Express Configuration

DMI Link ASPM Control

Allows you to disable or control Active State Power Management on SA side of the DMI link. Configuration options: [Disabled] [L0s] [L1] [L0sL1] [Auto]

3.4 Hardware Monitor menu

The Monitor menu displays the system temperatures, fan and power status, and allows you to configure the smart fan.

3.4.1 Smart Fan Mode

Allows you to select the Smart Fan mode. Configuration options: [Disabled] [Normal] [Manual Mode]



The following items appear only when you set **Smart Fan Mode** to [Manual Mode].

3.4.2 Smart Fan Function

Chassis Fan Setting

Temperature 1(~4)

Allows you to set the value of temperature1(~4).

FD/RPM 1(~4)

Allows you to set the value of Fan Duty/PRM 1(~4) when temperature is T1(~4).

CPU Fan Setting

Temperature 1(~4)

Allows you to set the value of temperature1(~4).

FD/RPM 1(~4)

Allows you to set the value of Fan Duty/PRM 1(~4) when temperature is T1(~4).

3.5 Security menu

The Security menu allows a new password to be created or a current password to be changed. The menu also enables or disables the Secure Boot state and lets the user configure the System Mode state.

3.5.1 Administrator Password

If you have set an administrator password, we recommend that you enter the administrator password for accessing the system.

To set an administrator password:

1. Select the **Administrator Password** item and press <Enter>.
2. From the **Create New Password** box, key in a password, then press <Enter>.

To change an administrator password:

1. Select the **Administrator Password** item and press <Enter>.
2. From the **Enter Current Password** box, key in the current password, then press <Enter>.

3. From the **Create New Password box**, key in a new password, then press <Enter>.
4. Confirm the password when prompted.



To clear the administrator password, follow the same steps as in changing an administrator password, but press <Enter> when prompted to create/confirm the password.

3.5.2 User Password

If you have set a user password, you must enter the user password for accessing the system.

To set a user password:

1. Select the **User Password** item and press <Enter>.
2. From the **Create New Password box**, key in a password, then press <Enter>.
3. Confirm the password when prompted.

To change a user password:

1. Select the **User Password** item and press <Enter>.
2. From the **Enter Current Password box**, key in the current password, then press <Enter>.
3. From the **Create New Password box**, key in a new password, then press <Enter>.
4. Confirm the password when prompted.

To clear a user password:

1. Select the **Clear User Password** item and press <Enter>.
2. Select **Yes** from the Warning message window then press <Enter>.

3.5.3 Secure Boot

Secure Boot feature is active when Secure Boot is set to [Enabled], Platform Key (PK) is enrolled and the system is running in User mode. Changing the mode requires platform reset. Configuration options: [Disabled] [Enabled]

Secure Boot Mode

Allows you to select Secure Boot Mode. When set to [Custom], Secure Boot Policy variables can be configured by a physically present user without full authentication. Configuration options: [Standard] [Custom]

Key Management

Allows you to modify Secure Boot Policy variables without full authentication.

Platform Key (PK)

Configuration options: [Details] [Export] [Update] [Delete]

Key Exchange Keys / Authorized Signatures

Configuration options: [Details] [Export] [Update] [Append] [Delete]

Forbidden Signatures

Configuration options: [Update] [Append]

3.6 Boot menu

The items in the Boot menu allow you to change the system boot options.

Boot Configuration

CHASSIS INTRUDE

Allows you to enable or disable CHASSIS INTRUDE. Configuration options: [Disabled] [Enabled]

Setup Prompt Timeout

Allows you to set the number of seconds to wait for setup activation key. 65535(0xFFFF) means indefinite waiting.

Bootup NumLock State

Allows you to select the keyboard NumLock state. Configuration options: [On] [Off]

Quiet Boot

Configuration options: [Disabled] [Enabled]

Fast Boot

Allows you to enable or disable boot with initialization of a minimal set of devices required to launch active boot option. This has no effect for BBS boot options. Configuration options: [Disabled] [Enabled]

[Enabled] Select to accelerate the boot speed.

[Disabled] Select to go back to normal boot speed.

Boot mode select

Configuration options: [LEGACY] [UEFI]

FIXED BOOT ORDER Priorities

Boot Option #1(~10)

Allows you to set the system boot order. Configuration options: [Hard Disk] [NVME] [CD/DVD] [SD] [USB Hard Disk] [USB CD/DVD] [USB Key:UEFI: Generic-SD/MMC, Partition 1] [USB Floppy] [USB Lan] [Network] [Disabled]

UEFI USB Key Drive BBS Priorities

Boot Option #1

Allows you to set the system boot order.

Configuration options: [UEFI: Generic-SD/MMC, Partition 1] [Disable]

3.7 Exit menu

The items in the Exit menu allow you to save or discard your changes to the BIOS items.

Save Changes and Exit

Allows you to exit the system setup program after saving the changes.

Discard Changes and Exit

Allows you to exit the system setup program without saving the changes you made. When you select this option or if you press <Esc>, a confirmation window appears. Select **Yes** to discard changes and exit.

Save Changes and Reset

Allows you to reset the system setup after saving the changes.

Discard Changes and Reset

Allows you to reset the system setup without saving the changes you made.

Save Options

Save Changes

Allows you to save changes done so far to any of the setup options.

Discard Changes

Allows you to discard changes done so far to any of the setup options.

Restore Defaults

Allows you to restore or load default values for all the setup options.

Save as User Defaults

Allows you to save the changes done so far as User Defaults.

Restore User Defaults

Allows you to restore the User Defaults to all the setup options.

Boot Override

UEFI: Generic-SD/MMC, Partition 1

When you select this option, a confirmation window appears. Select **Yes** to save configuration and reset.

Appendix

Notices

FCC Compliance Information

Responsible Party: Asus Computer International

Address: 48720 Kato Rd., Fremont, CA 94538, USA

Phone / Fax No: (510)739-3777 / (510)608-4555

This device complies with part 15 of the FCC Rules. Operation is subject to the following two conditions: (1) This device may not cause harmful interference, and (2) this device must accept any interference received, including interference that may cause undesired operation.

This equipment has been tested and found to comply with the limits for a Class B digital device, pursuant to part 15 of the FCC Rules. These limits are designed to provide reasonable protection against harmful interference in a residential installation. This equipment generates, uses and can radiate radio frequency energy and, if not installed and used in accordance with the instructions, may cause harmful interference to radio communications. However, there is no guarantee that interference will not occur in a particular installation. If this equipment does cause harmful interference to radio or television reception, which can be determined by turning the equipment off and on, the user is encouraged to try to correct the interference by one or more of the following measures:

- Reorient or relocate the receiving antenna.
- Increase the separation between the equipment and receiver.
- Connect the equipment into an outlet on a circuit different from that to which the receiver is connected.
- Consult the dealer or an experienced radio/TV technician for help.

Compliance Statement of Innovation, Science and Economic Development Canada (ISED)

This device complies with Innovation, Science and Economic Development Canada licence exempt RSS standard(s). Operation is subject to the following two conditions: (1) this device may not cause interference, and (2) this device must accept any interference, including interference that may cause undesired operation of the device.

CAN ICES-003(B)/NMB-003(B)

Déclaration de conformité de Innovation, Sciences et Développement économique Canada (ISED)

Le présent appareil est conforme aux CNR d'Innovation, Sciences et Développement économique Canada applicables aux appareils radio exempts de licence. L'exploitation est autorisée aux deux conditions suivantes : (1) l'appareil ne doit pas produire de brouillage, et (2) l'utilisateur de l'appareil doit accepter tout brouillage radioélectrique subi, même si le brouillage est susceptible d'en compromettre le fonctionnement.

CAN ICES-003(B)/NMB-003(B)

VCCI: Japan Compliance Statement

Class B ITE

この装置は、クラスB情報技術装置です。この装置は、家庭環境で使用することを目的としていますが、この装置がラジオやテレビジョン受信機に近接して使用されると、受信障害を引き起こすことがあります。

取扱説明書に従って正しい取り扱いをして下さい。

VCCI-B

KC: Korea Warning Statement

B급 기기 (가정용 방송통신기자재)

이 기기는 가정용(B급) 전자파적합기기로서 주로 가정에서 사용하는 것을 목적으로 하며, 모든 지역에서 사용할 수 있습니다.

REACH

Complying with the REACH (Registration, Evaluation, Authorisation, and Restriction of Chemicals) regulatory framework, we published the chemical substances in our products at ASUS REACH website at <http://csr.asus.com/english/REACH.htm>.



DO NOT throw the motherboard in municipal waste. This product has been designed to enable proper reuse of parts and recycling. This symbol of the crossed out wheeled bin indicates that the product (electrical and electronic equipment) should not be placed in municipal waste. Check local regulations for disposal of electronic products.



DO NOT throw the mercury-containing button cell battery in municipal waste. This symbol of the crossed out wheeled bin indicates that the battery should not be placed in municipal waste.

ASUS Recycling/Takeback Services

ASUS recycling and takeback programs come from our commitment to the highest standards for protecting our environment. We believe in providing solutions for you to be able to responsibly recycle our products, batteries, other components as well as the packaging materials. Please go to <http://csr.asus.com/english/Takeback.htm> for detailed recycling information in different regions.

English ASUSTeK Computer Inc. hereby declares that this device is in compliance with the essential requirements and other relevant provisions of related Directives. Full text of EU declaration of conformity is available at: www.asus.com/support

Français ASUSTek Computer Inc. déclare par la présente que cet appareil est conforme aux critères essentiels et autres clauses pertinentes des directives concernées. La déclaration de conformité de l'UE peut être téléchargée à partir du site Internet suivant: www.asus.com/support

Deutsch ASUSTeK Computer Inc. erklärt hiermit, dass dieses Gerät mit den wesentlichen Anforderungen und anderen relevanten Bestimmungen der zugehörigen Richtlinien übereinstimmt. Der gesamte Text der EU-Konformitätserklärung ist verfügbar unter: www.asus.com/support

Italiano ASUSTeK Computer Inc. con la presente dichiara che questo dispositivo è conforme ai requisiti essenziali e alle altre disposizioni pertinenti con le direttive correlate. Il testo completo della dichiarazione di conformità UE è disponibile all'indirizzo: www.asus.com/support

Русский Компания ASUS заявляет, что это устройство соответствует основным требованиям и другим соответствующим условиям соответствующих директив. Подробную информацию, пожалуйста, смотрите на www.asus.com/support

Български С настоящото ASUSTeK Computer Inc. декларира, че това устройство е в съответствие със съществените изисквания и другите приложими постановления на свързаните директиви. Пълният текст на декларацията за съответствие на ЕС е достъпен на адрес: www.asus.com/support

Hrvatski ASUSTeK Computer Inc. ovim izjavljuje da je ovaj uređaj sukladan s bitnim zahtjevima i ostalim odgovarajućim odredbama vezanih direktiva. Cijeli tekst EU izjave o skladnosti dostupan je na: www.asus.com/support

Čeština Společnost ASUSTeK Computer Inc. tímto prohlašuje, že toto zařízení splňuje základní požadavky a další příslušná ustanovení souvisejících směrnic. Plné znění prohlášení o shodě EU je k dispozici na adrese: www.asus.com/support

Dansk ASUSTeK Computer Inc. erklærer hermed, at denne enhed er i overensstemmelse med hovedkravene og andre relevante bestemmelser i de relaterede direktiver. Hele EU-overensstemmelseserklæringen kan findes på: www.asus.com/support

Nederlands ASUSTeK Computer Inc. verklaart hierbij dat dit apparaat voldoet aan de essentiële vereisten en andere relevante bepalingen van de verwante richtlijnen. De volledige tekst van de EU-verklaring van conformiteit is beschikbaar op: www.asus.com/support

Eesti Käesolevaga kinnitab ASUSTeK Computer Inc, et see seade vastab asjakohaste direktiivide olulistele nõuetele ja teisteles asjassepuutuvatele sätetele. El vastavusdeklaratsiooni täielik tekst on saadaval järgmisel aadressil: www.asus.com/support

Suomi ASUSTeK Computer Inc. ilmoittaa täten, että tämä laite on asiaankuuluvien direktiivien olennaisten vaatimusten ja muiden tätä koskevien säädösten mukainen. EU-yhdenmukaisuusilmoituksen koko teksti on luettavissa osoitteessa: www.asus.com/support

Ελληνικά Με το παρόν, η ASUSTeK Computer Inc. δηλώνει ότι αυτή η συσκευή συμμορφώνεται με τις θεμελιώδεις απαιτήσεις και άλλες σχετικές διατάξεις των Οδηγιών της ΕΕ. Το πλήρες κείμενο της δήλωσης συμμόρφωσης είναι διαθέσιμο στη διεύθυνση: www.asus.com/support

Magyar Az ASUSTeK Computer Inc. ezennel kijelenti, hogy ez az eszköz megfelel a kapcsolódó irányelvek lényeges követelményeinek és egyéb vonatkozó rendelkezéseinek. Az EU megfélelősegi nyilatkozat teljes szövege innen letölthető: www.asus.com/support

Latviski ASUSTeK Computer Inc. ar šo paziņo, ka šī ierīce atbilst saistošo Direktīvu būtiskajām prasībām un citiem citiem saistošajiem nosacījumiem. Pilns ES atbilstības paziņojuma teksts pieejams šeit: www.asus.com/support

Lietuvių „ASUSTeK Computer Inc.“ šiuo tvirtina, kad šis įrenginys atitinka pagrindinius reikalavimus ir kitas svarbias susijusių direktyvų nuostatas. Visą ES atitikties deklaracijos tekstą galima rasti: www.asus.com/support

Norsk ASUSTeK Computer Inc. erklærer herved at denne enheten er i samsvar med hovedsaklige krav og andre relevante forskrifter i relaterte direktiver. Fullstendig tekst for EU-samsvarserklæringen finnes på: www.asus.com/support

Polski Firma ASUSTeK Computer Inc. niniejszym oświadcza, że urządzenie to jest zgodne z zasadniczymi wymogami i innymi właściwymi postanowieniami powiązanych dyrektyw. Pełny tekst deklaracji zgodności UE jest dostępny pod adresem: www.asus.com/support

Portugués A ASUSTeK Computer Inc. declara que este dispositivo está em conformidade com os requisitos essenciais e outras disposições relevantes das Diretivas relacionadas. Texto integral da declaração da UE disponível em: www.asus.com/support

Română ASUSTeK Computer Inc. declară că acest dispozitiv se conformează cerințelor esențiale și altor prevederi relevante ale directivelor conexe. Textul complet al declarației de conformitate a Uniunii Europene se găsește la: www.asus.com/support

Srpski ASUSTeK Computer Inc. ovim izjavljuje da je ovaj uređaj u saglasnosti sa osnovnim zahtevima i drugim relevantnijim odredbama povezanih Direktiva. Pun tekst EU deklaracije o usaglasenosti je dostupan da adres: www.asus.com/support

Slovensky Spoločnosť ASUSTeK Computer Inc. týmto vyhlasuje, že toto zariadenie vyhovuje základným požiadavkám a ostatým príslušným ustanoveniam príslušných smerníc. Celý text vyhlásenia o zhode pre štáty EÚ je dostupný na adrese: www.asus.com/support

Slovenščina ASUSTeK Computer Inc. izjavlja, da je ta naprava skladna z bistvenimi zahtevami in drugimi ustreznimi določbami povezanih direktiv. Celotno besedilo EU-izjave o skladnosti je na voljo na spletnem mestu: www.asus.com/support

Español Por la presente, ASUSTeK Computer Inc. declara que este dispositivo cumple los requisitos básicos y otras disposiciones pertinentes de las directivas relacionadas. El texto completo de la declaración de la UE de conformidad está disponible en: www.asus.com/support

Svenska ASUSTeK Computer Inc. förklarar härmed att denna enhet överensstämmer med de grundläggande kraven och andra relevanta föreskrifter i relaterade direktiv. Fulltext av EU-försäkran om överensstämmelse finns på: www.asus.com/support

Українська ASUSTeK Computer Inc. заявляє, що цей пристрій відповідає основним вимогам та іншим відповідним положенням відповідних Директив. Повний текст декларації відповідності стандартам ЄС доступний на: www.asus.com/support

Türkçe ASUSTeK Computer Inc., bu aygıtın temel gereksinimlerle ve ilişkili Yönergelerin diğer ilgili koşullarıyla uyumlu olduğunu beyan eder. AB uygunluk bildirimini tam metni şu adreste bulunabilir: www.asus.com/support

Bosanski ASUSTeK Computer Inc. ovim izjavljuje da je ovaj uređaj uskladan sa bitnim zahtjevima i ostalim odgovarajućim odredbama vezanih direktiva. Cijeli tekst EU izjave o uskladenosti dostupan je na: www.asus.com/support

Service and Support

Visit our multi-language website at <https://www.asus.com/support/>



Manufacturer	ASUSTek COMPUTER INC.
Address, City	1F, No. 15, Lide Rd., Beitou Dist., Taipei City 112
Authorized Representative in Europe	ASUS COMPUTER GmbH
Address	Harkortstrasse 21-23, 40880 Ratingen
Country	Germany
Authorized Representative in United Kingdom	ASUSTEK (UK) LIMITED
Address	1st Floor, Sackville House, 143-149 Fenchurch Street, London, EC3M 6BL, England
Country	United Kingdom