



THE ULTIMATE FORCE

SABERTOOTH Z97 MARK I

ACCESSORY INSTALLATION GUIDE

ASUS[®]
IN SEARCH OF INCREDIBLE

E8887
First Edition
February 2014

Copyright © 2014 ASUSTeK COMPUTER INC. All Rights Reserved.

No part of this manual, including the products and software described in it, may be reproduced, transmitted, transcribed, stored in a retrieval system, or translated into any language in any form or by any means, except documentation kept by the purchaser for backup purposes, without the express written permission of ASUSTeK COMPUTER INC. ("ASUS").

Product warranty or service will not be extended if: (1) the product is repaired, modified or altered, unless such repair, modification or alteration is authorized in writing by ASUS; or (2) the serial number of the product is defaced or missing.

ASUS PROVIDES THIS MANUAL "AS IS" WITHOUT WARRANTY OF ANY KIND, EITHER EXPRESS OR IMPLIED, INCLUDING BUT NOT LIMITED TO THE IMPLIED WARRANTIES OR CONDITIONS OF MERCHANTABILITY OR FITNESS FOR A PARTICULAR PURPOSE. IN NO EVENT SHALL ASUS, ITS DIRECTORS, OFFICERS, EMPLOYEES OR AGENTS BE LIABLE FOR ANY INDIRECT, SPECIAL, INCIDENTAL, OR CONSEQUENTIAL DAMAGES (INCLUDING DAMAGES FOR LOSS OF PROFITS, LOSS OF BUSINESS, LOSS OF USE OR DATA, INTERRUPTION OF BUSINESS AND THE LIKE), EVEN IF ASUS HAS BEEN ADVISED OF THE POSSIBILITY OF SUCH DAMAGES ARISING FROM ANY DEFECT OR ERROR IN THIS MANUAL OR PRODUCT.

SPECIFICATIONS AND INFORMATION CONTAINED IN THIS MANUAL ARE FURNISHED FOR INFORMATIONAL USE ONLY, AND ARE SUBJECT TO CHANGE AT ANY TIME WITHOUT NOTICE, AND SHOULD NOT BE CONSTRUED AS A COMMITMENT BY ASUS. ASUS ASSUMES NO RESPONSIBILITY OR LIABILITY FOR ANY ERRORS OR INACCURACIES THAT MAY APPEAR IN THIS MANUAL, INCLUDING THE PRODUCTS AND SOFTWARE DESCRIBED IN IT.











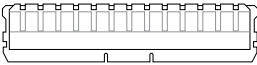

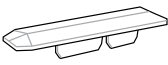
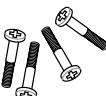

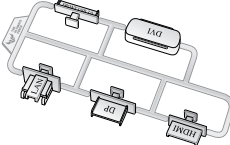
Products and corporate names appearing in this manual may or may not be registered trademarks or copyrights of their respective companies, and are used only for identification or explanation and to the owners' benefit, without intent to infringe.

Contents

Contents	3
Package contents	4
Installing the assistant fans	5
Installing the Dust Defenders	7
Installing the DIMM slot covers	7
Installing the PCIe x16 and PCIe x1 slot covers	7
Installing the onboard connector caps	7
Installing the back I/O caps	8
Installing the back I/O dust filter	8
Installing the Thermistor cable	9
Contact Information	10

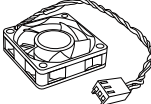
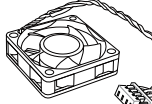
Package contents

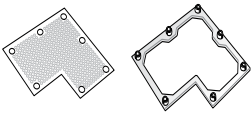
Check your SABERTOOTH Z97 MARK I motherboard package for the following items:

 <p>2 x DIMM slot covers</p>  <p>3 x PCIe x16 slot covers</p>  <p>3 x PCIe x1 slot covers</p>  <p>4 x long screws</p>  <p>2 x short screws</p>	 <p>1 x Connector cap set (LAN cap, HDMI cap, DVI cap, DP cap, Front USB 3.0 cap)</p>  <p>2 x Onboard USB 2.0 connector caps</p>  <p>8 x Back I/O USB 3.0/2.0 connector caps</p>  <p>7 x SATA connector caps</p>  <p>1 x SATA Express connector cap</p>  <p>5 x Audio connector caps</p>	
TUF Connector Dust Defenders package		
TUF Accessory package		
 <p>3 x Thermistor cables</p>	 <p>Dust Grid Dust Frame</p>	 <p>Accessory installation guide (this document)</p>



- If any of the above items is damaged or missing, contact your retailer.
- To support various models, your TUF Connector Dust Defenders package may include additional onboard connector caps and back I/O port caps.
- The illustrated items above are for reference only.

Installing the assistant fans

The SABERTOOTH Z97 MARK I motherboard package comes with a 35 mm and a 40 mm assistant fans for additional cooling solution and better airflow.

To install the 40 mm assistant fan:

1. Locate and remove the screw on the back I/O (A) then remove the back I/O fan cover lid (B).

Keep the screw for later use.

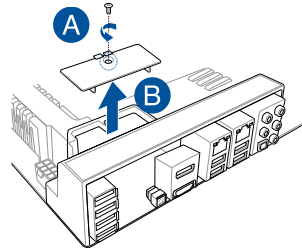

2. Get the bundled 40 mm assistant fan and position it to an orientation where its THE ULTIMATE FORCE logo is facing towards the back I/O shield.
3. Match the two screw holes on the 40 mm assistant fan with the two screw holes on the cover lid and secure it with the bundled set of two (2) screws.

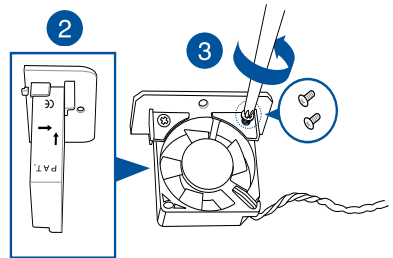

4. Align and insert the cover lid and the assistant fan assembly into the Thermal Armor and secure it with the screw that you removed in step 1.



Ensure to tuck the fan cable inside the cable corner slot.

5. Connect the fan cable connector to the assistant fan (ASST_FAN3) header on the motherboard.
6. Launch the Thermal Radar 2 utility on your computer to adjust the fan's behaviour.



For more information about the Thermal Radar 2 utility, refer to your motherboard's user guide.

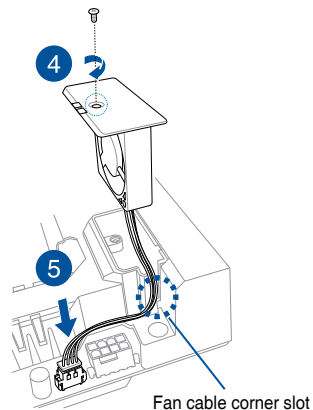

To install the 35 mm assistant fan on the cover hatch:

1. Locate and remove the screws from the cover hatch (A) then remove the lid from the Thermal Armor cover (B).

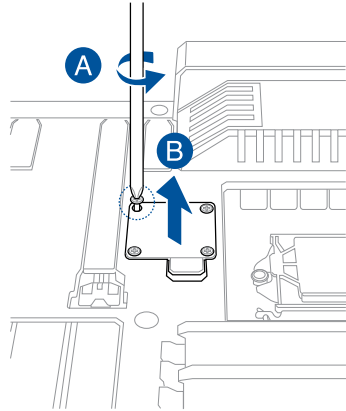

2. Get the 35 mm assistant fan and position it to an orientation where its THE ULTIMATE FORCE logo is facing up.
3. Match the four screw holes on the assistant fan with the four screw holes on the cover hatch and secure it with the bundled set of four (4) long screws for the 35 mm assistant fan.



The screwdriver is not included in the accessory package.

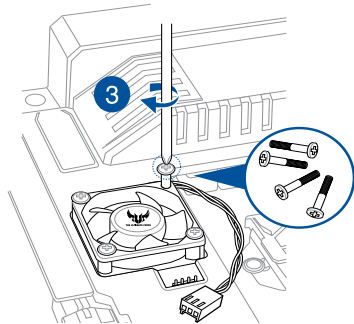

4. Connect the fan cable connector to the assistant fan (ASST_FAN2) header on the motherboard.

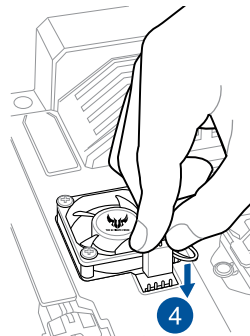

Installing the Dust Defenders

The Dust Defenders are designed to prevent dust and small particles from building up in the motherboard's expansion and memory slots or connectors.

Installing the DIMM slot covers

Install the DIMM slot covers into unused DIMM slots on your motherboard.

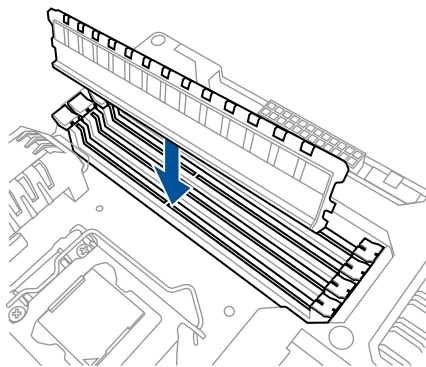

Installing the PCIe x16 and PCIe x1 slot covers

Install the PCIe x16 or PCIe x1 slot covers into unused PCIe x16 or PCIe x1 slots on your motherboard.

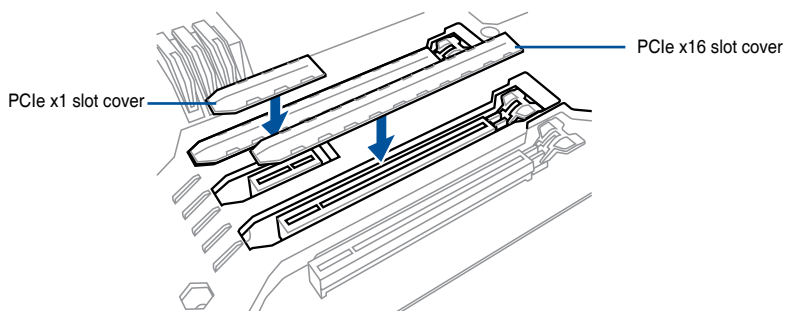

Installing the onboard connector caps

Install the onboard connector caps into unused SATA or Onboard USB 3.0/2.0 connectors on your motherboard.



To support various models, your package may include additional onboard connector caps for your motherboard.

Installing the back I/O caps

The SABERTOOTH Z97 MARK I accessory package takes protection to the next level with the back I/O port caps.

Refer to the illustrated guide for the proper placement of back I/O caps:

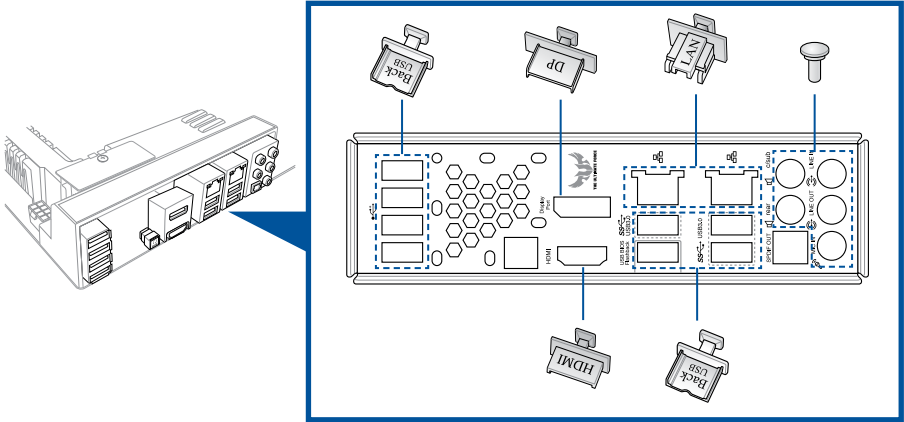

To support various models, your package may include additional back I/O port caps for your motherboard.

Installing the back I/O dust filter

The back I/O dust filter helps reduce the intake of dust and small particles into the system

To install the back I/O dust filter:

1. Match and align seven holes of the back I/O dust grid and seven fasteners of the back I/O dust frame then attach the dust grid to the dust frame.
2. Match and align the seven fasteners of the back I/O dust frame and grid assembly to the seven circular holes on the back I/O fan vent of the I/O shield then push to fasten the back I/O dust grid into the I/O shield with the back I/O dust frame.

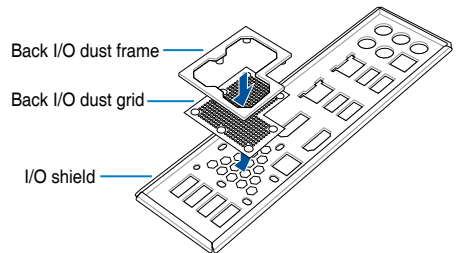

Clean your back I/O dust filter from time to time, especially when it is dirty to ensure optimum airflow.

Installing the Thermistor cable

The Thermistor cable works together with the Thermal Radar 2 utility to allow you to monitor the temperature of selected devices or critical components inside your motherboard.

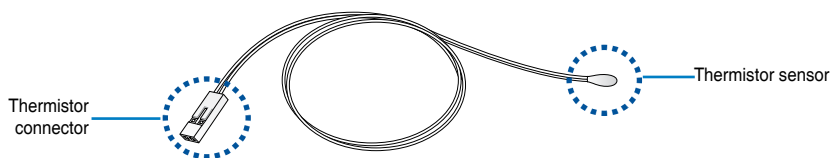

To install the Thermistor cable:

1. Locate the thermal sensor headers labeled T_SENSOR1, T_SENSOR2, or T_SENSOR3 on your motherboard then connect the thermistor cable connector to any of these headers.

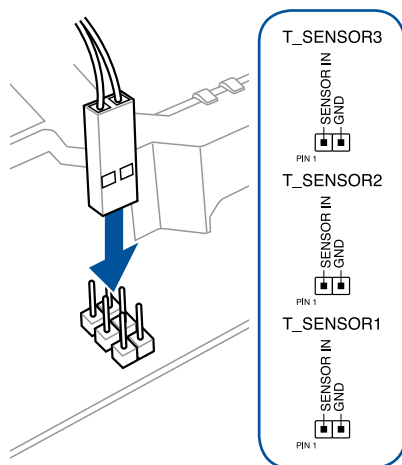

2. Put the thermistor sensor in contact with the surface of the component or part you want to monitor and secure it with an adhesive tape.



The adhesive tape is purchased separately.



The Thermistor sensor operating temperature ranges from 0°C – 80°C.

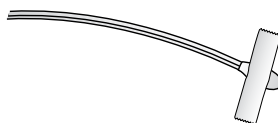

3. Launch the Thermal Radar 2 utility on your computer.

Contact Information

ASUSTeK COMPUTER INC.

Address 15 Li-Te Road, Peitou, Taipei, Taiwan 11259
Telephone +886-2-2894-3447
Fax +886-2-2890-7798
E-mail info@asus.com.tw
Web site <http://www.asus.com>

Technical Support

Telephone +86-21-3842-9911
Fax +86-21-5866-8722, ext. 9101#
Online support <http://support.asus.com/techserv/techserv.aspx>

ASUS COMPUTER INTERNATIONAL (America)

Address 800 Corporate Way, Fremont, CA 94539, USA
Telephone +1-510-739-3777
Fax +1-510-608-4555
Web site <http://usa.asus.com>

Technical Support

Support fax +1-812-284-0883
General support +1-812-282-2787
Online support <http://support.asus.com/techserv/techserv.aspx>

ASUS COMPUTER GmbH (Germany and Austria)

Address Harkort Str. 21-23, 40880 Ratingen, Deutschland
Fax +49-2102-959931
Web site <http://www.asus.de>
Online contact <http://eu-rma.asus.com/sales>

Technical Support

Telephone +49-2102-5789555
Support Fax +49-2102-959911
Online support <http://support.asus.com/techserv/techserv.aspx>

Where to find more information

Visit www.asus.com for additional information and product updates.

