

PRIME X570-PRO

ASUS[®]

Motherboard

E17432
Revised Edition V3
October 2020

Copyright © 2020 ASUSTeK COMPUTER INC. All Rights Reserved.

No part of this manual, including the products and software described in it, may be reproduced, transmitted, transcribed, stored in a retrieval system, or translated into any language in any form or by any means, except documentation kept by the purchaser for backup purposes, without the express written permission of ASUSTeK COMPUTER INC. ("ASUS").

Product warranty or service will not be extended if: (1) the product is repaired, modified or altered, unless such repair, modification or alteration is authorized in writing by ASUS; or (2) the serial number of the product is defaced or missing.

ASUS PROVIDES THIS MANUAL "AS IS" WITHOUT WARRANTY OF ANY KIND, EITHER EXPRESS OR IMPLIED, INCLUDING BUT NOT LIMITED TO THE IMPLIED WARRANTIES OR CONDITIONS OF MERCHANTABILITY OR FITNESS FOR A PARTICULAR PURPOSE. IN NO EVENT SHALL ASUS, ITS DIRECTORS, OFFICERS, EMPLOYEES OR AGENTS BE LIABLE FOR ANY INDIRECT, SPECIAL, INCIDENTAL, OR CONSEQUENTIAL DAMAGES (INCLUDING DAMAGES FOR LOSS OF PROFITS, LOSS OF BUSINESS, LOSS OF USE OR DATA, INTERRUPTION OF BUSINESS AND THE LIKE), EVEN IF ASUS HAS BEEN ADVISED OF THE POSSIBILITY OF SUCH DAMAGES ARISING FROM ANY DEFECT OR ERROR IN THIS MANUAL OR PRODUCT.

SPECIFICATIONS AND INFORMATION CONTAINED IN THIS MANUAL ARE FURNISHED FOR INFORMATIONAL USE ONLY, AND ARE SUBJECT TO CHANGE AT ANY TIME WITHOUT NOTICE, AND SHOULD NOT BE CONSTRUED AS A COMMITMENT BY ASUS. ASUS ASSUMES NO RESPONSIBILITY OR LIABILITY FOR ANY ERRORS OR INACCURACIES THAT MAY APPEAR IN THIS MANUAL, INCLUDING THE PRODUCTS AND SOFTWARE DESCRIBED IN IT.

Products and corporate names appearing in this manual may or may not be registered trademarks or copyrights of their respective companies, and are used only for identification or explanation and to the owners' benefit, without intent to infringe.

Contents

Safety information.....	v
About this guide.....	vi
PRIME X570-PRO specifications summary.....	viii
Package contents.....	xii
Installation tools and components.....	xiii

Chapter 1: Product Introduction

1.1	Motherboard overview.....	1-1
1.1.1	Before you proceed.....	1-1
1.1.2	Motherboard layout.....	1-2
1.1.3	Central Processing Unit (CPU).....	1-4
1.1.4	System memory.....	1-4
1.1.5	Expansion slots.....	1-6
1.1.6	Onboard LEDs.....	1-8
1.1.7	Headers.....	1-9
1.1.8	Internal connectors.....	1-12

Chapter 2: Basic Installation

2.1	Building your PC system.....	2-1
2.1.1	CPU installation.....	2-1
2.1.2	Cooling system installation.....	2-2
2.1.3	Motherboard installation.....	2-5
2.1.4	DIMM installation.....	2-6
2.1.5	ATX power connection.....	2-7
2.1.6	SATA device connection.....	2-8
2.1.7	Front I/O connector.....	2-9
2.1.8	Expansion card installation.....	2-10
2.1.9	M.2 installation.....	2-11
2.2	Motherboard rear and audio connections.....	2-13
2.2.1	Rear I/O connection.....	2-13
2.2.2	Audio I/O connections.....	2-15
2.3	Starting up for the first time.....	2-17
2.4	Turning off the computer.....	2-17

Chapter 3: BIOS Setup

3.1	Knowing BIOS.....	3-1
3.2	BIOS Setup program.....	3-2
3.2.1	EZ Mode.....	3-3
3.2.2	Advanced Mode.....	3-4
3.2.3	Q-Fan Control.....	3-7

3.2.4	EZ Tuning Wizard	3-9
3.3	My Favorites	3-10
3.4	Main menu	3-11
3.5	Ai Tweaker menu	3-12
3.6	Advanced menu	3-13
3.6.1	AMD fTPM Configuration	3-13
3.6.2	CPU Configuration	3-13
3.6.3	NB Configuration	3-14
3.6.4	SATA Configuration	3-14
3.6.5	Onboard Devices Configuration	3-15
3.6.6	APM Configuration	3-16
3.6.7	PCI Subsystem Settings	3-16
3.6.8	USB Configuration	3-16
3.6.9	HDD/SSD SMART Information	3-17
3.6.10	Network Stack Configuration	3-17
3.7	Monitor menu	3-17
3.7.1	Q-Fan Configuration	3-17
3.8	Boot menu	3-17
3.8.1	Boot Configuration	3-17
3.8.2	CSM (Compatibility Support Module)	3-18
3.8.3	Secure Boot	3-18
3.9	Tool menu	3-18
3.9.1	ASUS EZ Flash 3 Utility	3-18
3.9.2	ASUS User Profile	3-18
3.9.3	ASUS SPD Information	3-19
3.9.4	Graphics Card Information	3-19
3.9.5	ASUS Armoury Crate	3-19
3.10	Exit menu	3-19
3.11	Updating BIOS	3-20
3.11.1	EZ Update	3-20
3.11.2	ASUS EZ Flash 3	3-21
3.11.3	ASUS CrashFree BIOS 3	3-22

Appendix

Notices	A-1
ASUS contact information	A-5

Safety information

Electrical safety

- To prevent electrical shock hazards, disconnect the power cable from the electrical outlet before relocating the system.
- When adding or removing devices to or from the system, ensure that the power cables for the devices are unplugged before the signal cables are connected. If possible, disconnect all power cables from the existing system before you add a device.
- Before connecting or removing signal cables from the motherboard, ensure that all power cables are unplugged.
- Seek professional assistance before using an adapter or extension cord. These devices could interrupt the grounding circuit.
- Ensure that your power supply is set to the correct voltage in your area. If you are not sure about the voltage of the electrical outlet you are using, contact your local power company.
- If the power supply is broken, do not try to fix it by yourself. Contact a qualified service technician or your retailer.

Operation safety

- Before installing the motherboard and adding devices on it, carefully read all the manuals that came with the package.
- Before using the product, ensure all cables are correctly connected and the power cables are not damaged. If you detect any damage, contact your dealer immediately.
- To avoid short circuits, keep paper clips, screws, and staples away from connectors, slots, sockets and circuitry.
- Avoid dust, humidity, and temperature extremes. Do not place the product in any area where it may become wet.
- Place the product on a stable surface.
- If you encounter technical problems with the product, contact a qualified service technician or your retailer.

About this guide

This user guide contains the information you need when installing and configuring the motherboard.

How this guide is organized

This guide contains the following parts:

- **Chapter 1: Product Introduction**
This chapter describes the features of the motherboard and the new technology it supports. It includes description of the switches, jumpers, and connectors on the motherboard.
- **Chapter 2: Basic Installation**
This chapter lists the hardware setup procedures that you have to perform when installing system components.
- **Chapter 3: BIOS Setup**
This chapter tells how to change system settings through the BIOS Setup menus. Detailed descriptions of the BIOS parameters are also provided.

Where to find more information

Refer to the following sources for additional information and for product and software updates.

1. **ASUS website**
The ASUS website (www.asus.com) provides updated information on ASUS hardware and software products.
2. **Optional documentation**
Your product package may include optional documentation, such as warranty flyers, that may have been added by your dealer. These documents are not part of the standard package.

Conventions used in this guide

To ensure that you perform certain tasks properly, take note of the following symbols used throughout this manual.



DANGER/WARNING: Information to prevent injury to yourself when trying to complete a task.



CAUTION: Information to prevent damage to the components when trying to complete a task.



IMPORTANT: Instructions that you **MUST** follow to complete a task.



NOTE: Tips and additional information to help you complete a task.

Typography

Bold text

Indicates a menu or an item to select.

Italics

Used to emphasize a word or a phrase.

<Key>

Keys enclosed in the less-than and greater-than sign means that you must press the enclosed key.

Example: <Enter> means that you must press the Enter or Return key.

<Key1> + <Key2> + <Key3>

If you must press two or more keys simultaneously, the key names are linked with a plus sign (+).

PRIME X570-PRO specifications summary

CPU	<p>AMD AM4 Socket for 3rd and 2nd Gen AMD Ryzen™ /2nd and 1st Gen AMD Ryzen™ with Radeon™ Vega Graphics Processors</p> <p>Supports CPU up to 16 cores*</p> <p>* Due to the CPU limitations, CPU cores supported vary by processor. ** Refer to www.asus.com for the AMD CPU support list.</p>
Chipset	AMD X570 Chipset
Memory	<p>3rd Gen AMD Ryzen™ Processors</p> <p>- 4 x DIMM, max. 128GB, DDR4 4400(O.C.)/4266(O.C.)/4133(O.C.)/4000(O.C.)/3866(O.C.)/3733(O.C.)/3600(O.C.)/3466(O.C.)/3400(O.C.)/3200/3000/2933/2800/2666/2400/2133 MHz, un-buffered memory</p> <p>2nd Gen AMD Ryzen™ Processors</p> <p>- 4 x DIMM, max. 128GB, DDR4 3600(O.C.)/3466(O.C.)/3400(O.C.)/3200(O.C.)/3000(O.C.)/2933/2800/2666/2400/2133 MHz, un-buffered memory</p> <p>2nd and 1st Gen AMD Ryzen™ with Radeon™ Vega Graphics Processors</p> <p>- 4 x DIMM, max. 128GB, DDR4 3200(O.C.)/3000(O.C.)/2933/2800/2666/2400/2133 MHz, un-buffered memory</p> <p>Dual channel memory architecture</p> <p>ECC Memory (ECC mode) support varies by CPU.</p> <p>* Refer to www.asus.com for the Memory QVL (Qualified Vendors List). ** The maximum memory capacity supported vary depending on the CPU you installed.</p>
Expansion slots	<p>3rd Gen AMD Ryzen™ Processors</p> <p>- 2 x PCIe 4.0 x16 slots (single at x16 or dual at x8/x8 mode)</p> <p>2nd Gen AMD Ryzen™ Processors</p> <p>- 2 x PCIe 3.0 x16 slots (single at x16 or dual at x8/x8 mode)</p> <p>2nd and 1st Gen AMD Ryzen™ with Radeon™ Vega Graphics Processors</p> <p>- 1 x PCIe 3.0 x16 slot (at x8 mode)</p> <p>AMD X570 chipset</p> <p>- 1 x PCIe 4.0 x16 slot (max. at x4 mode)</p> <p>- 3 x PCIe 4.0 x1 slots</p>
Graphics	<p>Integrated Graphics in the 2nd and 1st Gen AMD Ryzen™ with Radeon™ Vega Graphics Processors</p> <p>Multi-VGA output support: DisplayPort/HDMI ports</p> <p>- Supports DisplayPort 1.2 with max. resolution of 4096 x 2160 @60Hz</p> <p>- Supports HDMI 2.0b with max. resolution of 4096 x 2160 @60Hz</p>

(continued on the next page)

PRIME X570-PRO specifications summary

<p>Multi-GPU support</p>	<p>3rd and 2nd Gen AMD Ryzen™ Processors</p> <ul style="list-style-type: none"> - Supports NVIDIA® 2-Way SLI® Technology - Supports AMD 3-Way CrossFireX™ Technology <p>2nd and 1st Gen AMD Ryzen™ with Radeon™ Vega Graphics Processors</p> <ul style="list-style-type: none"> - Supports AMD 2-Way CrossFireX™ Technology
<p>Storage</p>	<p>3rd Gen AMD Ryzen™ Processors</p> <ul style="list-style-type: none"> - M.2_1 socket 3 with M Key, Type 2242/2260/2280/22110(PCIE 4.0 x4 and SATA modes) storage devices support <p>2nd Gen AMD Ryzen™/2nd and 1st Gen AMD Ryzen™ with Radeon™ Vega Graphics Processors</p> <ul style="list-style-type: none"> - M.2_1 socket 3 with M Key, Type 2242/2260/2280/22110(PCIE 3.0 x4 and SATA modes) storage devices support <p>AMD X570 Chipset:</p> <ul style="list-style-type: none"> - M.2_2 socket 3 with M Key, Type 2242/2260/2280/22110 (PCIE 4.0 x 4 and SATA modes) storage devices support - 6 x Serial ATA 6.0 Gb/s connectors with RAID 0, RAID 1 and RAID 10 support
<p>LAN</p>	<p>Intel® I211AT Gigabit LAN</p>
<p>Audio</p>	<p>Realtek® S1220A 8-channel high definition audio CODEC featuring Crystal Sound 3</p> <ul style="list-style-type: none"> - Separate layer for left and right track, ensuring both sound deliver equal quality - Impedance sense for front and rear headphone outputs - Audio shielding ensures precise analog/digital separation and greatly reduced multi-lateral interference - EMI protection cover to prevent electrical noise to affect the amplifier quality - Internal audio Amplifier to enhance the highest quality sound for headphone and speakers - Premium Japan-made audio capacitors provides warm, natural, and immersive sound with exceptional clarity and fidelity - High quality 120dB SNR stereo playback output (Line-out@back) & 113dB SNR input (Line-in) support - Supports up to 32-Bit/192kHz playback* - Supports jack-detection, multi-streaming, front panel jack-retasking (MIC) - Optical S/PDIF out port at back I/O <p>* Due to limitations in HDA bandwidth, 32-Bit/192kHz is not supported for 8-Channel audio.</p>
<p>USB</p>	<p>3rd and 2nd Gen AMD Ryzen™/2nd and 1st Gen AMD Ryzen™ with Radeon™ Vega Graphics Processors</p> <ul style="list-style-type: none"> - 4 x USB 3.2 Gen 1(up to 5Gbps) ports (4 ports at back panel)

(continued on the next page)

PRIME X570-PRO specifications summary

USB	AMD X570 chipset <ul style="list-style-type: none">- 1 x USB 3.2 Gen 2 (up to 10Gbps) front connector- 4 x USB 3.2 Gen 2 (up to 10Gbps) ports (3*Type A+1*Type C at back panel)- 2 x USB 3.2 Gen 1 (up to 5Gbps) ports (2 ports at mid-board)- 4 x USB 2.0 ports at mid-board
ASUS Unique Features	Performance Optimization 5-Way Optimization <ul style="list-style-type: none">- Whole system optimization with a single click! Perfectly consolidates TPU Insight, EPU Guidance, DIGI+ VRM, Fan Expert 4, and Turbo App DIGI+VRM <ul style="list-style-type: none">- Digital power design with DrMOS EPU <ul style="list-style-type: none">- EPU Guidance TPU <ul style="list-style-type: none">- TPU Insight Fan Xpert 4 <ul style="list-style-type: none">- featuring Fan Auto Tuning function and multiple thermistors selection for optimized system cooling control Turbo App <ul style="list-style-type: none">- featuring system performance tuning, network priority, and audio scene configuration for selected applications Armoury Crate Visual Beauty <ul style="list-style-type: none">- Aura Lighting Control- Addressable Gen2 Header- Aura RGB Strip Headers ASUS Q-Design <ul style="list-style-type: none">- ASUS Q-Slot- ASUS Q-DIMM- ASUS Q-Connector- ASUS Q-LED (CPU, DRAM, VGA, Boot Device LED) ASUS Exclusive Features <ul style="list-style-type: none">- OptiMem- Turbo LAN- ASUS Ai Charger- ASUS AI Suite 3

(continued on the next page)

PRIME X570-PRO specifications summary

<p>Special Features</p>	<p>ASUS SafeSlot - Protect your graphics card Investment</p> <p>ASUS 5X Protection III</p> <ul style="list-style-type: none"> - ASUS SafeSlot Core - Fortified PCIe with solid soldering - ASUS LANGuard - Protects against LAN surges, lightning strikes and static-electricity discharges! - ASUS Overvoltage Protection - World-class circuit-protecting power design - ASUS DIGI+ VRM - Digital power design with DrMOS - ASUS DRAM Overcurrent Protection: Enhanced DRAM overcurrent protection - ASUS Stainless-Steel Back I/O: 3X corrosion-resistance for greater durability! - ASUS ESD Guards - Enhanced ESD protection
<p>ASUS Quiet Thermal Solution</p>	<p>Quiet Thermal Design:</p> <ul style="list-style-type: none"> - ASUS Fan Xpert 4 - Stylish Design: MOS Heat-sink with dual thermal pads design, PCH Fan, PCH and M.2 Heatsink
<p>Back I/O Ports</p>	<p>1 x PS/2 keyboard/mouse combo port</p> <p>1 x DisplayPort</p> <p>1 x HDMI port</p> <p>1 x Intel LAN (RJ45) port</p> <p>3 x USB 3.2 Gen 2 (up to 10Gbps) ports (Type-A)</p> <p>1 x USB 3.2 Gen 2 (up to 10Gbps) port (Type-C)</p> <p>4 x USB 3.2 Gen 1 (up to 5Gbps) ports (blue, Type-A)</p> <p>1 x Optical S/PDIF out</p> <p>5 x Audio Jacks (Line in, Front Speaker Out, Mic in, Center/Subwoofer, Rear Speaker Out)</p>
<p>Internal I/O Ports</p>	<p>1 x USB 3.2 Gen 2 (up to 10Gbps) connector</p> <p>1 x USB 3.2 Gen 1 (up to 5Gbps) connector supports an additional 2 USB ports</p> <p>2 x USB 2.0 connectors support additional 4 USB ports</p> <p>1 x M.2_1 Socket 3 for M Key, type 2242/2260/2280/22110 devices support, (both SATA & PCIe mode)</p> <p>1 x M.2_2 Socket 3 for M Key, type 2242/2260/2280/22110 devices support, (both SATA & PCIe mode)</p> <p>6 x SATA 6.0Gb/s connectors (gray)</p> <p>1 x CPU Fan header (4-pin) for both 3-pin(DC mode) and 4-pin(PWM mode) CPU coolers control with auto detection support</p> <p>1 x CPU OPT Fan header (4-pin)</p> <p>1 x AIO Pump header (4-pin)</p> <p>1 x W_PUMP+ header (4-pin)</p> <p>1 x PCH _FAN connector (4-pin)</p> <p>3 x Chassis Fan connectors (4-pin) for both 3-pin(DC mode) and 4-pin(PWM mode) coolers control with auto detection support</p> <p>2 x AURA RGB headers</p> <p>1 x Addressable Gen 2 header</p>

(continued on the next page)

PRIME X570-PRO specifications summary

Internal I/O Ports	<ul style="list-style-type: none"> 1 x Front panel audio connector (AAFP) 1 x SPL_TPM connector 1 x COM connector 1 x 24-pin EATX Power connector 1 x 8-pin EATX 12V Power connector 1 x 4-pin EATX 12V Power connector 1 x System Panel Connector 1 x Clear CMOS header 1 x Node Connector 1 x Power-on button 1 x T_Sensor Header
BIOS	256 Mb Flash ROM, UEFI AMI BIOS, PnP, SM BIOS 3.2, ACPI 6.2, Multi-language BIOS, ASUS EZ Flash 3, CrashFree BIOS 3, F6 Qfan Control, F3 My Favorites, Last Modified log, F12 PrintScreen, F4 AURA ON/OFF, F9 Search, F11 EZ Tuning Wizard and ASUS DRAM SPD (Serial Presence Detect) memory information
Manageability	WOL by PME, PXE
Support DVD contents	<ul style="list-style-type: none"> Drivers ASUS Utilities EZ Update
Operating System Support	Windows 10 64-bit
Form Factor	ATX Form Factor, 12"x 9.6" (30.5cm x 24.4cm)



- Specifications are subject to change without notice.
- visit the ASUS website for the software manual

Package contents



Check your motherboard package for the following items.

Motherboard	1 x PRIME X570-PRO
Cables	<ul style="list-style-type: none"> 2 x SATA 6 Gb/s cables 1 x Addressable LED extension cable
Accessories	<ul style="list-style-type: none"> 1 x Q-connector 1 x M.2 Screw Package
Application DVD	Motherboard support DVD
Documentation	User guide

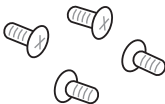

If any of the above items are damaged or missing, contact your retailer.

Installation tools and components

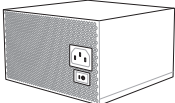
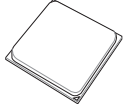
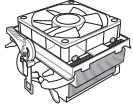
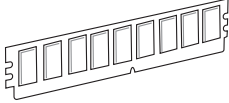
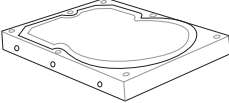
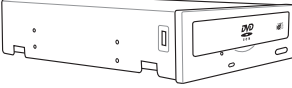
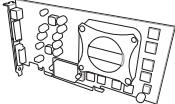
	
1 Bag of screws	Phillips (cross) screwdriver
	
PC chassis	Power supply unit
	
AMD AM4 CPU	AMD AM4/AM3 compatible CPU Fan
	
DDR4 DIMM	SATA hard disk drive
	
SATA optical disc drive (optional)	Graphics card (optional)



The tools and components in the table above are not included in the motherboard package.

Product Introduction

1

1.1 Motherboard overview

1.1.1 Before you proceed

Take note of the following precautions before you install motherboard components or change any motherboard settings.



-
- Unplug the power cord from the wall socket before touching any component.
 - Before handling components, use a grounded wrist strap or touch a safely grounded object or a metal object, such as the power supply case, to avoid damaging them due to static electricity.
 - Hold components by the edges to avoid touching the ICs on them.
 - Whenever you uninstall any component, place it on a grounded antistatic pad or in the bag that came with the component.
 - Before you install or remove any component, ensure that the ATX power supply is switched off or the power cord is detached from the power supply. Failure to do so may cause severe damage to the motherboard, peripherals, or components.
-

1.1.2 Motherboard layout

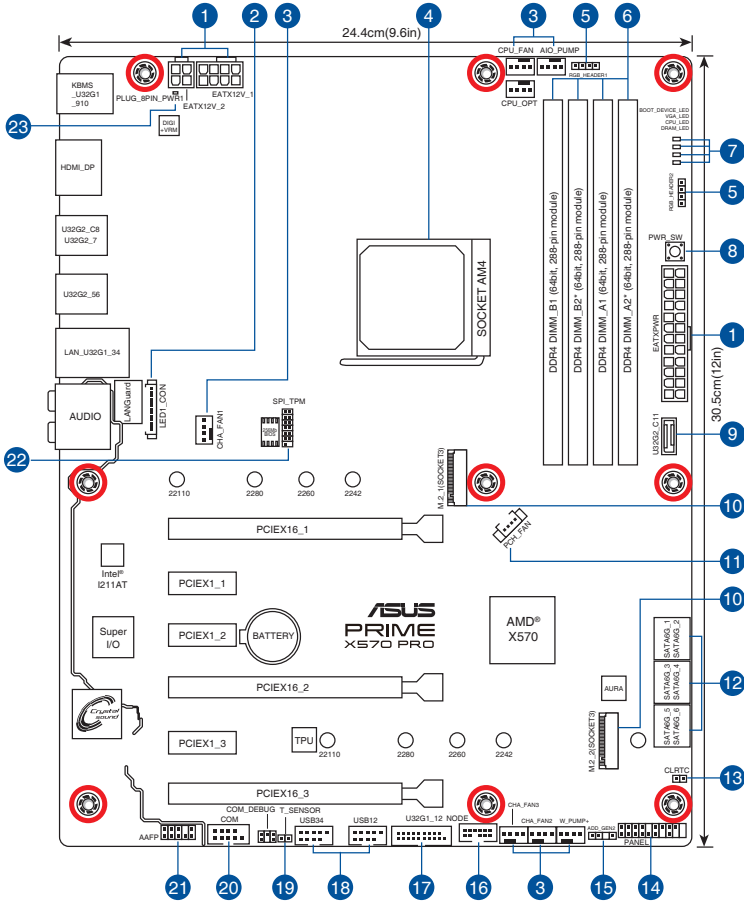

Refer to **1.1.8 Internal connectors** and **2.2.1 Rear I/O connection** for more information about rear panel connectors and internal connectors.

Layout contents

Connectors/Jumpers/Buttons and switches/Slots	Page
1. ATX power connectors (24-pin EATXPWR; 8-pin EATX12V; 4-pin EATX 12V;)	1-18
2. LED connector (13-pin LED_CON)	1-19
3. CPU, CPU optional, and chassis fan connectors; water pump+, and AIO pump connectors (4-pin CPU_FAN, 4-pin CPU_OPT, 4-pin CHA_FAN1-3; 4-pin W_PUMP+, 4-pin AIO_PUMP)	1-17
4. AM4 CPU socket	1-4
5. AURA RGB headers (4-pin RGB_HEADER1-2)	1-10
6. DDR4 DIMM slots	1-4
7. Q LEDs	1-8
8. Power-on button (PWR_SW)	1-20
9. USB 3.2 Gen 2 (up to 10Gbps) front panel connector (U32G2_C11)	1-14
10. M.2 Socket 3	1-21
11. PCH fan header (4-pin PCH_FAN)	1-18
12. AMD Serial ATA 6 Gb/s connectors (7-pin SATA6G_1-6)	1-13
13. Clear RTC RAM jumper (2-pin CLRTC)	1-9
14. System panel connectors (20-5 pin PANEL)	1-16
15. Addressable Gen 2 header (4-1 pin ADD_GEN2)	1-11
16. Node connector (12-1 pin NODE)	1-20
17. USB 3.2 Gen 1 (up to 5Gbps) connector (20-1 pin U32G1_12)	1-14
18. USB 2.0 connectors (10-1 pin USB12, USB34)	1-15
19. Thermal sensor connector (2-pin T_SENSOR)	1-15
20. Serial port connector (10-1 pin COM)	1-19
21. Front panel audio connector (10-1 pin AAFP)	1-12
22. SPI_TPM connector (14-1 pin SPI_TPM)	1-12
23. 8-pin power plug LED	1-22

1.1.3 Central Processing Unit (CPU)

The motherboard comes with an AM4 socket designed for 3rd and 2nd AMD Ryzen™ /2nd and 1st Gen AMD Ryzen™ with Radeon™ Vega Graphics Processors up to 16 cores.

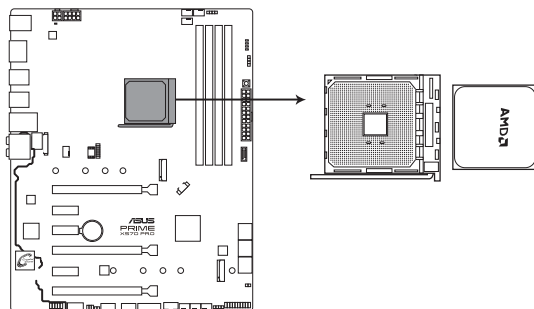

PRIME X570-PRO CPU socket AM4



The AM4 socket has a different pinout design. Ensure that you use a CPU designed for the AM4 socket. The CPU fits in only one correct orientation. **DO NOT** force the CPU into the socket to prevent bending the connectors on the socket and damaging the CPU!



Ensure that all power cables are unplugged before installing the CPU.

1.1.4 System memory

The motherboard comes with four Double Data Rate 4 (DDR4) Dual Inline Memory Modules (DIMM) slots.



A DDR4 module is notched differently from a DDR, DDR2, or DDR3 module. **DO NOT** install a DDR, DDR2, or DDR3 memory module to the DDR4 slot.

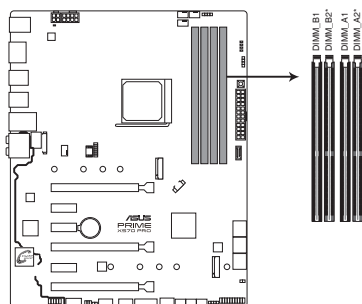

PRIME X570-PRO 288-pin DDR4 DIMM sockets

Recommended memory configurations

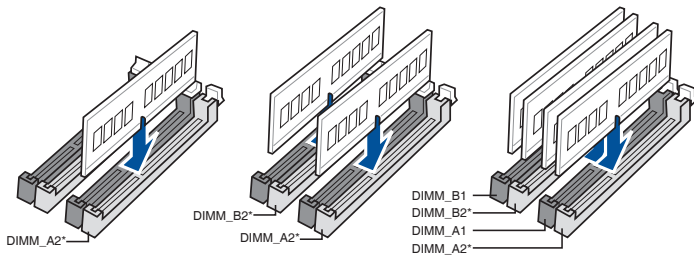

Memory configurations

You may install 2 GB, 4 GB, 8 GB, 16 GB and 32 GB unbuffered DDR4 DIMMs into the DIMM sockets.



- The default memory operation frequency is dependent on its Serial Presence Detect (SPD), which is the standard way of accessing information from a memory module. Under the default state, some memory modules for overclocking may operate at a lower frequency than the vendor-marked value.
- For system stability, use a more efficient memory cooling system to support a full memory load (4 DIMMs) or overclocking condition.
- Always install the DIMMs with the same CAS Latency. For an optimum compatibility, we recommend that you install memory modules of the same version or data code (D/C) from the same vendor. Check with the vendor to get the correct memory modules.
- Visit the ASUS website for the latest QVL same vendor. Check with the vendor to get the correct memory modules.

1.1.5 Expansion slots



Unplug the power cord before adding or removing expansion cards. Failure to do so may cause you physical injury and damage motherboard components.

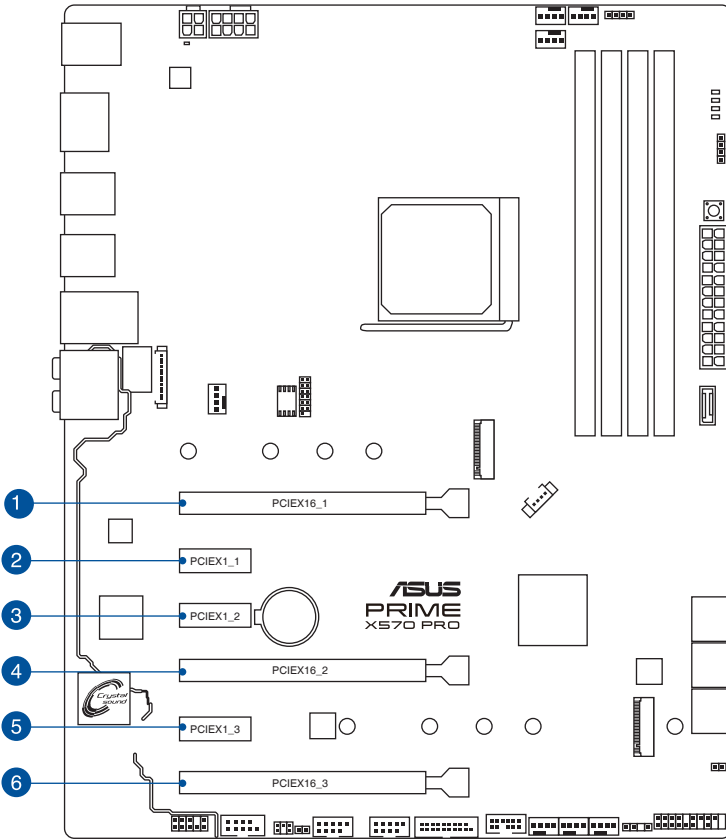

Slot No.	Slot Description
1	PCIe 4.0 / 3.0 x16_1 slot
2	PCIe 4.0 x1_1 slot
3	PCIe 4.0 x1_2 slot
4	PCIe 4.0 / 3.0 x16_2 slot
5	PCIe 4.0 x1_3 slot
6	PCIe 4.0 x16_3 slot

3rd Gen AMD Ryzen™ Processors

VGA Configuration	PCIe operating mode	
	PCIe 4.0 x16_1	PCIe 4.0 x16_2
Single VGA/PCIe card	x16	N/A
Dual VGA/PCIe card	x8	x8

2nd Gen AMD Ryzen™ Processors

VGA Configuration	PCIe operating mode	
	PCIe 3.0 x16_1	PCIe 3.0 x16_2
Single VGA/PCIe card	x16	N/A
Dual VGA/PCIe card	x8	x8

2nd and 1st Gen AMD Ryzen™ with Radeon™ Vega Graphics Processors

VGA Configuration	PCIe 3.0 x16_1
	Single VGA/PCIe card



- We recommend that you provide sufficient power when running CrossFireX or SLI® mode.
- Connect chassis fans to the motherboard chassis fan connectors when using multiple graphics cards for better thermal environment.

1.1.6 Onboard LEDs

1. Q LEDs (BOOT_LED, VGA_LED, DRAM_LED, CPU_LED)

Q LEDs check key components (CPU, DRAM, VGA card, and booting devices) in sequence during motherboard booting process. If an error is found, the corresponding LED remains lit until the problem is solved. This user-friendly design provides an intuitive way to locate the root problem within seconds.

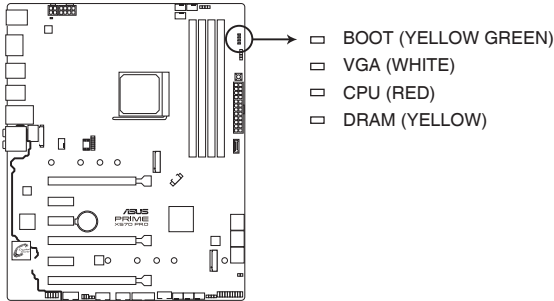

PRIME X570-PRO CPU/DRAM/BOOT_DEVICE/VGA LED



The Q LEDs provide the most probable cause of an error code as a starting point for troubleshooting. The actual cause may vary from case to case.

1.1.7 Headers

1. Clear RTC RAM jumper (2-pin CLRRTC)

This jumper allows you to clear the CMOS RTC RAM data of the system setup information such as date, time, and system passwords.

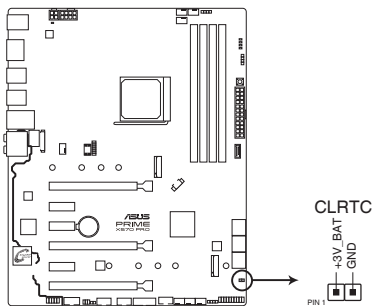

PRIME X570-PRO Clear RTC RAM

To erase the RTC RAM:

1. Turn OFF the computer and unplug the power cord.
2. Use a metal object such as a screwdriver to short the two pins.
3. Plug the power cord and turn ON the computer.
4. Hold down the key during the boot process and enter BIOS Setup to re-enter data.



If the steps above do not help, remove the onboard battery and short the two pins again to clear the CMOS RTC RAM data. After clearing the CMOS, reinstall the battery.

2. AURA RGB headers (4-pin RGB_HEADER1-2)

These connectors are for RGB LED strips.

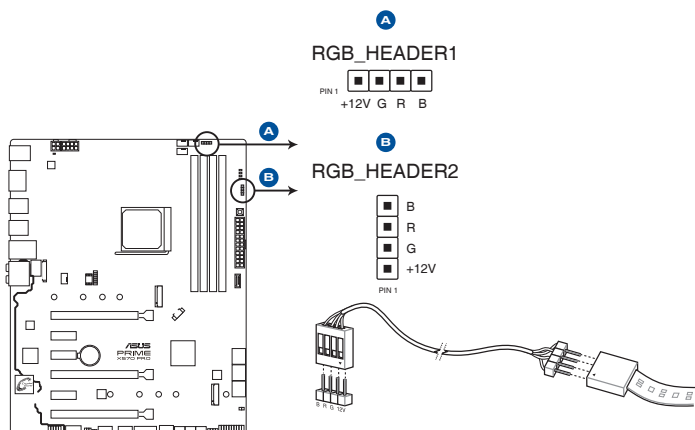

PRIME X570-PRO RGB_HEADER connectors



The RGB header supports 5050 RGB multi-color LED strips (12V/G/R/B), with a maximum power rating of 3A (12V), and no longer than 3 m.



Before you install or remove any component, ensure that the ATX power supply is switched off or the power cord is detached from the power supply. Failure to do so may cause severe damage to the motherboard, peripherals, or components.



- Actual lighting and color will vary with LED strip.
- If your LED strip does not light up, check if the RGB LED extension cable and the RGB LED strip are connected in the correct orientation, and the 12V connector is aligned with the 12V header on the motherboard.
- The LED strip will only light up while the system is operational.
- The LED strip is purchased separately.

3. Addressable RGB Gen 2 header (4-1 pin ADD_GEN2)

This connector is for individually addressable RGB WS2812B LED strips or WS2812B based LED strips.

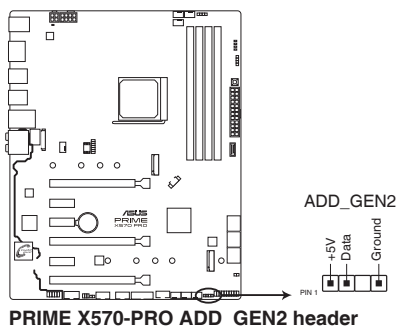

The addressable gen 2 RGB header supports WS2812B addressable RGB LED strips (5V/ Data/Ground), with a maximum power rating of 3A (5V) and a maximum of 120 LEDs



Before you install or remove any component, ensure that the ATX power supply is switched off or the power cord is detached from the power supply. Failure to do so may cause severe damage to the motherboard, peripherals, or components



- Actual lighting and color will vary with LED strip.
- If your LED strip does not light up, check if the RGB LED extension cable and the RGB LED strip are connected in the correct orientation, and the 12V connector is aligned with the 12V header on the motherboard.
- The LED strip will only light up while the system is operational.
- The LED strip is purchased separately.

1.1.8 Internal connectors

1. Front panel audio connector (10-1 pin AAFP)

This connector is for a chassis-mounted front panel audio I/O module that supports HD Audio. Connect one end of the front panel audio I/O module cable to this connector.

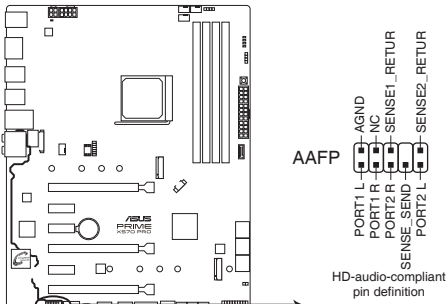

PRIME X570-PRO front panel audio connector



We recommend that you connect a high-definition front panel audio module to this connector to avail of the motherboard's high-definition audio capability.

2. SPI_TPM connector (14-1 pin SPI_TPM)

This connector supports a Trusted Platform Module (TPM) system with a Serial Peripheral Interface (SPI), allowing you to securely store keys, digital certificates, passwords and data. A TPM system also enhances network security, protects digital identities, and ensures platform integrity.

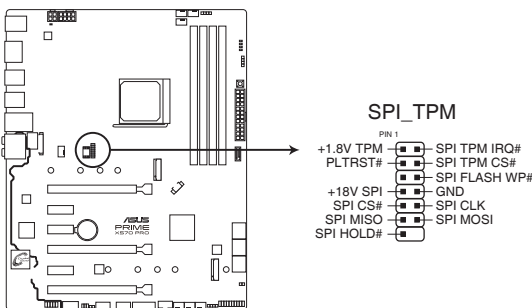

PRIME X570-PRO SPI_TPM connector



The SPI_TPM module is purchased separately.

3. AMD Serial ATA 6 Gb/s connectors (7-pin SATA6G_1-6)

These connectors connect to Serial ATA 6 Gb/s hard disk drives via Serial ATA 6 Gb/s signal cables.

If you installed Serial ATA hard disk drives, you can create a RAID 0, RAID 1, and RAID 10 configuration through the onboard AMD X570 chipset.

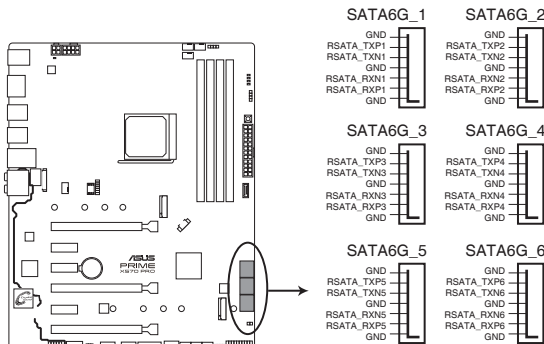

PRIME X570-PRO SATA 6 Gb/s connectors

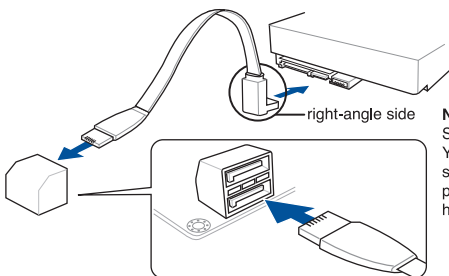

NOTE: Connect the right-angle side of SATA signal cable to SATA device. You may also connect the right-angle side of SATA cable to the onboard SATA port to avoid mechanical conflict with huge graphics cards.



- These connectors are set to **[AHCI]** by default. If you intend to create a Serial ATA RAID set using these connectors, set the SATA Mode Selection item in the BIOS to **[RAID]**.
- Before creating a RAID set, refer to section **RAID configurations** or the manual bundled in the motherboard support DVD.
- When using NCQ, set the SATA Mode in the BIOS to **[AHCI]**. Refer to section **SATA Configuration** for details.

4. USB 3.2 Gen 2 (up to 10Gbps) front panel connector (U32G2_C11)

This connector allows you to connect a USB 3.2 Gen 2 module for additional USB 3.2 Gen 2 ports. The latest USB 3.2 Gen 2 connectivity provides data transfer speeds of up to 10 Gbps. The next-generation standard is completely backward-compatible with your existing USB devices.

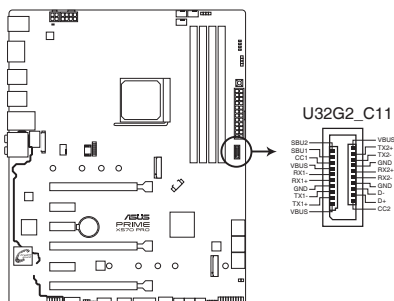

PRIME X570-PRO USB3.2 Gen2 front panel connector

5. USB 3.2 Gen 1 (up to 5Gbps) connector (20-1 pin U32G1_12)

This connector allows you to connect a USB 3.2 Gen 1 module for additional USB 3.2 Gen 1 front or rear panel ports. With an installed USB 3.2 Gen 1 module, you can enjoy all the benefits of USB 3.2 Gen 1 including faster data transfer speeds of up to 5 Gb/s, faster charging time for USB-chargeable devices, optimized power efficiency, and backward compatibility with USB 2.0.

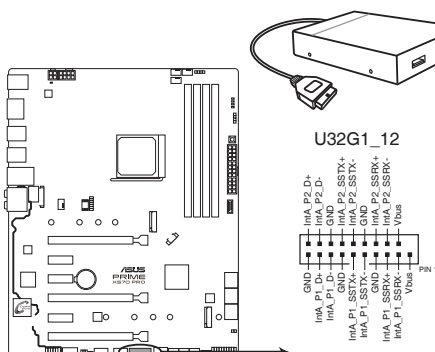

PRIME X570-PRO USB 3.2 Gen1 connector



The USB 3.2 Gen 1 module is purchased separately.



The plugged USB 3.2 Gen 1 device may run on xHCI or EHCI mode depending on the operating system's setting.

6. USB 2.0 connectors (10-1 pin USB12; USB34)

These connectors are for USB 2.0 ports. Connect the USB module cable to any of these connectors, then install the module to a slot opening at the back of the system chassis. These USB connectors comply with USB 2.0 specification that supports up to 480 Mb/s connection speed.

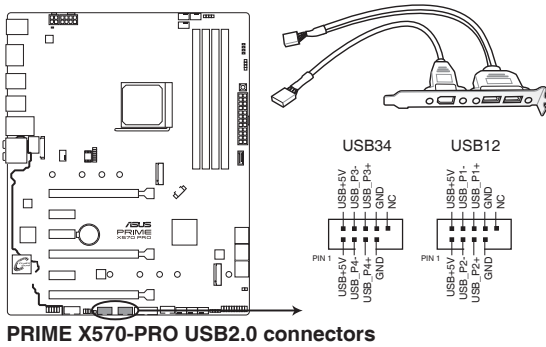

Never connect a 1394 cable to the USB connectors. Doing so will damage the motherboard!

7. Thermal sensor connector (2-pin T_SENSOR)

This connector is for the thermistor cable that allows you to monitor the temperature of your motherboard's critical components and connected devices.

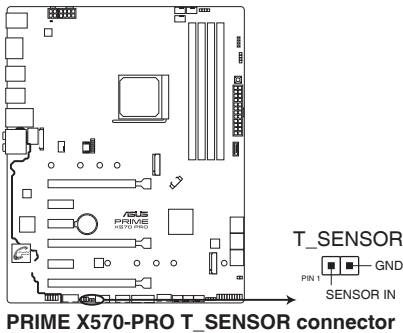

8. System panel connector (20-5 pin PANEL)

This connector supports several chassis-mounted functions.

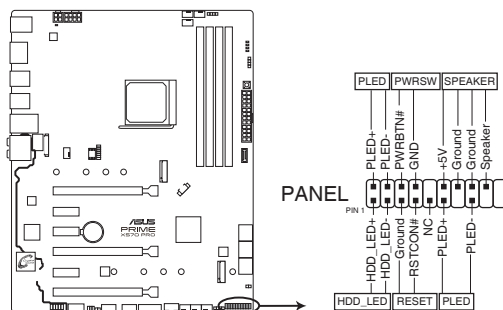

PRIME X570-PRO System panel connector

- **System power LED (2-pin or 3-1 pin PLED)**

The 2-pin or 3-1 pin connector is for the system power LED. Connect the chassis power LED cable to this connector. The system power LED lights up when you turn on the system power, and blinks when the system is in sleep mode.

- **Hard disk drive activity LED (2-pin HDD_LED)**

This 2-pin connector is for the HDD Activity LED. Connect the HDD Activity LED cable to this connector. The HDD LED lights up or flashes when data is read from or written to the HDD.

- **System warning speaker (4-pin SPEAKER)**

This 4-pin connector is for the chassis-mounted system warning speaker. The speaker allows you to hear system beeps and warnings.

- **ATX power button/soft-off button (2-pin PWRSW)**

This connector is for the system power button. Pressing the power button turns the system on or puts the system in sleep or soft-off mode depending on the operating system settings. Pressing the power switch for more than four seconds while the system is ON turns the system OFF.

- **Reset button (2-pin RESET)**

This 2-pin connector is for the chassis-mounted reset button for system reboot without turning off the system power.

9. CPU, CPU optional, and chassis fan connectors; water pump+, and AIO pump connectors (4-pin CPU_FAN, 4-pin CPU_OPT, 4-pin CHA_FAN1-3; 4-pin W_PUMP+, 4-pin AIO_PUMP)

Connect the fan cables to the fan connectors on the motherboard, ensuring that the black wire of each cable matches the ground pin of the connector.

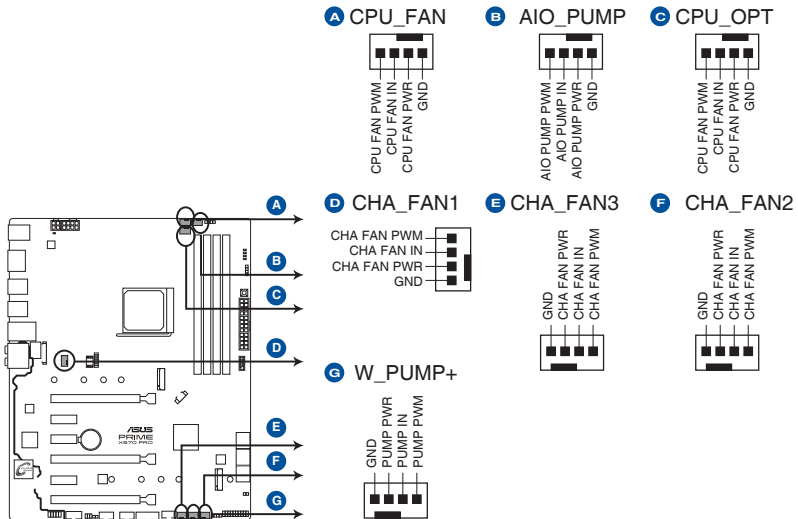

PRIME X570-PRO Fan connectors



- DO NOT forget to connect the fan cables to the fan connectors. Insufficient air flow inside the system may damage the motherboard components. These are not jumpers! Do not place jumper caps on the fan connectors!
- Ensure to fully insert the 4-pin CPU fan cable to the CPU fan connector.



- Connect the pump cable from the all-in-one cooler (AIO cooler) to the AIO_PUMP header, and connect the fan cables to the CPU_FAN and/or CPU_OPT header(s).
- W_PUMP+ function support depends on water cooling device.

Header	Max. Current	Max. Power	Default Speed	Shared Control
CPU_FAN	1A	12W	Q-Fan Controlled	A
CPU_OPT	1A	12W	Q-Fan Controlled	A
CHA_FAN1	1A	12W	Q-Fan Controlled	-
CHA_FAN2	1A	12W	Q-Fan Controlled	-
CHA_FAN3	1A	12W	Q-Fan Controlled	-
AIO_PUMP	1A	12W	Full Speed	B
W_PUMP+	3A	36W	Full Speed	B

10. ATX power connectors (24-pin EATXPWR; 8-pin EATX12V; 4-pin EATX12V)

These connectors are for ATX power supply plugs. The power supply plugs are designed to fit these connectors in only one orientation. Find the proper orientation and push down firmly until the connectors completely fit.

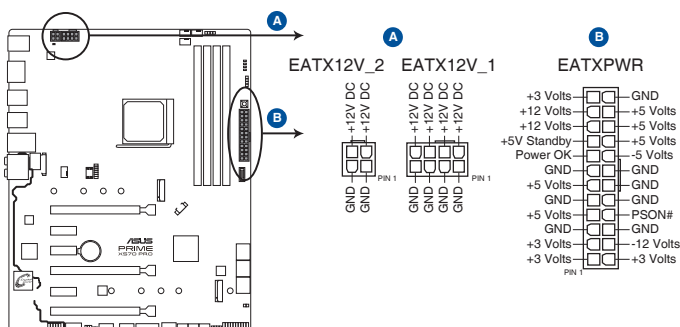

PRIME X570-PRO ATX power connectors



- DO NOT connect the 4-pin power plug only, the motherboard may overheat under heavy usage.
- Ensure to connect the 8-pin power plug, or both the 8-pin and 4-pin power plugs.



- For a fully configured system, we recommend that you use a power supply unit (PSU) that complies with ATX 12 V Specification 2.0 (or later version) and provides a minimum power of 350 W.
- We recommend that you use a PSU with a higher power output when configuring a system with more power-consuming devices. The system may become unstable or may not boot up if the power is inadequate.
- If you want to use two or more high-end PCIe x16 cards, use a PSU with 1000W power or above to ensure the system stability.

11. PCH fan header (4-pin PCH_FAN)

This PCH FAN header is for connecting PCH FAN under PCH cover.

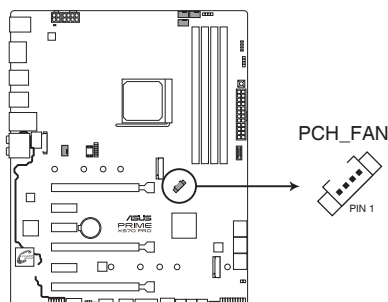

PRIME X570-PRO PCH FAN header

12. Serial port connector (10-1 pin COM)

This connector is for a serial (COM) port. Connect the serial port module cable to this connector, then install the module to a slot opening at the back of the system chassis.

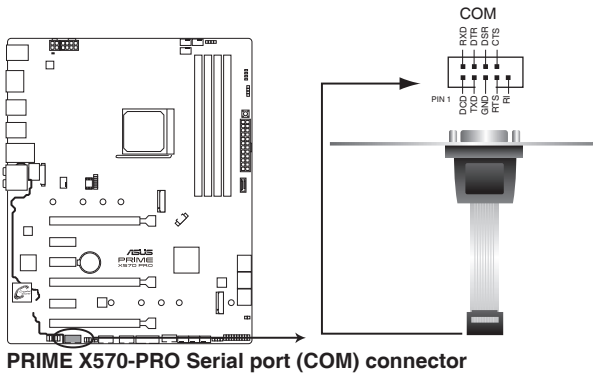

The COM module is purchased separately.

13. LED connector (13-pin LED1_CON)

The LED connector is for connecting an RGB Card under the rear I/O cover.

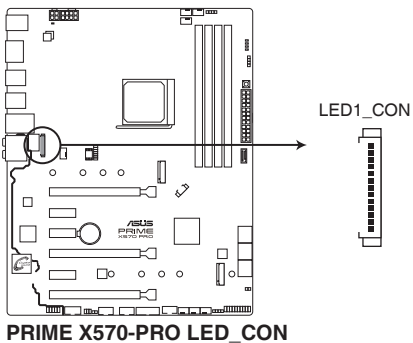

14. Node connector (12-1 pin NODE)

This connector allows you to connect a compatible PSU.

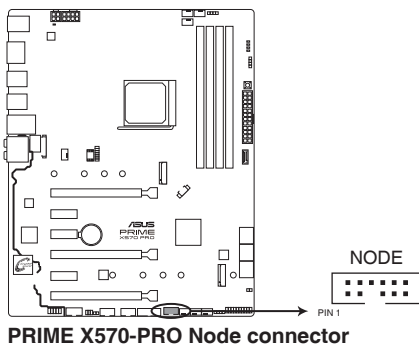

Visit <https://www.asus.com> for more information about the devices and latest compatibility list.

15. Power-on button (PWR_SW)

The motherboard comes with a power-on button that allows you to power up or wake up the system. The LED near the button also lights up when the system is plugged to a power source indicating that you should shut down the system and unplug the power cable before removing or installing any motherboard component.

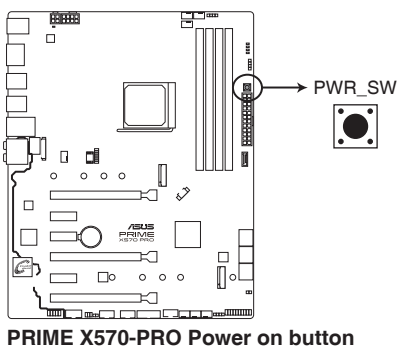

16. M.2 sockets (M.2_1; M.2_2)

These sockets allow you to install M.2 SSD modules.

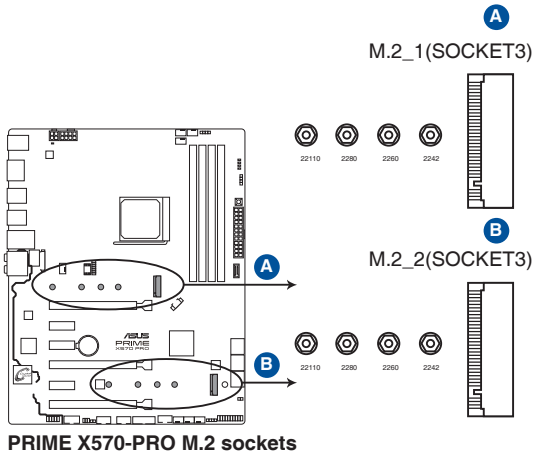

- For 3rd Gen AMD Ryzen™ Processors, the M.2_1 socket supports PCIe 4.0 x4 mode and SATA mode M Key design and type 2242 / 2260 / 2280 / 22110 storage devices.
- For 2nd Gen AMD Ryzen™/2nd and 1st Gen AMD Ryzen™ with Radeon™ Vega Graphics Processors, the M.2_1 socket supports PCIe 3.0 x4 mode and SATA mode M Key design and type 2242 / 2260 / 2280 / 22110 storage devices.
- The M.2_2 socket supports PCIe 4.0 x4 mode and SATA mode M Key design and type 2242 / 2260 / 2280 / 22110 storage devices.



The M.2 SSD module is purchased separately.

17. 8-pin Plug Power LED

The 8-pin Power Plug LED lights up to indicate that the 8-pin power plug is not connected.

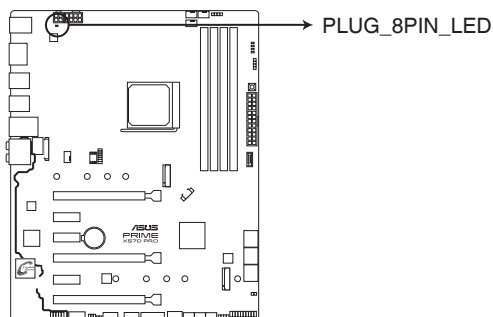

PRIME X570-PRO PLUG_8PIN_LED



-
- DO NOT connect the 4-pin power plug only, the motherboard may overheat under heavy usage.
 - Ensure to connect the 8-pin power plug, or both the 8-pin and 4-pin power plugs.
-

Basic Installation

2

2.1 Building your PC system



The diagrams in this section are for reference only. The motherboard layout may vary with models, but the installation steps are the same for all models.

2.1.1 CPU installation



The AMD AM4 socket is compatible with AMD AM4 processors. Ensure you use a CPU designed for the AM4 socket. The CPU fits in only one correct orientation. **DO NOT** force the CPU into the socket to prevent bending the connectors on the socket and damaging the CPU!

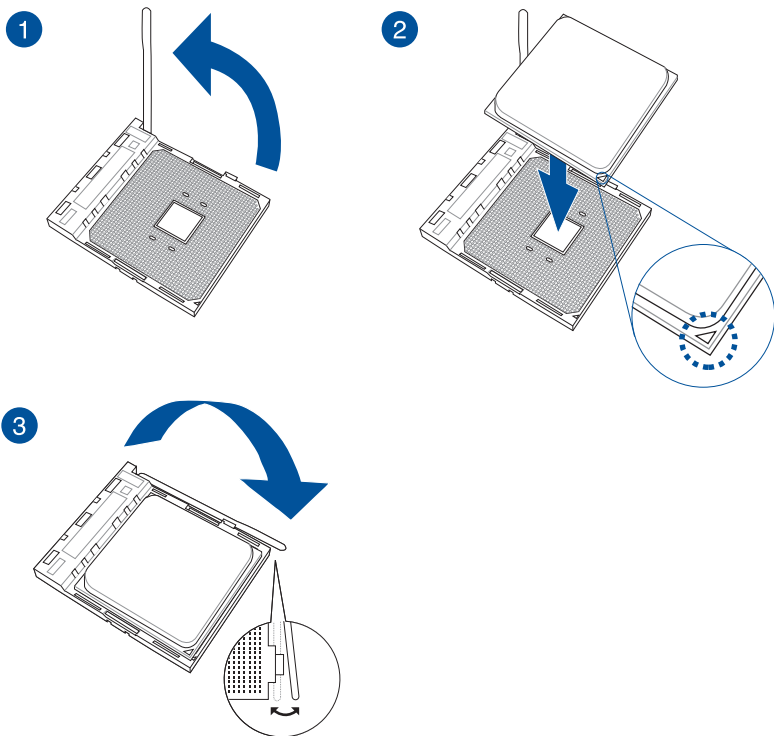

2.1.2 Cooling system installation



Apply the Thermal Interface Material to the CPU cooling system and CPU before you install the cooling system, if necessary.

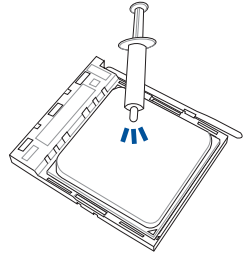

CPU heatsink and fan assembly Type 1

1

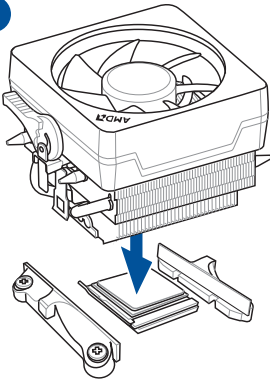

2

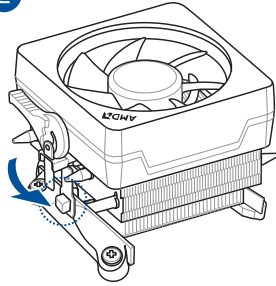

3

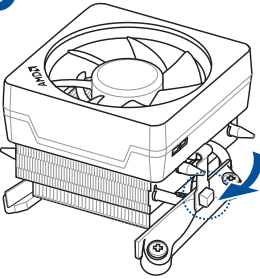

4

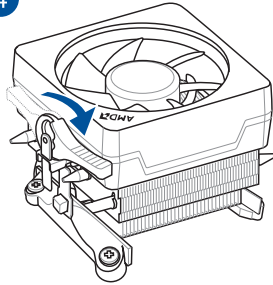

5

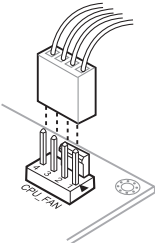

CPU heatsink and fan assembly Type 2

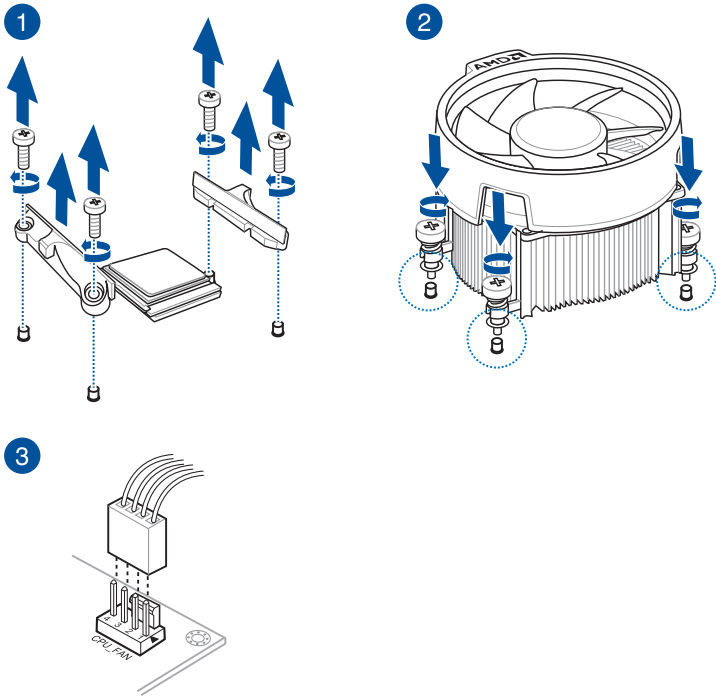

When using this type of CPU fan, remove the screws and the retention module only. Do not remove the plate on the bottom.

To install an AIO cooler

1

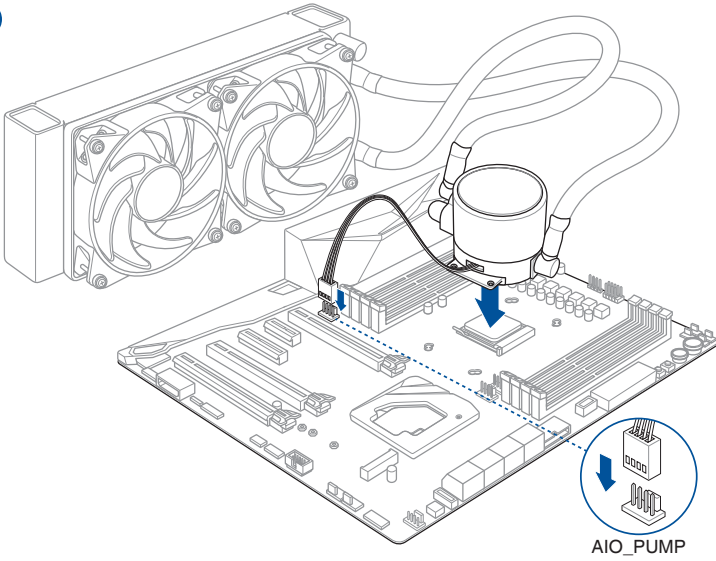

2

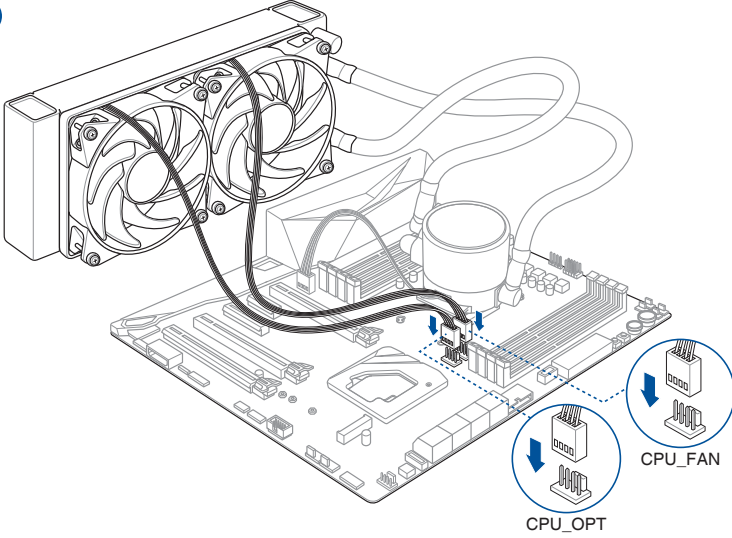

2.1.3 Motherboard installation

1. Place the motherboard into the chassis, ensuring that its rear I/O ports are aligned to the chassis' rear I/O panel.

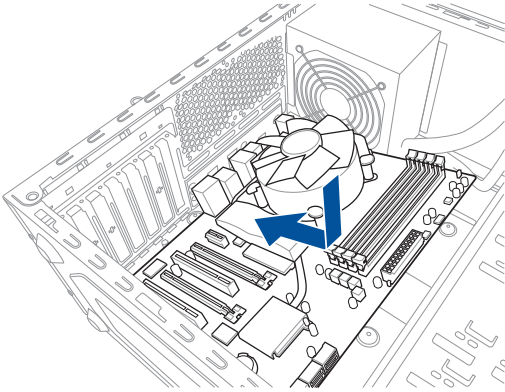

2. Place nine (9) screws into the holes indicated by circles to secure the motherboard to the chassis.

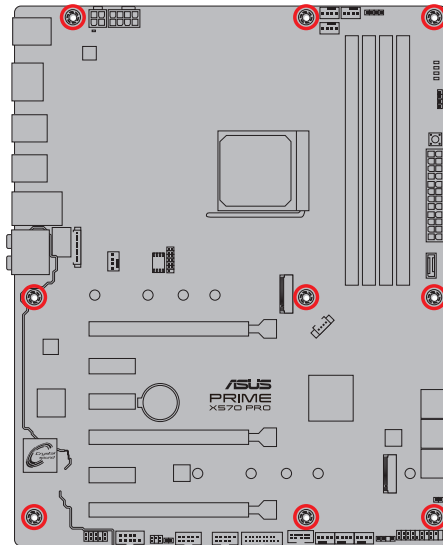
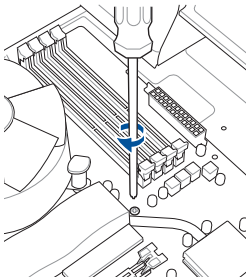

DO NOT over tighten the screws! Doing so can damage the motherboard.

2.1.4 DIMM installation

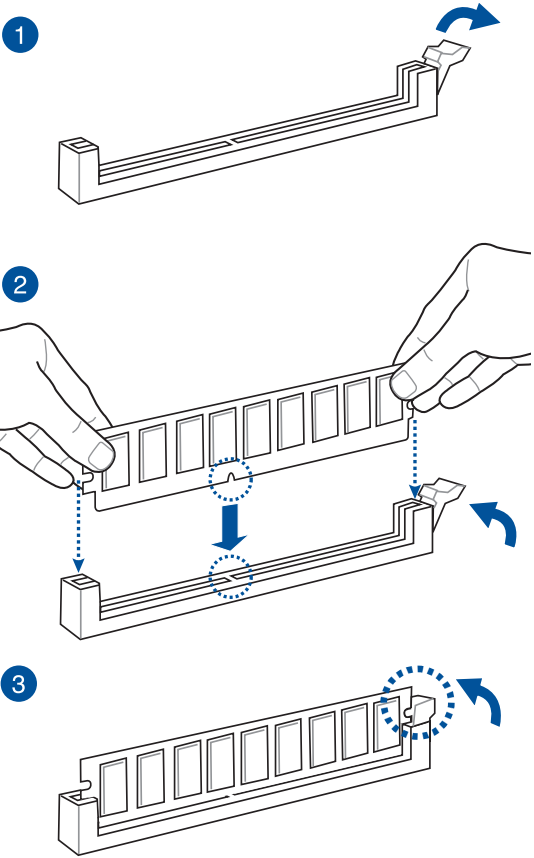

To remove a DIMM

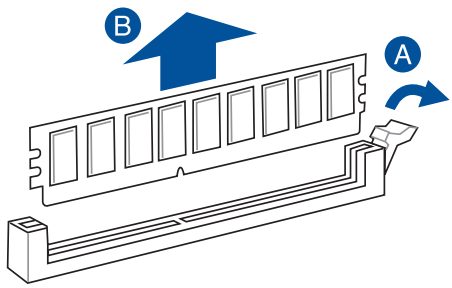

2.1.5 ATX power connection

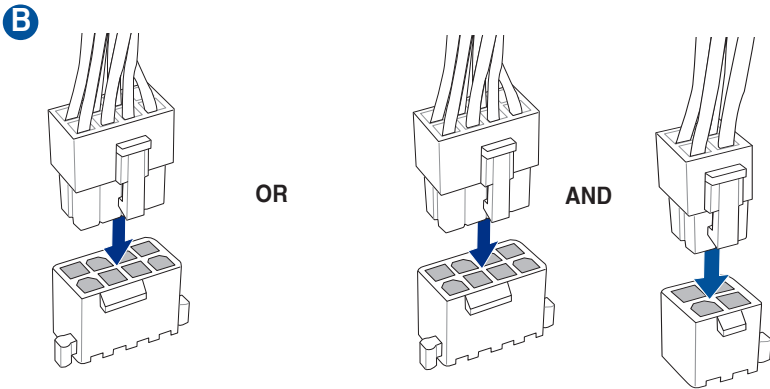
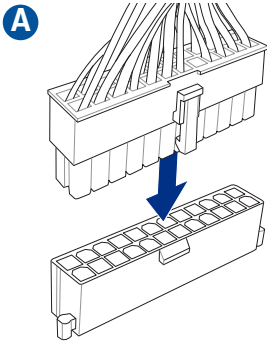

- DO NOT connect the 4-pin power plug only, the motherboard may overheat under heavy usage.
- Ensure to connect the 8-pin power plug, or both the 8-pin and 4-pin power plugs.

2.1.6 SATA device connection

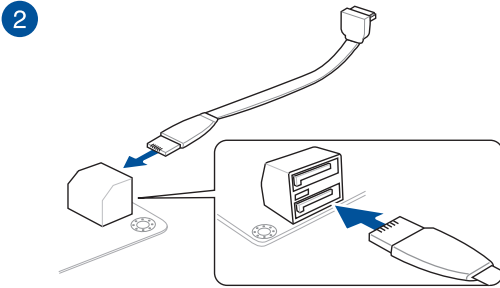
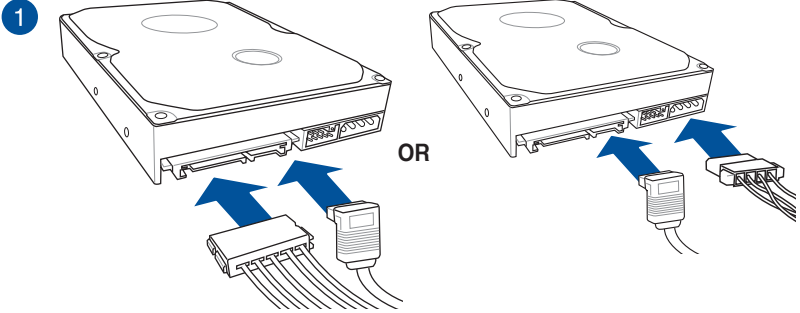

2.1.7 Front I/O connector

To install the front panel connector

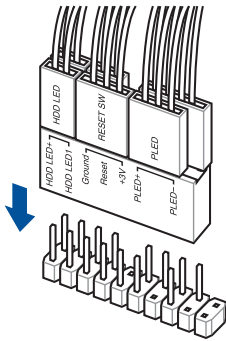

To install USB 3.2 Gen 2 connector

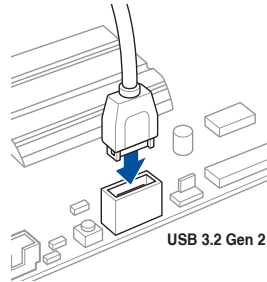

This connector will only fit in one orientation. Push the connector until it clicks into place.

To install USB 3.2 Gen 1 connector

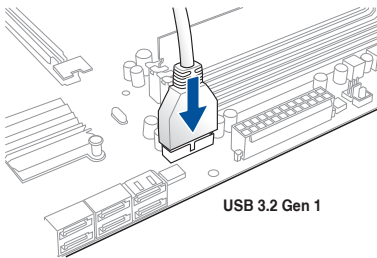

To install USB 2.0 connector

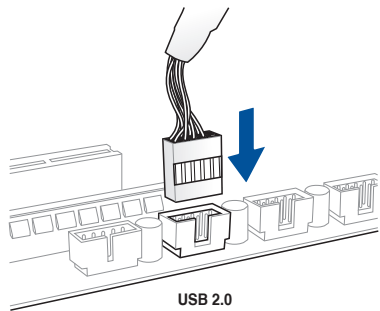

To install front panel audio connector

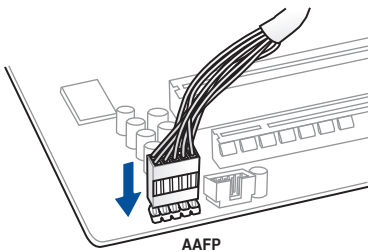

2.1.8 Expansion card installation

To install PCIe x16 cards

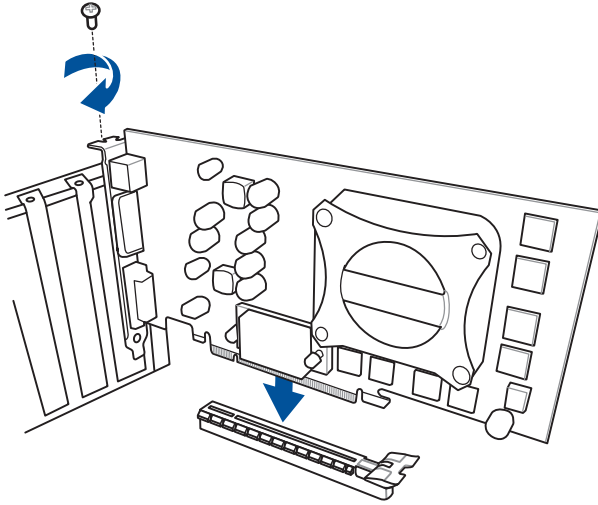

To install PCIe x1 cards

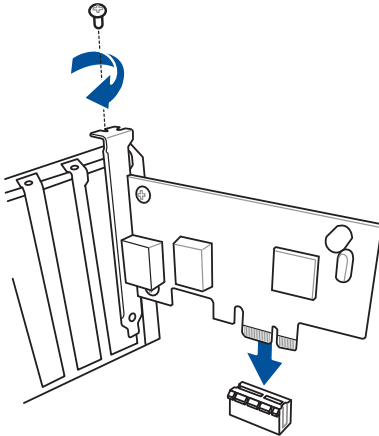

2.1.9 M.2 installation



Supported M.2 type varies per motherboard.

M.2_1 installation

1

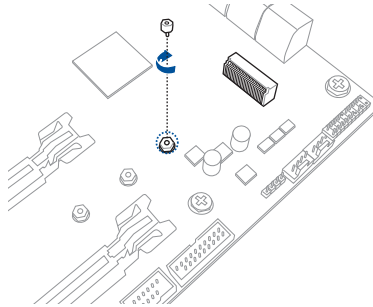

2

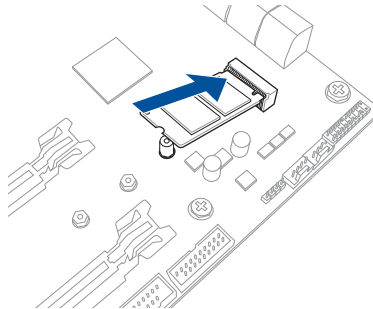

3

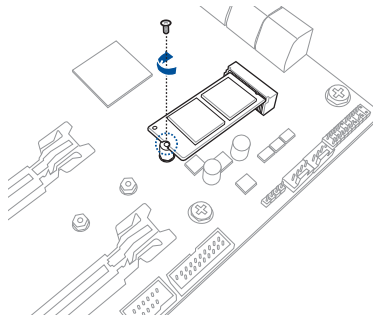

M.2_2 installation

1

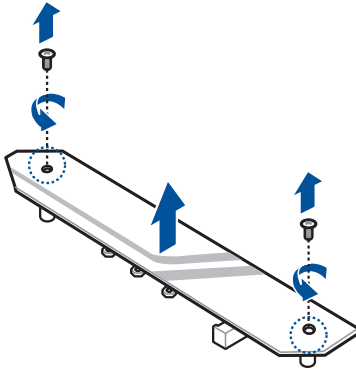

2

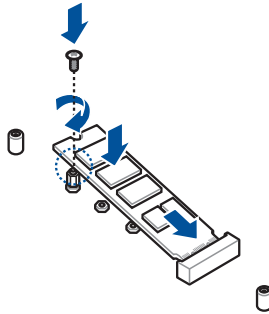

3

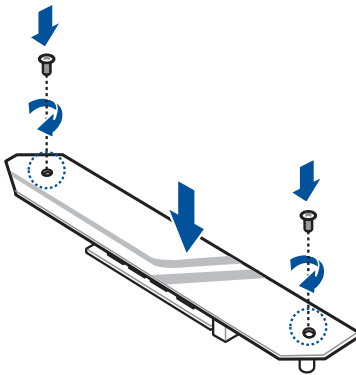

2.2 Motherboard rear and audio connections

2.2.1 Rear I/O connection

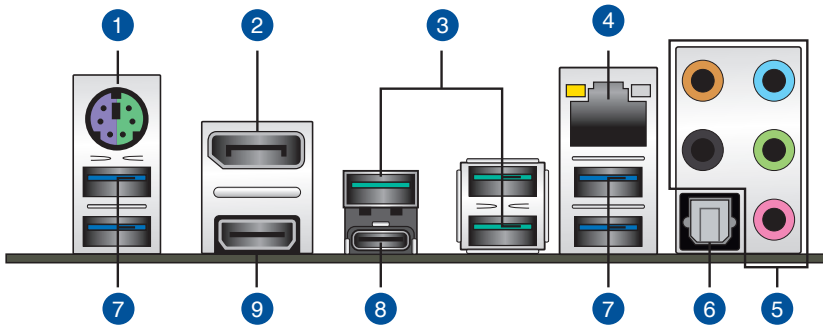

Rear panel connectors

- | | |
|----|--|
| 1. | PS/2 keyboard/ mouse combo port |
| 2. | DisplayPort |
| 3. | USB 3.2 Gen 2 (up to 10Gbps) ports |
| 4. | LAN (RJ-45) port* |
| 5. | Audio I/O ports** |
| 6. | Optical S/PDIF OUT port |
| 7. | USB 3.2 Gen 1 (up to 5Gbps) ports |
| 8. | USB 3.2 Gen 2 (up to 10Gbps) port (Type-C) |
| 9. | HDMI port |

* and **: Refer to the tables on the next page for LAN port LEDs, and audio port definitions.



- USB 3.2 Gen 2 / Gen 1 devices can only be used for data storage.
- Due to the design of AMD AM4 series chipset, all USB devices connected to the USB 3.2 Gen 1 / Gen 2 ports are controlled by the xHCI controller.
- We strongly recommend that you connect USB 3.2 Gen 2 devices to USB 3.2 Gen 2 ports for faster and better performance from your USB 3.2 Gen 2 devices.

*** LAN ports LED indications**

Activity Link LED		Speed LED	
Status	Description	Status	Description
Off	No link	Off	10 Mbps connection
Orange	Linked	Orange	100 Mbps connection
Orange (Blinking)	Data activity	Green	1 Gbps connection
Orange (Blinking then steady)	Ready to wake up from S5 mode		

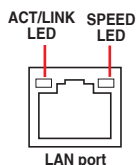

**** Audio 2, 4, 6 or 8-channel configuration**

Port	Headset 2-channel	4-channel	6-channel	8-channel
Light Blue	Line In	Line In	Line In	Side Speaker Out
Lime	Line Out	Front Speaker Out	Front Speaker Out	Front Speaker Out
Pink	Mic In	Mic In	Mic In	Mic In
Orange	–	–	Center/Sub woofer	Center/Sub woofer
Black	–	Rear Speaker Out	Rear Speaker Out	Rear Speaker Out

2.2.2 Audio I/O connections

Audio I/O ports

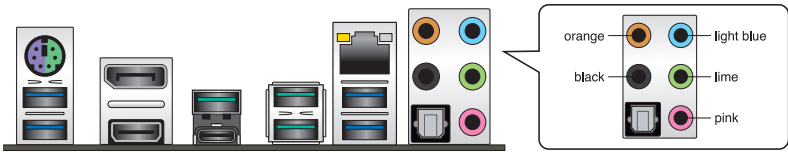

Connect to Headphone and Mic



Connect to Stereo Speakers

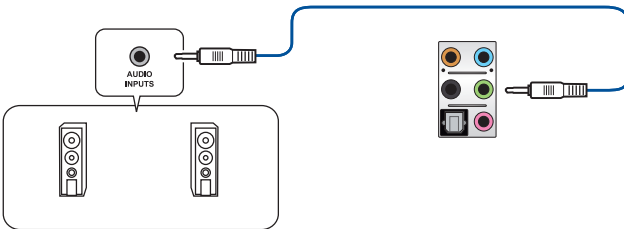

Connect to 2-channel Speakers

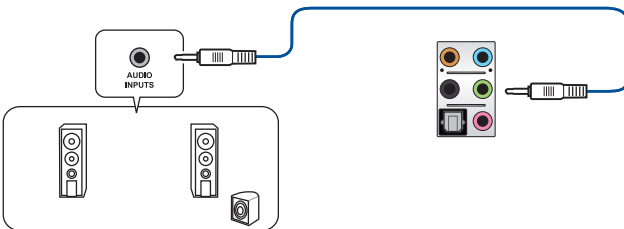

Connect to 4-channel Speakers

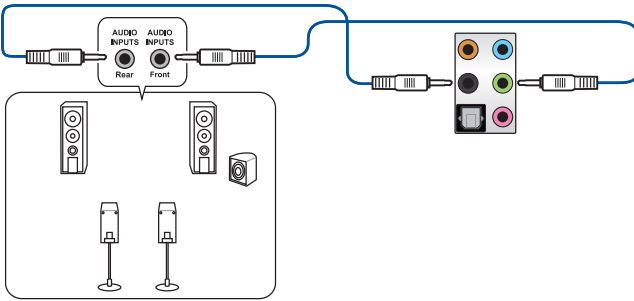

Connect to 6-channel Speakers

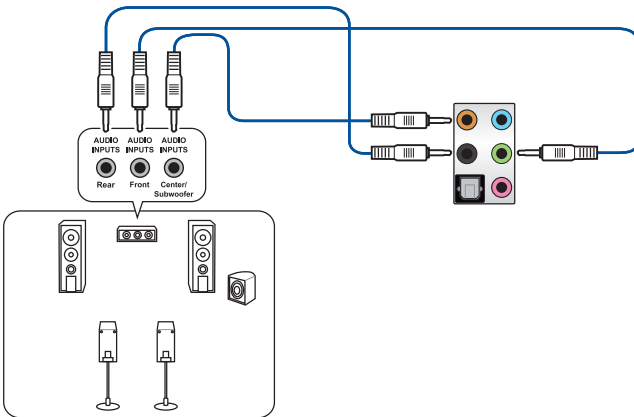

Connect to 8-channel Speakers

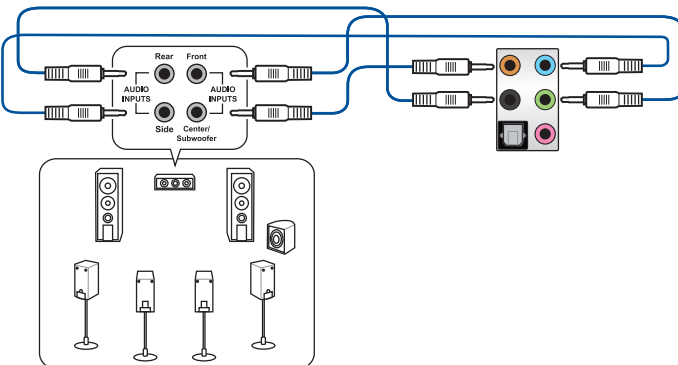

2.3 Starting up for the first time

1. After making all the connections, replace the system case cover.
2. Ensure that all switches are off.
3. Connect the power cord to the power connector at the back of the system chassis.
4. Connect the power cord to a power outlet that is equipped with a surge protector.
5. Turn on the devices in the following order:
 - a. Monitor
 - b. External SCSI devices (starting with the last device on the chain)
 - c. System power
6. After applying power, the system power LED on the system front panel case lights up. For systems with ATX power supplies, the system LED lights up when you press the ATX power button. If your monitor complies with the “green” standards or if it has a “power standby” feature, the monitor LED may light up or change from orange to green after the system LED turns on.

The system then runs the power-on self tests (POST). While the tests are running, the BIOS beeps (refer to the BIOS beep codes table) or additional messages appear on the screen. If you do not see anything within 30 seconds from the time you turned on the power, the system may have failed a power-on test. Check the jumper settings and connections or call your retailer for assistance.

BIOS Beep	Description
One short beep	VGA detected Quick boot set to disabled No keyboard detected
One continuous beep followed by two short beeps then a pause (repeated)	No memory detected
One continuous beep followed by three short beeps	No VGA detected
One continuous beep followed by four short beeps	Hardware component failure

7. At power on, hold down the <Delete> key to enter the BIOS Setup. Follow the instructions in Chapter 3.

2.4 Turning off the computer

While the system is ON, press the power button for less than four seconds to put the system on sleep mode or soft-off mode, depending on the BIOS setting. Press the power button for more than four seconds to let the system enter the soft-off mode regardless of the BIOS setting.

BIOS Setup

3

3.1 Knowing BIOS



The new ASUS UEFI BIOS is a Unified Extensible Interface that complies with UEFI architecture, offering a user-friendly interface that goes beyond the traditional keyboard-only BIOS controls to enable a more flexible and convenient mouse input. You can easily navigate the new UEFI BIOS with the same smoothness as your operating system. The term “BIOS” in this user manual refers to “UEFI BIOS” unless otherwise specified.

BIOS (Basic Input and Output System) stores system hardware settings such as storage device configuration, overclocking settings, advanced power management, and boot device configuration that are needed for system startup in the motherboard CMOS. In normal circumstances, the default BIOS settings apply to most conditions to ensure optimal performance. **DO NOT change the default BIOS settings** except in the following circumstances:

- An error message appears on the screen during the system bootup and requests you to run the BIOS Setup.
- You have installed a new system component that requires further BIOS settings or update.



Inappropriate BIOS settings may result to instability or boot failure. **We strongly recommend that you change the BIOS settings only with the help of a trained service personnel.**



- When downloading or updating the BIOS file, rename it as **PX570PRO.CAP** for this motherboard.
 - BIOS settings and options may vary due to different BIOS release versions. Please refer to the latest BIOS version for settings and options.
-

3.2 BIOS Setup program

Use the BIOS Setup to update the BIOS or configure its parameters. The BIOS screens include navigation keys and brief onscreen help to guide you in using the BIOS Setup program.

Entering BIOS at startup

To enter BIOS Setup at startup, press <Delete> or <F2> during the Power-On Self Test (POST). If you do not press <Delete> or <F2>, POST continues with its routines.

Entering BIOS Setup after POST

To enter BIOS Setup after POST:

- Press <Ctrl>+<Alt>+<Delete> simultaneously.
- Press the reset button on the system chassis.
- Press the power button to turn the system off then back on. Do this option only if you failed to enter BIOS Setup using the first two options.

After doing either of the three options, press <Delete> key to enter BIOS.



-
- The BIOS Setup screens shown in this section are for reference purposes only, and may not exactly match what you see on your screen.
 - Ensure that a USB mouse is connected to your motherboard if you want to use the mouse to control the BIOS Setup program.
 - If the system becomes unstable after changing any BIOS setting, load the default settings to ensure system compatibility and stability. Select the **Load Optimized Defaults** item under the **Exit** menu or press hotkey <F5>. See section 3.10 **Exit Menu** for details.
 - If the system fails to boot after changing any BIOS setting, try to clear the CMOS and reset the motherboard to the default value. See section 1.1.7 **Headers** for information on how to erase the RTC RAM via the Clear CMOS button.
 - The BIOS Setup program does not support the Bluetooth devices.
-



Please visit ASUS website for the detailed BIOS content manual.

BIOS menu screen

The BIOS Setup program can be used under two modes: **EZ Mode** and **Advanced Mode**. You can change modes from **Setup Mode** in **Boot menu** or by pressing the <F7> hotkey.

3.2.1 EZ Mode

By default, the EZ Mode screen appears when you enter the BIOS Setup program. The EZ Mode provides you an overview of the basic system information, and allows you to select the display language, system performance, mode and boot device priority. To access the Advanced Mode, select **Advanced Mode** or press the <F7> hotkey for the advanced BIOS settings.



The default screen for entering the BIOS Setup program can be changed. Refer to the **Setup Mode** item in section **Boot menu** for details.

Displays the CPU/motherboard temperature, CPU voltage output, CPU/chassis fan speed, and SATA information

Creates storage RAID and configures system overclocking

Displays the system properties of the selected mode. Click < or > to switch EZ System Tuning modes

Selects the display language of the BIOS Setup program

Searches by BIOS item name, enter the item name to find the related item listing

Turns the RGB LED lighting on or off

Displays the CPU Fan's speed. Click the button to manually tune the fans

Saves the changes and resets the system

Click to go to Advanced mode

Search on the FAQ

Loads optimized default settings

Click to display boot devices

Selects the boot device priority



The boot device options vary depending on the devices you installed to the system.

3.2.2 Advanced Mode

The Advanced Mode provides advanced options for experienced end-users to configure the BIOS settings. The figure below shows an example of the Advanced Mode. Refer to the following sections for the detailed configurations.



To switch from EZ Mode to Advanced Mode, click **Advanced Mode(F7)** or press the <F7> hotkey.

The screenshot shows the ASUS UEFI BIOS Utility in Advanced Mode. The interface is dark-themed with blue highlights. At the top, it displays the date and time (03/16/2019, 07:00) and the language (English). The main menu includes My Favorites, Main, Ai Tweaker, Advanced, Monitor, Boot, Tool, and Exit. The Ai Tweaker section is expanded, showing options like Memory Frequency, FCLK Frequency, CPU Core Ratio, EPU Power Saving Mode, TPU, Performance Bias, Precision Boost Overdrive, DRAM Timing Control, and DIGI+ VRM. The VDDCR CPU Voltage is set to 1.432V. The Hardware Monitor section on the right shows CPU frequency (3300 MHz), temperature (51°C), APU frequency (100.0 MHz), core voltage (1.424 V), ratio (33x), memory frequency (2400 MHz), and capacity (16384 MB). The bottom of the screen shows the last modified settings, a button to go back to EZ Mode (F7), hot keys (F7), and a search on FAQ option.

Menu items
Menu bar Language MyFavorite(F3) Qfan Control(F6) EZ Tuning Wizard(F11) Search(F9) Scroll bar AURA ON/OFF(F4)

Submenu items General help Configuration fields Pop-up Menu Last modified settings

Search on the FAQ Displays the CPU temperature, CPU, and memory voltage output

Go back to EZ Mode Hot Keys

Menu bar

The menu bar on top of the screen has the following main items:

My Favorites	For saving the frequently-used system settings and configuration.
Main	For changing the basic system configuration
Ai Tweaker	For changing the overclocking settings
Advanced	For changing the advanced system settings
Monitor	For displaying the system temperature, power status, and changing the fan settings.
Boot	For changing the system boot configuration
Tool	For configuring options for special functions
Exit	For selecting the exit options and loading default settings

Menu items

The highlighted item on the menu bar displays the specific items for that menu. For example, selecting **Main** shows the Main menu items.

The other items (My Favorites, Ai Tweaker, Advanced, Monitor, Boot, Tool, and Exit) on the menu bar have their respective menu items.

Submenu items

A greater than sign (>) before each item on any menu screen means that the item has a submenu. To display the submenu, select the item and press <Enter>.

Language

This button above the menu bar contains the languages that you can select for your BIOS. Click this button to select the language that you want to display in your BIOS screen.

My Favorites(F3)

This button above the menu bar shows all BIOS items in a Tree Map setup. Select frequently-used BIOS settings and save it to MyFavorites menu.



Refer to section **3.3 My Favorites** for more information.

Q-Fan Control(F6)

This button above the menu bar displays the current settings of your fans. Use this button to manually tweak the fans to your desired settings.



Refer to section **3.2.3 QFan Control** for more information.

Search (F9)

This button allows you to search by BIOS item name, enter the item name to find the related item listing.

EZ Tuning Wizard(F11)

This button above the menu bar allows you to view and tweak the overclocking settings of your system.



Refer to section 3.2.4 **EZ Tuning Wizard** for more information.

AURA (F4)

This button allows you to turn the RGB LED lighting on or off.

- [All On] All RGB LEDs and functional LEDs will be enabled. (Default mode)
- [Stealth] All LEDs will be disabled.
- [Aura Only] All RGB LEDs will be enabled, while functional LEDs will be disabled.
- [Aura Off] All RGB LEDs will be disabled, while functional LEDs will be enabled.

Search on FAQ

Move your mouse over this button to show a QR code, scan this QR code on your mobile device to connect to the BIOS FAQ web page of the ASUS support website. You can also scan the following QR code:



Hot keys

This button at the bottom of the screen contains the navigation keys for the BIOS Setup program. Use the navigation keys to select items in the menu and change the settings.

EZ Mode(F7)

This button at the bottom of the screen allows you to switch to Ez Mode.

Scroll bar

A scroll bar appears on the right side of a menu screen when there are items that do not fit on the screen. Press the Up/Down arrow keys or <Page Up> / <Page Down> keys to display the other items on the screen.

General help

At the bottom of the menu screen is a brief description of the selected item. Use <F12> key to capture the BIOS screen and save it to the removable storage device.

Configuration fields

These fields show the values for the menu items. If an item is user-configurable, you can change the value of the field opposite the item. You cannot select an item that is not user-configurable.

A configurable field is highlighted when selected. To change the value of a field, select it and press <Enter> to display a list of options.

Last Modified button

This button shows the items that you last modified and saved in BIOS Setup.

3.2.3 Q-Fan Control

The QFan Control allows you to set a fan profile or manually configure the operating speed of your CPU and chassis fans.

The screenshot shows the Q-Fan Control BIOS menu. At the top, it says "Q-Fan Control" and "Select your target fan and then move the slider to select any of these profiles: Standard, Silent, Turbo and Full Speed. You can also move the slider to Manual and manually configure the fan's operating speed." Below this is a graph with a y-axis labeled "%" (0 to 100) and an x-axis labeled "°C" (0 to 100). A yellow line shows a fan speed profile that is constant at 50% until 30°C, then rises to 100% at 70°C. Above the graph are "PWM" and "DC" mode buttons. Below the graph are radio buttons for "Standard", "Silent", "Turbo", "Full Speed", and "Manual". At the bottom are "Undo", "Apply", and "Exit (ESC)" buttons. A list of fan options is on the left: "Optimize All", "CPU FAN", "CHA1 FAN", "CHA2 FAN", "CHA3 FAN", "EXT FAN1", "EXT FAN2", "EXT FAN3", "EXT FAN4", "EXT FAN5", "EXT FAN6", "WATER PUMP+", and "ASUS Q-FAN".

Click to select a fan to be configured

Click to activate PWM Mode

Click to activate DC Mode

Select a profile to apply to your fans

Click to undo the changes

Click to apply the fan setting

Click to go back to main menu

Select to manually configure your fans

Configuring fans manually

Select **Manual** from the list of profiles to manually configure your fans' operating speed.

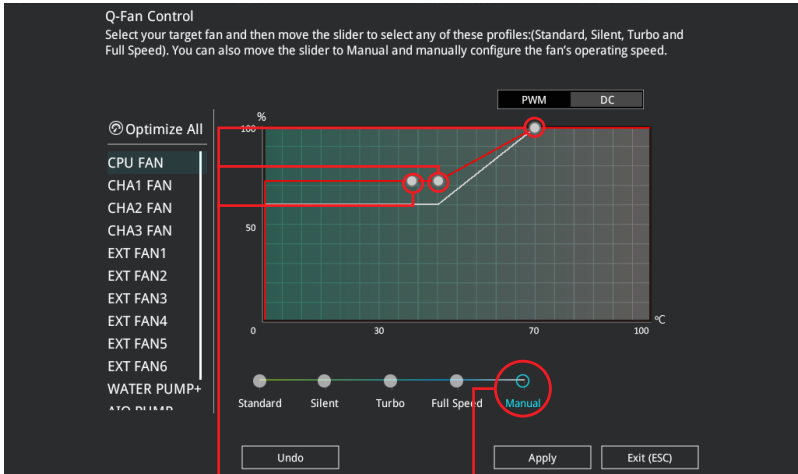

Speed points

Select to manually
configure your fans

To configure your fans:

1. Select the fan that you want to configure and to view its current status.
2. Click and drag the speed points to adjust the fans' operating speed.
3. Click **Apply** to save the changes then click **Exit (ESC)**.

3.2.4 EZ Tuning Wizard

EZ Tuning Wizard allows you to easily overclock your CPU and DRAM, computer usage, and CPU fan to their best settings.

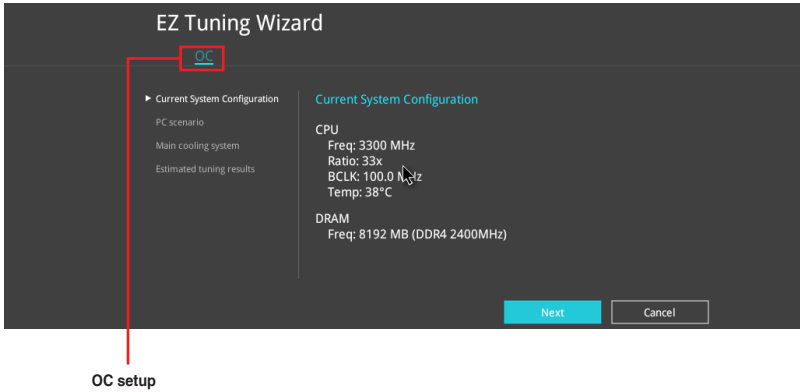

OC Tuning

To start OC Tuning:

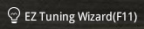
1. Press <F11> on your keyboard or click  from the BIOS screen to open EZ Tuning Wizard screen, and then click **Next**.
2. Select a PC scenario **Daily Computing** or **Gaming/Media Editing**, and then click **Next**.

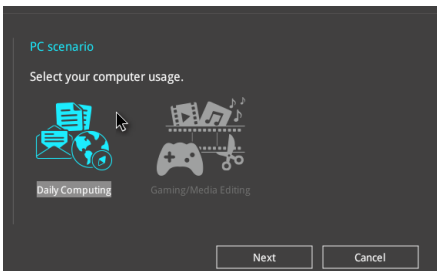

3. Select a Main Cooling System **BOX cooler**, **Tower cooler**, **Water cooler**, or **I'm not sure**, then click **Next**.

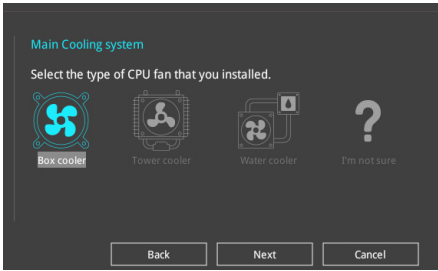

4. After selecting the Main Cooling System, click **Next** then click **Yes** to start the OC Tuning.

3.3 My Favorites

My Favorites is your personal space where you can easily save and access your favorite BIOS items.

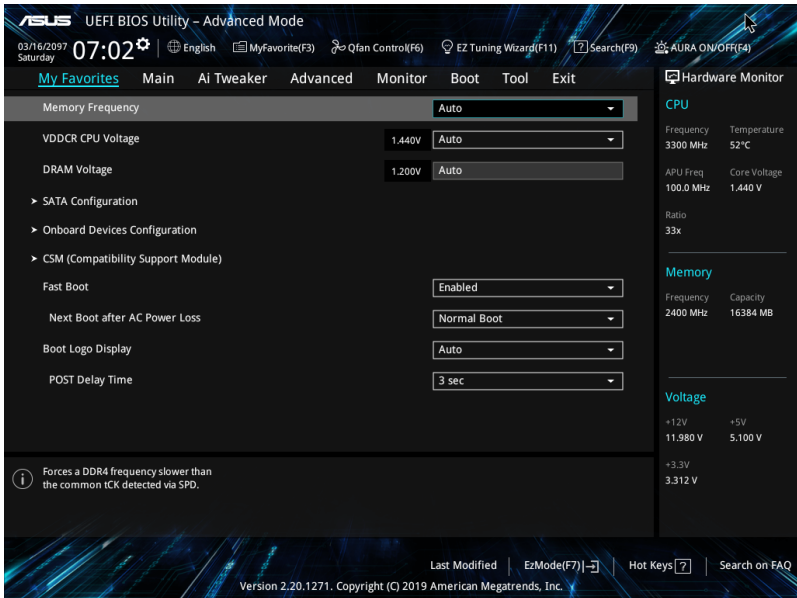



My Favorites comes with several performance, power saving, and fast boot related items by default. You can personalize this screen by adding or removing items.

Adding items to My Favorites

To add BIOS items:

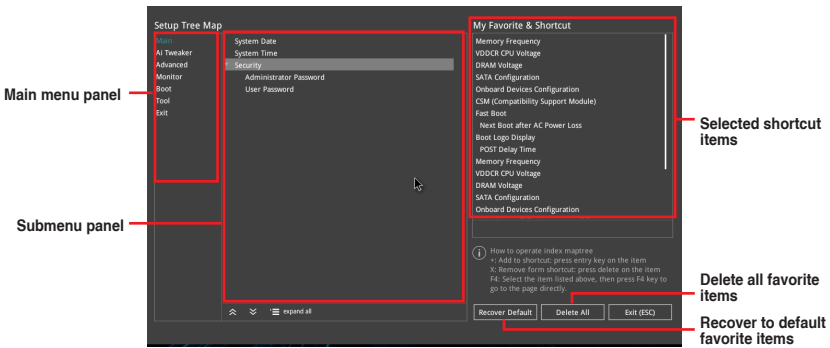
1. Press <F3> on your keyboard or click  (F3)/MyFavorite from the BIOS screen to open Setup Tree Map screen.
2. On the Setup Tree Map screen, select the BIOS items that you want to save in My Favorites screen.



3. Select an item from main menu panel, then click the submenu that you want to save as favorite from the submenu panel and click  or press <Enter> on your keyboard.



You cannot add user-managed items such as language and boot order to My Favorites.

4. Click **Exit (ESC)** or press <Esc> key to close Setup Tree Map screen.
5. Go to My Favorites menu to view the saved BIOS items.

3.4 Main menu

The Main menu screen appears when you enter the Advanced Mode of the BIOS Setup program. The Main menu provides you an overview of the basic system information, and allows you to set the system date, time, language, and security settings.

Security

The Security menu items allow you to change the system security settings.



- If you have forgotten your BIOS password, erase the CMOS Real Time Clock (RTC) RAM to clear the BIOS password. See section **1.1.7 Headers** for information on how to erase the RTC RAM via the Clear CMOS button.
- The Administrator or User Password items on top of the screen show the default **[Not Installed]**. After you set a password, these items show **[Installed]**.

3.5 Ai Tweaker menu

The Ai Tweaker menu items allow you to configure overclocking-related items.



Be cautious when changing the settings of the Ai Tweaker menu items. Incorrect field values can cause the system to malfunction



The configuration options for this section vary depending on the CPU and DIMM model you installed on the motherboard.

Memory Frequency

This item allows you to set the memory operating frequency. The configurable options vary with the BCLK (base clock) frequency setting. Select the auto mode to apply the optimized setting. Configuration options: [Auto] [DDR4-1333MHz] - [DDR4-5000MHz]



Selecting a very high memory frequency may cause the system to become unstable! If this happens, revert to the default setting.

EPU Power Saving Mode

The ASUS EPU (Energy Processing Unit) sets the CPU in its minimum power consumption settings. Enable this item to set lower CPU core/cache voltage and achieve the best energy saving condition. Configuration options: [Disabled] [Enabled]



The items in this menu may vary based on the CPU installed.

Custom CPU Core Ratio

Allows you to select the CPU core ratio to achieve the desired CPU internal frequency. Configuration options:

- | | |
|----------|---|
| [Auto] | Loads the optimal settings for the system. |
| [Manual] | Allows you to individually set the core ratio parameters. |



The items in this menu may vary based on the CPU installed.

TPU

This item allows you to automatically overclock the CPU and DRAM frequencies and voltage for an enhanced system performance.

- | | |
|-------------------------|--|
| [Keep Current Settings] | Keep the current settings without changing anything. |
| [TPU I] | Applies air cooling overclocking conditions. |
| [TPU II] | Applies water cooling overclocking conditions. |



Ensure to use water cooling device before selecting [TPU II].

Performance Bias

This item adjust settings to improve performance for different software.

Configuration options: [Auto] [None] [CB15] [Aida/Geekbench] [CB11.5]

3.6 Advanced menu

The Advanced menu items allow you to change the settings for the CPU and other system devices.



Be cautious when changing the settings of the Advanced menu items. Incorrect field values can cause the system to malfunction.

3.6.1 AMD fTPM Configuration

The items in this menu allow you to configure the AMD fTPM settings.

3.6.2 CPU Configuration

The items in this menu show the CPU-related information that the BIOS automatically detects.



The items in this menu may vary based on the CPU installed.

PSS Support

This item allows you enable or disable the generation of ACPI_PPC, _PSS, and _PCT objects.

Configuration options: [Disabled] [Enabled]

NX Mode

This item allows you enable or disable no-execute page protection function.

Configuration options: [Disabled] [Enabled]

SVM Mode

This item allows you enable or disable CPU Virtualization.

Configuration options: [Disabled] [Enabled]

SMT Mode

This item allows you enable or disable simultaneous multithreading.

Configuration options: [Disabled] [Auto]

Core Leveling Mode

This item allows you to change the number of compute unit in the system.

Configuration options: [Automatic mode] [One Computer Unit]

3.6.3 NB Configuration



NB Configuration function varies based on the CPU installed.

Primary Video Device

Selects the primary display device. Configuration options: [IGFX Video] [PCIE Video]

3.6.4 SATA Configuration

While entering Setup, the BIOS automatically detects the presence of SATA devices. The SATA Port items show **Empty** if no SATA device is installed to the corresponding SATA port.

SATA Port Enable

This item allows you to enable or disable the SATA Device. Configuration options: [Disabled] [Enabled]

SATA Mode

This item allows you to set the SATA configuration.

[AHCI] Set to [AHCI] when you want the SATA hard disk drives to use the AHCI (Advanced Host Controller Interface). The AHCI allows the onboard storage driver to enable advanced Serial ATA features that increases storage performance on random workloads by allowing the drive to internally optimize the order of commands.

[RAID] Set to [RAID] when you want to create a RAID configuration from the SATA hard disk drives.

NVMe RAID mode

This item allows you enable or disable the NVMe RAID mode. Configuration options: [Disabled] [Enabled]

SMART Self Test

S.M.A.R.T. (Self-Monitoring, Analysis and Reporting Technology) is a monitoring system that shows a warning message during POST (Power-on Self Test) when an error occurs in the hard disks. Configuration options: [On] [Off]

SATA6G_1~6 (Gray), M.2_1 (Gray), M.2_2 (Gray)

Select one item and click Enter to assign a new name for the item.

Hot Plug

These items allow you to enable/disable SATA Hot Plug Support. Configuration options: [Disabled] [Enabled]

3.6.5 Onboard Devices Configuration

The items in this menu allow you to switch between PCIe Lanes and configure onboard devices.

HD Audio Controller

This item allows you to use the Azalia High Definition Audio Controller. Configuration options: [Disabled] [Enabled]

PCIEX16_2 Bandwidth

This item displays varies based on the CPU installed.

[X8 Mode] The PCIe x16_2 slot runs at x8 mode.

[PCIe RAID Mode] The Hyper M.2 x16 card and other add-on M.2 devices all run at x4 mode, which allows you to create a PCIe RAID array.



Use PCIe RAID Mode when installing the Hyper M.2 x16 card or other M.2 adapter cards. Installing other devices when using PCIe RAID Mode may cause your PC to fail to boot up.

LED lighting

When system is in working state

This item allows you to turn the RGB LED lighting on or off when the system is in the working state. Configuration options: [All On] [Stealth Mode] [Aura Only] [Aura Off]

When system is in sleep, hibernate or soft off states

This item allows you to turn the RGB LED lighting on or off when the system is in the sleep, hibernate or soft off states. Configuration options: [All On] [Stealth Mode] [Aura Only] [Aura Off]

Intel LAN Controller

Enables or disables the Intel LAN controllers. Configuration options: [On] [Off]

Intel LAN OPROM

Enables or disables the Intel PXE OPROM. Configuration options: [On] [Off]

USB power delivery in Soft Off state S5

This item allows you to charge USB devices even when the system is in Soft Off state S5. Configuration options: [Disabled] [Enabled]

3.6.6 APM Configuration

The items in this menu allow you to set system wake and sleep settings.

ErP Ready [Disabled]

This item allows you to switch off some power at S4+S5 or S5 to get the system ready for ErP requirement. When set to **[Enabled]**, all other PME options are switched off. Configuration options: [Disabled] [Enable(S4+S5)] [Enable(S5)]

Restore On AC Power Loss

This item allows your system to go to ON state, OFF state, or both states after an AC power loss. When setting your system to [Last State], it goes to the previous state before the AC power loss. Configuration options: [Power Off] [Power On] [Last State]

Power On By PS/2 Keyboard

This item allows you to enable or disable to generate a wake event by pressing the configured key. Configuration options: [Disabled] [Space Bar] [Ctrl-Esc] [Power Key]

Power On By PCI-E

This item allows you to enable or disable the Wake-on-LAN function of the onboard LAN controller or other installed PCI-E LAN cards. Configuration options: [Disabled] [Enabled]

Power On By RTC

This item allows you to enable or disable the RTC (Real-Time Clock) to generate a wake event and configure the RTC alarm date. When enabled, you can set the days, hours, minutes, or seconds to schedule an RTC alarm date. Configuration options: [Disabled] [Enabled]

3.6.7 PCI Subsystem Settings

SR-IOV Support

This item allows you to enable or disable the Single Root IO Virtualization support if your system has SR-IOV capable PCIe devices.

3.6.8 USB Configuration

The items in this menu allow you to change the USB-related features.



The **Mass Storage Devices** item shows the auto-detected values. If no USB device is detected, the item shows **None**.

Legacy USB Support

This item allows you to enable or disable support for legacy USB devices. Configuration options: [Enabled] [Disabled] [Auto]

USB Single Port Control

This item allows you to enable or disable the individual USB ports.



Refer to section 1.1.2 **Motherboard layout** for the location of the USB ports.

3.6.9 HDD/SSD SMART Information

This menu displays the SMART information of the connected devices.



NVM Express devices do not support SMART information.

3.6.10 Network Stack Configuration

The items in this menu allow you to enable or disable the UEFI network stack

3.7 Monitor menu

The Monitor menu displays the system temperature/power status, and allows you to change the fan settings.

3.7.1 Q-Fan Configuration

The subitems in this menu allow you to configure the Q-Fan features.

Qfan Tuning

Click this item to automatically detect the lowest speed and configure the minimum duty cycle for each fan.

Chassis Fan(s) Configuration

Configure chassis fan(s) detailed settings of individual fans including: profile, duty, temperature and more.

3.8 Boot menu

The Boot menu items allow you to change the system boot options.

3.8.1 Boot Configuration

Fast Boot

- | | |
|------------|---|
| [Disabled] | Allows your system to go back to its normal boot speed. |
| [Enabled] | Allows your system to accelerate the boot speed. |



The following items appear only when you set the Fast Boot to **[Enabled]**.

Next Boot after AC Power Loss

- | | |
|---------------|---|
| [Normal Boot] | Returns to normal boot on the next boot after an AC power loss. |
| [Fast Boot] | Accelerates the boot speed on the next boot after an AC power loss. |

Setup Mode

- | | |
|-----------------|---|
| [Advanced Mode] | This item allows you to go to Advanced Mode of the BIOS after POST. |
| [EZ Mode] | This item allows you to go to EZ Mode of the BIOS after POST. |

3.8.2 CSM (Compatibility Support Module)

This item allows you to configure the CSM (Compatibility Support Module) items to fully support the various VGA, bootable devices and add-on devices for better compatibility.

3.8.3 Secure Boot

This item allows you to configure the Windows Secure Boot settings and manage its keys to protect the system from unauthorized access and malwares during POST.

Boot Option Priorities

These items specify the boot device priority sequence from the available devices. The number of device items that appears on the screen depends on the number of devices installed in the system.



- To access Windows OS in Safe Mode, press <F8> after POST.
- To select the boot device during system startup, press <F8> when the ASUS Logo appears.

Boot Override

These items displays the available devices. The number of device items that appears on the screen depends on the number of devices installed in the system. Click an item to start booting from the selected device.

3.9 Tool menu

The Tool menu items allow you to configure options for special functions. Select an item then press <Enter> to display the submenu.

3.9.1 ASUS EZ Flash 3 Utility

This item allows you to run ASUS EZ Flash 3. When you press <Enter>, a confirmation message appears. Use the left/right arrow key to select between [Yes] or [No], then press <Enter> to confirm your choice.



For more details, refer to section **3.11.2 ASUS EZ Flash 3**.

3.9.2 ASUS User Profile

This item allows you to store or load multiple BIOS settings.

Load from Profile

This item allows you to load the previous BIOS settings saved in the BIOS Flash. Key in the profile number that saved your BIOS settings, press <Enter>, and then select **Yes**.



- DO NOT shut down or reset the system while updating the BIOS to prevent the system boot failure!
- We recommend that you update the BIOS file only coming from the same memory/ CPU configuration and BIOS version.

Profile Name

This item allows you to key in a profile name.

Save to Profile

This item allows you to save the current BIOS settings to the BIOS Flash, and create a profile. Key in a profile number from one to eight, press <Enter>, and then select **Yes**.

Load/Save Profile from/to USB Drive

This item allows you to load or save profile from your USB drive, load and save profile to your USB drive.

3.9.3 ASUS SPD Information

This item allows you to view the DRAM SPD information.

3.9.4 Graphics Card Information

This item displays the information about the graphics card installed in your system.

GPU Post

This item displays the information and recommended configuration for the PCIE slots that the graphics card is installed in your system.



This feature is only supported on selected ASUS graphics cards.

3.9.5 ASUS Armoury Crate

This item allows you to download and install the ASUS ARMOURY CRATE app.

3.10 Exit menu

The Exit menu items allow you to load the optimal default values for the BIOS items, and save or discard your changes to the BIOS items. You can access the EZ Mode from the Exit menu.

Load Optimized Defaults

This option allows you to load the default values for each of the parameters on the Setup menus. When you select this option or if you press <F5>, a confirmation window appears. Select **OK** to load the default values.

Save Changes & Reset

Once you are finished making your selections, choose this option from the Exit menu to ensure the values you selected are saved. When you select this option or if you press <F10>, a confirmation window appears. Select **OK** to save changes and exit.

Discard Changes & Exit

This option allows you to exit the Setup program without saving your changes. When you select this option or if you press <Esc>, a confirmation window appears. Select **Yes** to discard changes and exit.

Launch EFI Shell from USB drives

This item allows you to attempt to launch the EFI Shell application (shellx64.efi) from one of the available filesystem devices.

3.11 Updating BIOS

The ASUS website publishes the latest BIOS versions to provide enhancements on system stability, compatibility, and performance. However, BIOS updating is potentially risky. If there is no problem using the current version of BIOS, DO NOT manually update the BIOS. Inappropriate BIOS updating may result to system's failure to boot. Carefully follow the instructions in this chapter to update your BIOS when necessary.



Visit <http://www.asus.com> to download the latest BIOS file for this motherboard.

The following utilities allow you to manage and update the motherboard BIOS Setup program.

1. EZ Update: Updates the BIOS in Windows environment.
2. ASUS EZ Flash 3: Updates the BIOS using a USB flash drive.
3. ASUS CrashFree BIOS 3: Restores the BIOS using the motherboard support DVD or a USB flash drive when the BIOS file fails or gets corrupted.

3.11.1 EZ Update

The EZ Update is a utility that allows you to update the motherboard BIOS in Windows environment.



-
- EZ Update requires an Internet connection either through a network or an ISP (Internet Service Provider).
 - This utility is available in the support DVD that comes with the motherboard package.
-

3.11.2 ASUS EZ Flash 3

The ASUS EZ Flash 3 feature allows you to update to the BIOS without using an OS-based utility.



Ensure to load the BIOS default settings to ensure system compatibility and stability. Select the **Load Optimized Defaults** item under the **Exit** menu. See section **3.10 Exit Menu** for details.

To update the BIOS:



-
- This function can support devices such as a USB flash disk with FAT 32/16 format and single partition only.
 - DO NOT shut down or reset the system while updating the BIOS to prevent system boot failure!
-

1. Insert the USB flash disk that contains the latest BIOS file to the USB port.
2. Enter the Advanced Mode of the BIOS Setup program. Go to the **Tool** menu to select **ASUS EZ Flash 3 Utility** and press <Enter>.
3. Press <Tab> to switch to the **Drive** field.
4. Press the Up/Down arrow keys to find the USB flash disk that contains the latest BIOS, and then press <Enter>.
5. Press <Tab> to switch to the **Folder** field.
6. Press the Up/Down arrow keys to find the BIOS file, and then press <Enter> to perform the BIOS update process. Reboot the system when the update process is done.

3.11.3 ASUS CrashFree BIOS 3

The ASUS CrashFree BIOS 3 utility is an auto recovery tool that allows you to restore the BIOS file when it fails or gets corrupted during the updating process. You can restore a corrupted BIOS file using the motherboard support DVD or a USB flash drive that contains the BIOS file.



The BIOS file in the motherboard support DVD may be older than the BIOS file published on the ASUS official website. If you want to use the newer BIOS file, download the file at <https://www.asus.com/support/> and save it to a USB flash drive.

Recovering the BIOS

To recover the BIOS:

1. Turn on the system.
2. Insert the motherboard support DVD to the optical drive, or the USB flash drive containing the BIOS file to the USB port.
3. The utility automatically checks the devices for the BIOS file. When found, the utility reads the BIOS file and enters ASUS EZ Flash 3 automatically.
4. The system requires you to enter BIOS Setup to recover the BIOS setting. To ensure system compatibility and stability, we recommend that you press <F5> to load default BIOS values.



DO NOT shut down or reset the system while updating the BIOS! Doing so can cause system boot failure!

Appendix

Notices

FCC Compliance Information

Responsible Party: Asus Computer International
Address: 48720 Kato Rd., Fremont, CA 94538, USA
Phone / Fax No: (510)739-3777 / (510)608-4555

This device complies with part 15 of the FCC Rules. Operation is subject to the following two conditions: (1) This device may not cause harmful interference, and (2) this device must accept any interference received, including interference that may cause undesired operation.

This equipment has been tested and found to comply with the limits for a Class B digital device, pursuant to part 15 of the FCC Rules. These limits are designed to provide reasonable protection against harmful interference in a residential installation. This equipment generates, uses and can radiate radio frequency energy and, if not installed and used in accordance with the instructions, may cause harmful interference to radio communications. However, there is no guarantee that interference will not occur in a particular installation. If this equipment does cause harmful interference to radio or television reception, which can be determined by turning the equipment off and on, the user is encouraged to try to correct the interference by one or more of the following measures:

- Reorient or relocate the receiving antenna.
- Increase the separation between the equipment and receiver.
- Connect the equipment into an outlet on a circuit different from that to which the receiver is connected.
- Consult the dealer or an experienced radio/TV technician for help.

Compliance Statement of Innovation, Science and Economic Development Canada (ISED)

This device complies with Innovation, Science and Economic Development Canada licence exempt RSS standard(s). Operation is subject to the following two conditions: (1) this device may not cause interference, and (2) this device must accept any interference, including interference that may cause undesired operation of the device.

CAN ICES-3(B)/NMB-3(B)

Déclaration de conformité de Innovation, Sciences et Développement économique Canada (ISED)

Le présent appareil est conforme aux CNR d'Innovation, Sciences et Développement économique Canada applicables aux appareils radio exempts de licence. L'exploitation est autorisée aux deux conditions suivantes : (1) l'appareil ne doit pas produire de brouillage, et (2) l'utilisateur de l'appareil doit accepter tout brouillage radioélectrique subi, même si le brouillage est susceptible d'en compromettre le fonctionnement.

CAN ICES-3(B)/NMB-3(B)

VCCI: Japan Compliance Statement

Class B ITE

この装置は、クラスB情報技術装置です。この装置は、家庭環境で使用することを目的としていますが、この装置がラジオやテレビジョン受信機に近接して使用されると、受信障害を引き起こすことがあります。

取扱説明書に従って正しい取り扱いをして下さい。

VCCI-B

Japan JATE

本製品は電気通信事業者(移動通信会社、固定通信会社、インターネットプロバイダ等)の通信回線(公衆無線LANを含む)に直接接続することができません。本製品をインターネットに接続する場合は、必ずルーター等を経由して接続してください。

KC: Korea Warning Statement

B급 기기 (가정용 방송통신기자재)

이 기기는 가정용(B급) 전자파적합기기로서 주로 가정에서 사용하는 것을 목적으로 하며, 모든 지역에서 사용할 수 있습니다.

*당해 무선설비는 전파혼신 가능성이 있으므로 인명안전과 관련된 서비스는 할 수 없습니다.

REACH

Complying with the REACH (Registration, Evaluation, Authorisation, and Restriction of Chemicals) regulatory framework, we published the chemical substances in our products at ASUS REACH website at <http://csr.asus.com/english/REACH.htm>.



DO NOT throw the motherboard in municipal waste. This product has been designed to enable proper reuse of parts and recycling. This symbol of the crossed out wheeled bin indicates that the product (electrical and electronic equipment) should not be placed in municipal waste. Check local regulations for disposal of electronic products.



DO NOT throw the mercury-containing button cell battery in municipal waste. This symbol of the crossed out wheeled bin indicates that the battery should not be placed in municipal waste.

ASUS Recycling/Takeback Services

ASUS recycling and takeback programs come from our commitment to the highest standards for protecting our environment. We believe in providing solutions for you to be able to responsibly recycle our products, batteries, other components as well as the packaging materials. Please go to <http://csr.asus.com/english/Takeback.htm> for detailed recycling information in different regions.

Regional notice for California



WARNING

Cancer and Reproductive Harm -
www.P65Warnings.ca.gov

Google™ License Terms

Copyright© 2020 Google Inc. All Rights Reserved.

Licensed under the Apache License, Version 2.0 (the “License”); you may not use this file except in compliance with the License. You may obtain a copy of the License at:

<http://www.apache.org/licenses/LICENSE-2.0>

Unless required by applicable law or agreed to in writing, software distributed under the License is distributed on an “AS IS” BASIS, WITHOUT WARRANTIES OR CONDITIONS OF ANY KIND, either express or implied.

See the License for the specific language governing permissions and limitations under the License.

English ASUSTeK Computer Inc. hereby declares that this device is in compliance with the essential requirements and other relevant provisions of related Directives. Full text of EU declaration of conformity is available at: www.asus.com/support

Français AsusTek Computer Inc. déclare par la présente que cet appareil est conforme aux critères essentiels et autres clauses pertinentes des directives concernées. La déclaration de conformité de l'UE peut être téléchargée à partir du site Internet suivant: www.asus.com/support

Deutsch ASUSTeK Computer Inc. erklärt hiermit, dass dieses Gerät mit den wesentlichen Anforderungen und anderen relevanten Bestimmungen der zugehörigen Richtlinien übereinstimmt. Der gesamte Text der EU-Konformitätserklärung ist verfügbar unter: www.asus.com/support

Italiano ASUSTeK Computer Inc. con la presente dichiara che questo dispositivo è conforme ai requisiti essenziali e alle altre disposizioni pertinenti con le direttive correlate. Il testo completo della dichiarazione di conformità UE è disponibile all'indirizzo: www.asus.com/support

Русский Компания ASUS заявляет, что это устройство соответствует основным требованиям и другим соответствующим условиям соответствующих директив. Подробную информацию, пожалуйста, смотрите на www.asus.com/support

Български С настоящото ASUSTeK Computer Inc. декларира, че това устройство е в съответствие със съществените изисквания и другите приложими постановления на свързаните директиви. Пълният текст на декларацията за съответствие на ЕС е достъпен на адрес: www.asus.com/support

Hrvatski ASUSTeK Computer Inc. ovim izjavljuje da je ovaj uređaj sukladan s bitnim zahtjevima i ostalim odgovarajućim odredbama vezanih direktiva. Cijeli tekst EU izjave o sukladnosti dostupan je na: www.asus.com/support

Čeština Společnost ASUSTeK Computer Inc. tímto prohlašuje, že toto zařízení splňuje základní požadavky a další příslušná ustanovení souvisejících směrnic. Plné znění prohlášení o shodě EU je k dispozici na adrese: www.asus.com/support

Dansk ASUSTeK Computer Inc. erklærer hermed, at denne enhed er i overensstemmelse med hovedkravene og andre relevante bestemmelser i de relaterede direktiver. Hele EU-overensstemmelseserklæringen kan findes på: www.asus.com/support

Nederlands ASUSTeK Computer Inc. verklaart hierbij dat dit apparaat voldoet aan de essentiële vereisten en andere relevante bepalingen van de verwante richtlijnen. De volledige tekst van de EU-verklaring van conformiteit is beschikbaar op: www.asus.com/support

Eesti Käesolevaga kinnitab ASUSTeK Computer Inc, et see seade vastab asjakohaste direktiivide olulistele nõuetele ja teisteles asjassepuutuvatele sätetele. El vastavusdeklaratsiooni täielik tekst on saadaval järgmisel aadressil: www.asus.com/support

Suomi ASUSTeK Computer Inc. ilmoittaa täten, että tämä laite on asiaankuuluvien direktiivien olennaisten vaatimusten ja muiden tätä koskevien säädösten mukainen. EU-yhdenmukaisuusilmoituksen koko teksti on luettavissa osoitteessa: www.asus.com/support

Ελληνικά Με το παρόν, η ASUSTeK Computer Inc. δηλώνει ότι αυτή η συσκευή συμμορφώνεται με τις θεμελιώδεις απαιτήσεις και άλλες σχετικές διατάξεις των Οδηγιών της ΕΕ. Το πλήρες κείμενο της δήλωσης συμμόρφωσης είναι διαθέσιμο στη διεύθυνση: www.asus.com/support

Magyar Az ASUSTeK Computer Inc. ezennel kijelenti, hogy ez az eszköz megfelel a kapcsolódó irányelvek lényeges követelményeinek és egyéb vonatkozó rendelkezéseinek. Az EU megfélelősegi nyilatkozat teljes szövege innen letölthető: www.asus.com/support

Latviski ASUSTeK Computer Inc. ar šo paziņo, ka šī ierīce atbilst saistošo Direktīvu būtiskajām prasībām un citiem citiem saistošajiem nosacījumiem. Pilns ES atbilstības paziņojuma teksts pieejams šeit: www.asus.com/support

Lietuvių „ASUSTeK Computer Inc.“ šiuo tvirtina, kad šis įrenginys atitinka pagrindinius reikalavimus ir kitas svarbias susijusių direktyvų nuostatas. Visą ES atitikties deklaracijos tekstą galima rasti: www.asus.com/support

Norsk ASUSTeK Computer Inc. erklærer herved at denne enheten er i samsvar med hovedsaklige krav og andre relevante forskrifter i relaterede direktiver. Fullstendig tekst for EU-samsvarserklæringen finnes på: www.asus.com/support

Polski Firma ASUSTeK Computer Inc. niniejszym oświadcza, że urządzenie to jest zgodne z zasadniczymi wymogami i innymi właściwymi postanowieniami powiązanych dyrektyw. Pełny tekst deklaracji zgodności UE jest dostępny pod adresem: www.asus.com/support

Português A ASUSTeK Computer Inc. declara que este dispositivo está em conformidade com os requisitos essenciais e outras disposições relevantes das Diretivas relacionadas. Texto integral da declaração da UE disponível em: www.asus.com/support

Română ASUSTeK Computer Inc. declară că acest dispozitiv se conformează cerințelor esențiale și altor prevederi relevante ale directivelor conexe. Textul complet al declarației de conformitate a Uniunii Europene se găsește la: www.asus.com/support

Srpski ASUSTeK Computer Inc. ovim izjavljuje da je ovaj uređaj u saglasnosti sa osnovnim zahtevima i drugim relevantnijim odredbama povezanih Direktiva. Pun tekst EU deklaracije o usaglasenosti je dostupan da adres: www.asus.com/support

Slovensky Spoločnosť ASUSTeK Computer Inc. týmto vyhlasuje, že toto zariadenie vyhovuje základným požiadavkám a ostatým príslušným ustanoveniam príslušných smerníc. Celý text vyhlásenia o zhode pre štáty EÚ je dostupný na adrese: www.asus.com/support

Slovenščina ASUSTeK Computer Inc. izjavlja, da je ta naprava skladna z bistvenimi zahtevami in drugimi ustreznimi določbami povezanih direktiv. Celotno besedilo EU-izjave o skladnosti je na voljo na spletnem mestu: www.asus.com/support

Español Por la presente, ASUSTeK Computer Inc. declara que este dispositivo cumple los requisitos básicos y otras disposiciones pertinentes de las directivas relacionadas. El texto completo de la declaración de la UE de conformidad está disponible en: www.asus.com/support

Svenska ASUSTeK Computer Inc. förklarar härmed att denna enhet överensstämmer med de grundläggande kraven och andra relevanta föreskrifter i relaterade direktiv. Fulltext av EU-försäkran om överensstämmelse finns på: www.asus.com/support

Українська ASUSTeK Computer Inc. заявляє, що цей пристрій відповідає основним вимогам та іншим відповідним положенням відповідних Директив. Повний текст декларації відповідності стандартам ЄС доступний на: www.asus.com/support

Türkçe ASUSTeK Computer Inc., bu aygıtın temel gereksinimlerle ve ilişkili Yönergelerin diğer ilgili kullarıyla uyumlu olduğunu beyan eder. AB uyuşluk bildirimini tam metni şu adreste bulunabilir: www.asus.com/support

Bosanski ASUSTeK Computer Inc. ovim izjavljuje da je ovaj uređaj uskladen sa bitnim zahtjevima i ostalim odgovarajućim odredbama vezanih direktiva. Cijeli tekst EU izjave o uskladenosti dostupan je na: www.asus.com/support

ASUS contact information

ASUSTeK COMPUTER INC.

Address 1F., No. 15, Lide Rd., Beitou Dist., Taipei City 112, Taiwan
Telephone +886-2-2894-3447
Fax +886-2-2890-7798
Web site <https://www.asus.com>

Technical Support

Telephone +86-21-38429911
Online support <https://qr.asus.com/techserv>

ASUS COMPUTER INTERNATIONAL (America)

Address 48720 Kato Rd., Fremont, CA 94538, USA
Telephone +1-510-739-3777
Fax +1-510-608-4555
Web site <https://www.asus.com/us/>

Technical Support

Support fax +1-812-284-0883
Telephone +1-812-282-2787
Online support <https://qr.asus.com/techserv>

ASUS COMPUTER GmbH (Germany and Austria)

Address Harkortstrasse 21-23, 40880 Ratingen, Germany
Web site <https://www.asus.com/de>
Online contact <https://www.asus.com/support/Product/ContactUs/Services/questionform/?lang=de-de>

Technical Support

Telephone (DE) +49-2102-5789557
Telephone (AT) +43-1360-2775461
Online support <https://www.asus.com/de/support>

