

E20309

First Edition / July 2022

# IN SEARCH OF INCREDIBLE



Service Manual

**ASUS**

## COPYRIGHT INFORMATION

No part of this manual, including the products and software described in it, may be reproduced, transmitted, transcribed, stored in a retrieval system, or translated into any language in any form or by any means, except documentation kept by the purchaser for backup purposes, without the express written permission of ASUSTeK COMPUTER INC. ("ASUS").

ASUS PROVIDES THIS MANUAL "AS IS" WITHOUT WARRANTY OF ANY KIND, EITHER EXPRESS OR IMPLIED, INCLUDING BUT NOT LIMITED TO THE IMPLIED WARRANTIES OR CONDITIONS OF MERCHANTABILITY OR FITNESS FOR A PARTICULAR PURPOSE. IN NO EVENT SHALL ASUS, ITS DIRECTORS, OFFICERS, EMPLOYEES OR AGENTS BE LIABLE FOR ANY INDIRECT, SPECIAL, INCIDENTAL, OR CONSEQUENTIAL DAMAGES (INCLUDING DAMAGES FOR LOSS OF PROFITS, LOSS OF BUSINESS, LOSS OF USE OR DATA, INTERRUPTION OF BUSINESS AND THE LIKE), EVEN IF ASUS HAS BEEN ADVISED OF THE POSSIBILITY OF SUCH DAMAGES ARISING FROM ANY DEFECT OR ERROR IN THIS MANUAL OR PRODUCT.

Products and corporate names appearing in this manual may or may not be registered trademarks or copyrights of their respective companies, and are used only for identification or explanation and to the owners' benefit, without intent to infringe.

SPECIFICATIONS AND INFORMATION CONTAINED IN THIS MANUAL ARE FURNISHED FOR INFORMATIONAL USE ONLY, AND ARE SUBJECT TO CHANGE AT ANY TIME WITHOUT NOTICE, AND SHOULD NOT BE CONSTRUED AS A COMMITMENT BY ASUS. ASUS ASSUMES NO RESPONSIBILITY OR LIABILITY FOR ANY ERRORS OR INACCURACIES THAT MAY APPEAR IN THIS MANUAL, INCLUDING THE PRODUCTS AND SOFTWARE DESCRIBED IN IT.

Copyright © 2022 ASUSTeK COMPUTER INC. All Rights Reserved.

## LIMITATION OF LIABILITY

Circumstances may arise where because of a default on ASUS' part or other liability, you are entitled to recover damages from ASUS. In each such instance, regardless of the basis on which you are entitled to claim damages from ASUS, ASUS is liable for no more than damages for bodily injury (including death) and damage to real property and tangible personal property; or any other actual and direct damages resulted from omission or failure of performing legal duties under this Warranty Statement, up to the listed contract price of each product.

ASUS will only be responsible for or indemnify you for loss, damages or claims based in contract, tort or infringement under this Warranty Statement.

This limit also applies to ASUS' suppliers and its reseller. It is the maximum for which ASUS, its suppliers, and your reseller are collectively responsible.

UNDER NO CIRCUMSTANCES IS ASUS LIABLE FOR ANY OF THE FOLLOWING: (1) THIRD-PARTY CLAIMS AGAINST YOU FOR DAMAGES; (2) LOSS OF, OR DAMAGE TO, YOUR RECORDS OR DATA; OR (3) SPECIAL, INCIDENTAL, OR INDIRECT DAMAGES OR FOR ANY ECONOMIC CONSEQUENTIAL DAMAGES (INCLUDING LOST PROFITS OR SAVINGS), EVEN IF ASUS, ITS SUPPLIERS OR YOUR RESELLER IS INFORMED OF THEIR POSSIBILITY.

## SERVICE AND SUPPORT

Visit our multi-language website at <https://www.asus.com/support/>

## Table of Contents

Disclaimer .....	4
Safety precautions.....	4
Major components.....	6
Installation tools.....	7
Removing the bottom cover .....	8
Disconnecting the battery .....	13
Replacing the battery.....	15
Replacing the M.2 SSD module .....	22
Replacing the RAM module .....	25
Replacing the LCD module .....	29
Replacing the motherboard .....	38
Screw map.....	57
Wiring and connection diagrams .....	63

## Disclaimer

ASUS is not responsible for direct, indirect, intentional or unintentional damages resulting from improper installation and operation.

## Safety precautions

- Keep liquids or moisture away from your Notebook PC before installing or removing any components.
- Ensure to place your Notebook PC on a stable surface before installing or removing any components.
- Detach the clip or flap before removing the signal cables to prevent damage.
- Disconnect the power plug by pulling the plug evenly to avoid damage. Ensure to connect the signal cables in the correct orientation.
- Disconnect all power cables and remove the battery pack (if applicable) before cleaning your Notebook PC with liquid detergent to avoid risk of electric shock.
- Disconnect all power cables and remove the battery pack (if applicable) before installing or removing any components. Ensure to read and follow the instructions in the manual.

- Before handling components, use a grounded wrist strap or touch a safely grounded object to avoid damaging them due to static electricity.
- Keep liquids or moisture away from your Notebook PC to avoid short circuits.
- Hold components by the edges to avoid touching the ICs.
- Ensure to properly install all the components before connecting the AC power.
- Do not use power adapters or batteries from other devices to reduce the risk of injury to persons due to fire or explosion. Use only certified power adapters or batteries supplied by the manufacturer or authorized retailers.
- Ensure to install the correct screw models on your Notebook PC to prevent damage.

# Major components

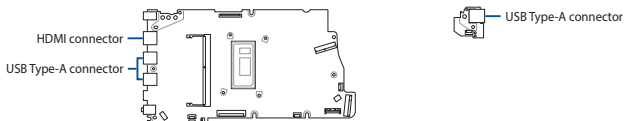

## Motherboard with ports and connectors



**M.2 SSD module**

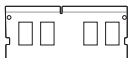

**RAM module**

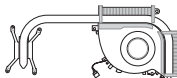

**Thermal module**

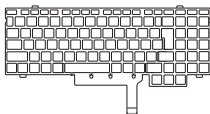

**Keyboard**

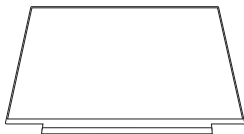

**LCD panel module**

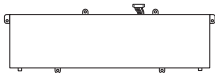

**Battery and power connector**



**Power adapter**

---

**NOTE:**

- The illustrations are for reference only.
  - The maintenance procedures described in this manual depend on the model configuration and may not reflect the entire servicing process. For servicing those components that are not covered in this manual, please visit an authorized service center for further assistance.
- 

## Installation tools



**Screwdriver**



**Plastic blade**



**Tweezers**

# Removing the bottom cover

---

**NOTE:** The appearance of your Notebook PC's bottom view may vary per model.

---

- A. Remove the screw(s) from the Notebook PC's bottom cover.

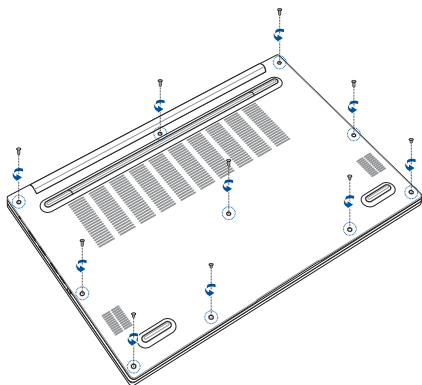



- B. Place your Notebook PC in the orientation as shown in the illustration below.
- C. Starting from the bottom edge, pry loose the bottom cover.

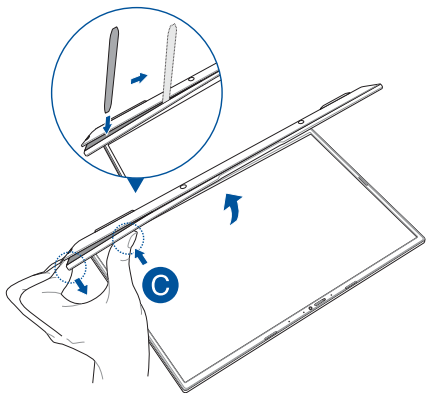

- D. In the orientation shown, use the plastic blade to pry open the indicated area of the bottom cover.

---

**IMPORTANT!** Avoid sliding the plastic blade along the side of your Notebook PC to prevent damage.

---

- E. Remove the bottom cover.

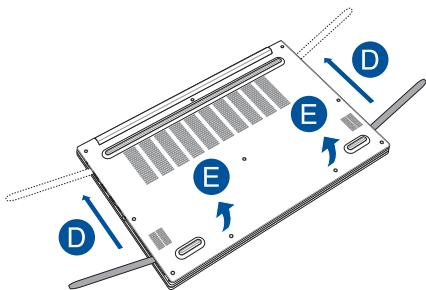

To reattach the bottom cover:

- A. Align and reattach the bottom cover.

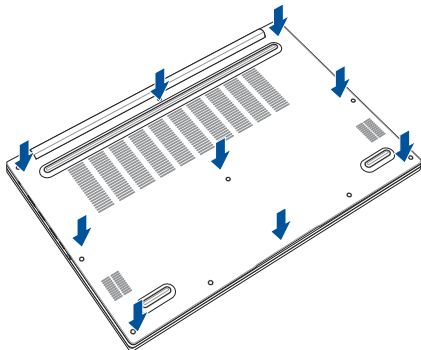

- B. Secure the bottom cover using the screw(s) you removed earlier.

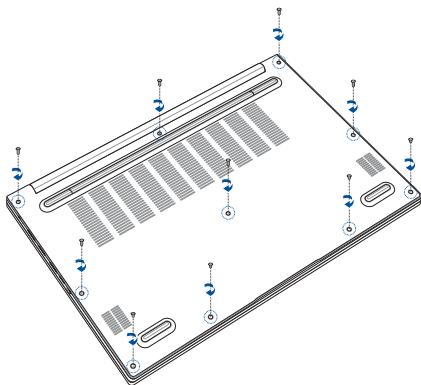

# Disconnecting the battery

- A. Remove the bottom cover.
- 

**NOTE:** For more details, refer to the *Removing the bottom cover* section in this manual.

---

- B. Locate and disconnect the battery power cable as shown in the illustration below.

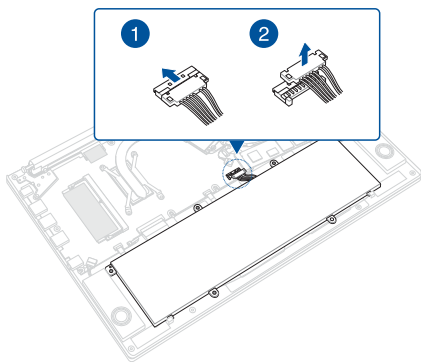

To connect the battery, align and connect the cable to the battery connector before you reattach the bottom cover.

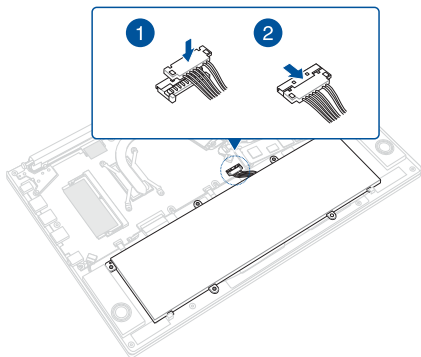

# Replacing the battery

Refer to the following steps when installing a compatible battery in your Notebook PC:

---

**IMPORTANT!** Purchase your battery from authorized retailers of this Notebook PC to ensure maximum compatibility and reliability.

---

---

**WARNING!** Disconnect all the connected peripherals, any telephone or telecommunication lines and power connector (such as external power supply, battery pack, etc.) before removing the bottom cover.

---

**NOTE:**

- The appearance of your Notebook PC's bottom view and battery may vary per model but the module installation remains the same.
  - It is recommended that you install the battery under professional supervision. You may also visit an authorized service center for further assistance.
-

- A. Remove the bottom cover and disconnect the battery.

---

**NOTE:** For more details, refer to the *Removing the bottom cover* and *Disconnecting the battery* sections in this manual.

---

- B. Remove the screw(s) from the battery.
- C. Remove the battery.

X1405

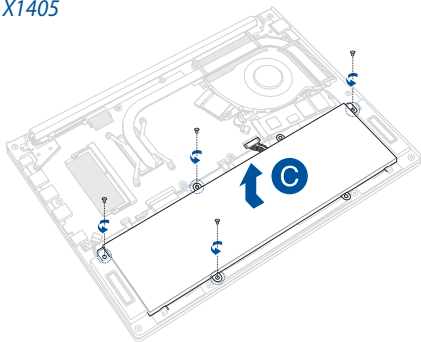



X1505/X1605

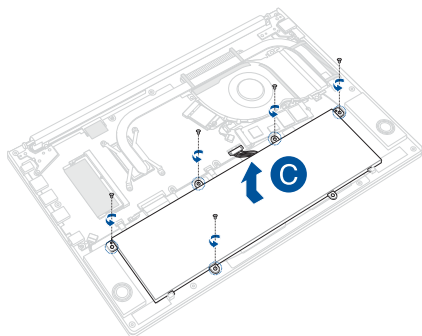

- D. (Optional) Remove the battery power cable.

*X1605*

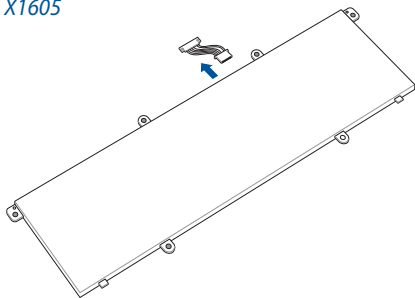

To install the new battery:

- A. Prepare the new battery.
- B. (Optional) Connect the battery power cable to the battery.

*X1605*

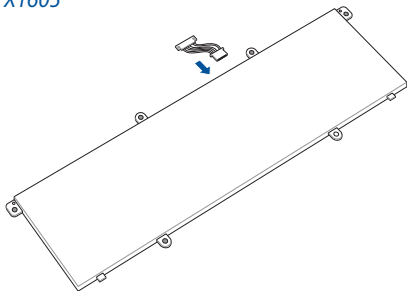

- C. Reinstall the battery.
- D. Secure the battery using the screw(s) you removed earlier.

*X1405*

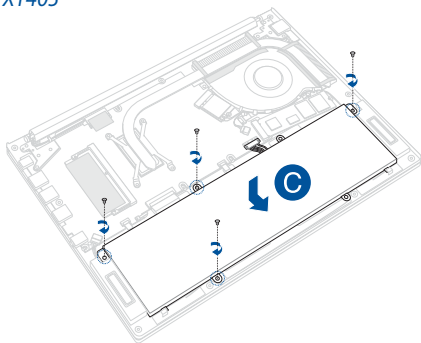

X1505/X1605

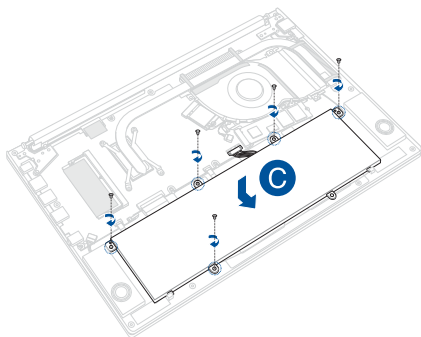

## Replacing the M.2 SSD module

Refer to the following steps when installing a compatible M.2 SSD module in your Notebook PC:

---

**IMPORTANT!** Purchase your M.2 SSD module from authorized retailers of this Notebook PC to ensure maximum compatibility and reliability.

---

---

**WARNING!** Disconnect all the connected peripherals, any telephone or telecommunication lines and power connector (such as external power supply, battery pack, etc.) before removing the bottom cover.

---

---

**NOTE:**

- The appearance of your Notebook PC's bottom view and M.2 SSD module may vary per model but the module installation remains the same.
  - It is recommended that you install the M.2 SSD module under professional supervision. You may also visit an authorized service center for further assistance.
-

- A. Remove the bottom cover and disconnect the battery.

---

**NOTE:** For more details, refer to the *Removing the bottom cover* and *Disconnecting the battery* sections in this manual.

---

- B. Remove the screw from the M.2 SSD module.
- C. Remove the M.2 SSD module from the motherboard.

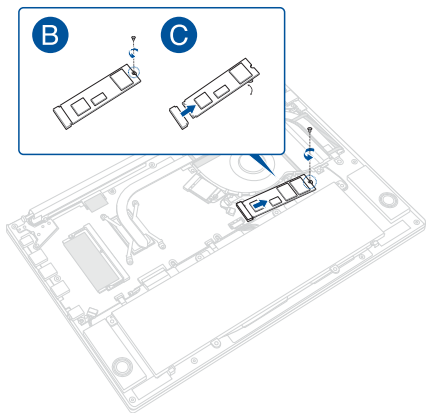

To install the new M.2 SSD module:

- A. Prepare the new M.2 SSD module.
- B. Align and insert the M.2 SSD module into the M.2 connector on the motherboard.
- C. Secure the M.2 SSD module in place using the screw you removed earlier.

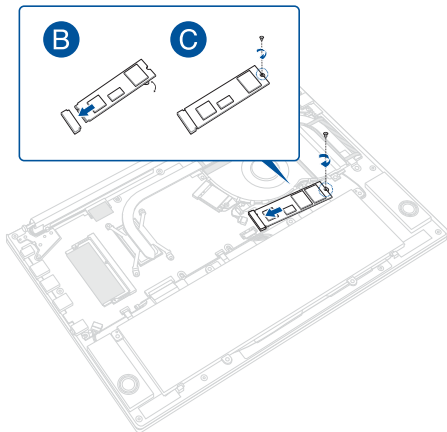



## Replacing the RAM module

Upgrade the memory capacity of your Notebook PC by installing a RAM (Random Access Memory) module in the memory module compartment. Refer to the following steps when installing a RAM module in your Notebook PC:

---

**IMPORTANT!** Visit an authorized service center or retailer for information on RAM module upgrades for your Notebook PC. Purchase your RAM modules from authorized retailers of this Notebook PC to ensure maximum compatibility and reliability.

---

---

**WARNING!** Disconnect all the connected peripherals, any telephone or telecommunication lines and power connector (such as external power supply, battery pack, etc.) before removing the bottom cover.

---

**NOTE:**

- The appearance of your Notebook PC's bottom view and RAM module may vary per model but the RAM module installation remains the same.
  - It is recommended that you install the RAM module under professional supervision. You may also visit an authorized service center for further assistance.
-

- A. Remove the bottom cover and disconnect the battery.

---

**NOTE:** For more details, refer to the *Removing the bottom cover* and *Disconnecting the battery* sections in this manual.

---

- B. Push the clips outwards to remove the RAM module.

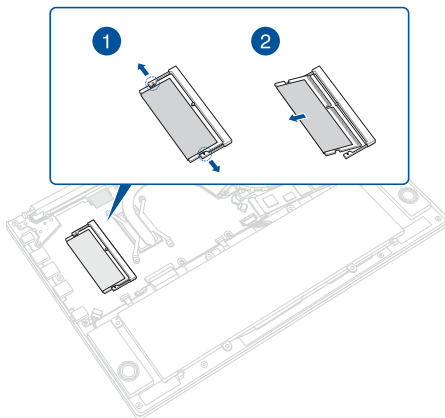

C. Remove the mylar from the RAM module.

1

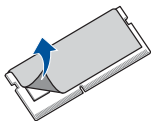

2

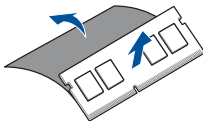

To install the new RAM module:

A. Prepare the new RAM module.

B. Reattach the mylar to the RAM module.

1

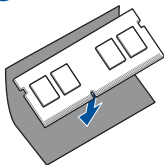

2

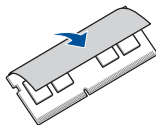

- C. Align and insert the RAM module into the RAM module slot.
- D. Push down the RAM module until it clicks in place.

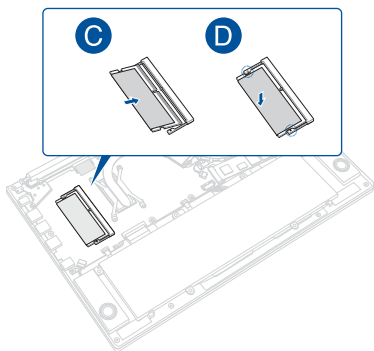

## Replacing the LCD module

---

**IMPORTANT!** Do not bend the LCD panel in any ways to avoid risk of LCD panel leakage.

---

**NOTE:** The illustrations are for reference only.

---

- A. Remove the bottom cover and disconnect the battery.
- 

**NOTE:** For more details, refer to the *Removing the bottom cover* and *Disconnecting the battery* sections in this manual.

---

- B. Locate and remove the connector as shown in the illustration below.

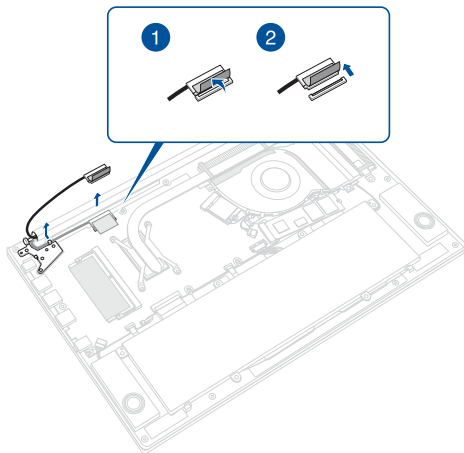

- C. Remove the screw(s) from the hinge(s).

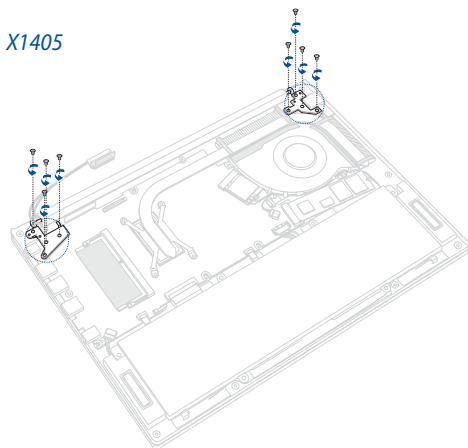

X1505

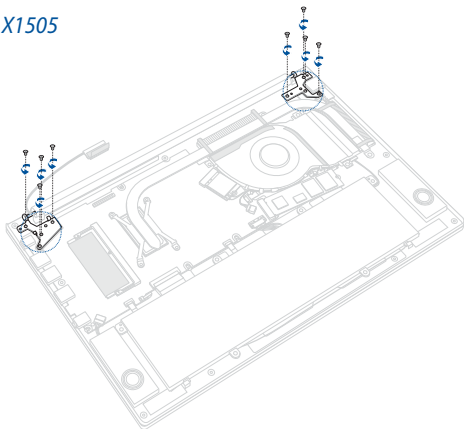

X1605

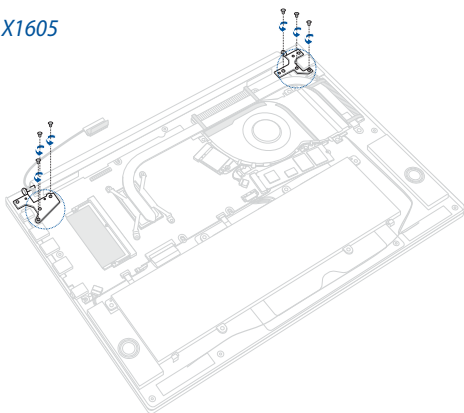



- D. Release the LCD panel module as shown in the illustration below.

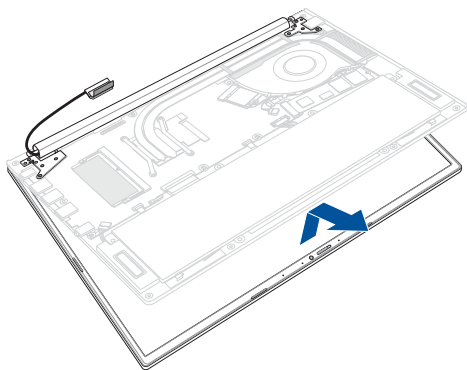

To install the new LCD panel module:

- A. Prepare the new LCD panel module.
- B. In the orientation shown, align and place the hinge(s) of the display panel on the screw holes of the motherboard.

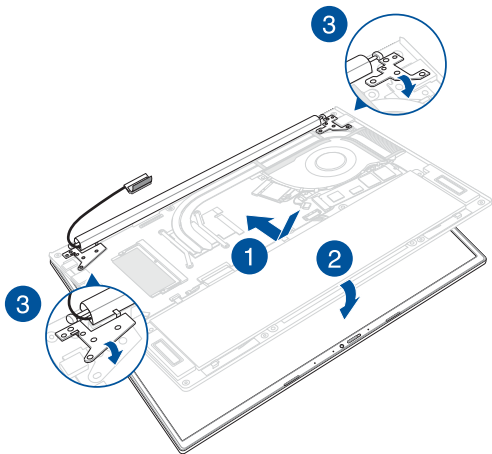

- C. Secure the hinge(s) using the screw(s) you removed earlier.

*X1405*

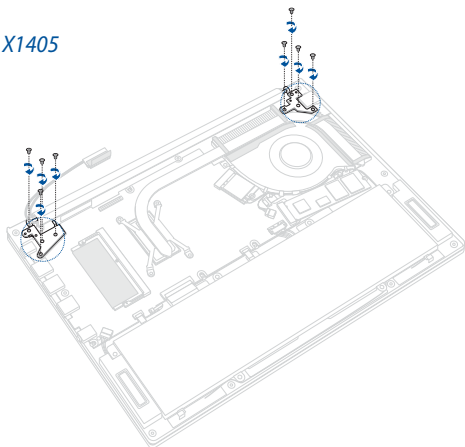

X1505

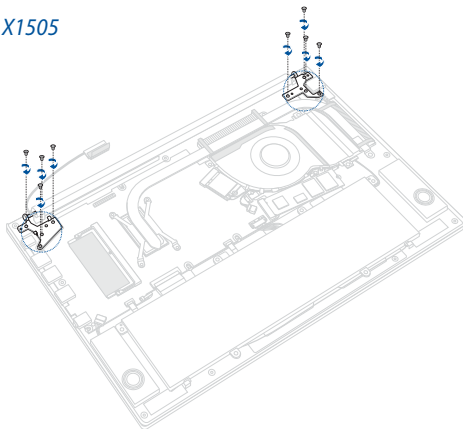

X1605

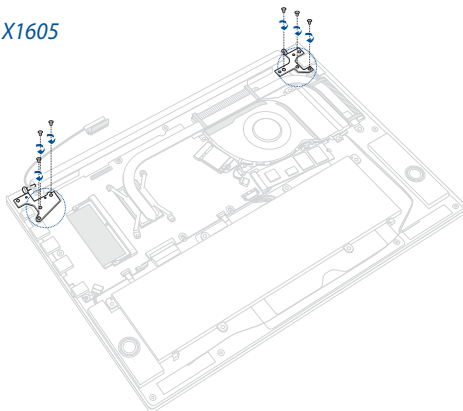

D. Reconnect the connector as shown in the illustration below.

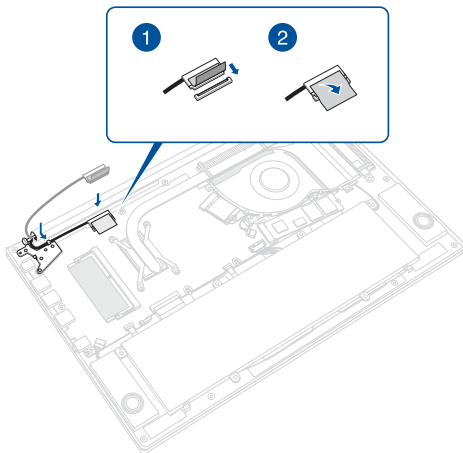

# Replacing the motherboard

Refer to the following steps when installing the motherboard to your Notebook PC:

---

**IMPORTANT!** Purchase your motherboard from authorized retailers of this Notebook PC to ensure maximum compatibility and reliability.

---

**WARNING!** Disconnect all the connected peripherals, any telephone or telecommunication lines and power connector (such as external power supply, battery pack, etc.) before removing the bottom cover.

---

**NOTE:**

- The appearance of your Notebook PC's bottom view and motherboard may vary per model but the module installation remains the same.
  - It is recommended that you install the motherboard under professional supervision. You may also visit an authorized service center for further assistance.
-

- A. Remove the bottom cover and disconnect the battery.

---

**NOTE:** For more details, refer to the *Removing the bottom cover and Disconnecting the battery* sections in this manual.

---

- B. Remove the battery.

---

**NOTE:** For more details, refer to the *Replacing the battery* section in this manual.

---

- C. Remove the M.2 SSD module and the RAM module.

---

**NOTE:** For more details, refer to the *Replacing the M.2 SSD module and Replacing the RAM module* sections in this manual.

---

- D. Remove the LCD module.

---

**NOTE:** For more details, refer to the *Replacing the LCD module* section in this manual.

---

- E. Remove the screw(s) one by one in the sequence shown in the illustrations below.
- F. Remove the cooling radiator.

X1405

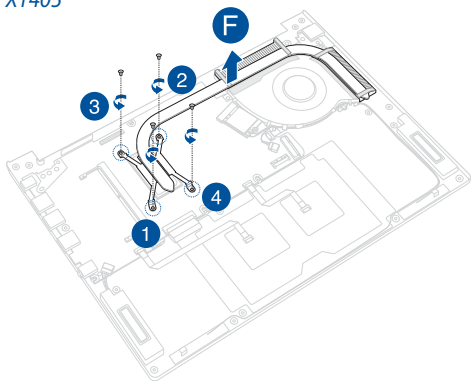



## X1505

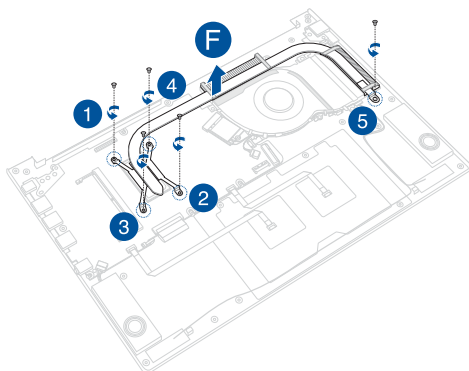

## X1605

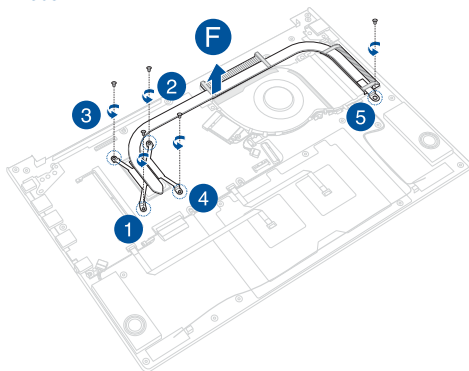

- G. Remove the WLAN module.
- H. Unroute the antenna(s) from the cable guide(s) as shown in the illustration below.

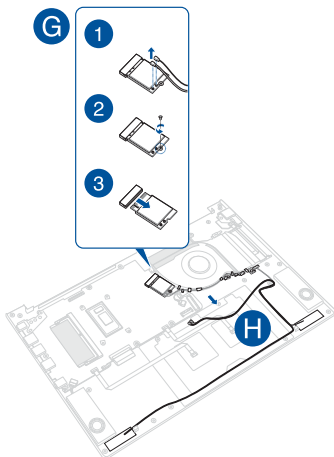

- I. Locate and remove the fan connector.
- J. Remove the screw(s) from the fan module then remove the fan module.

*X1405*

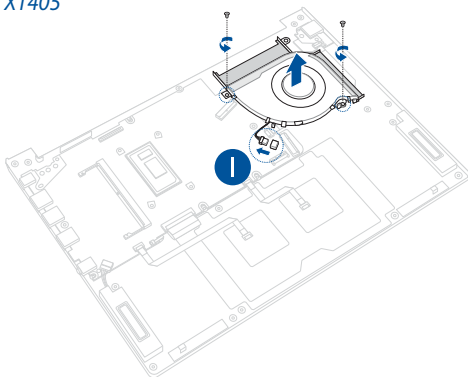

X1505/X1605

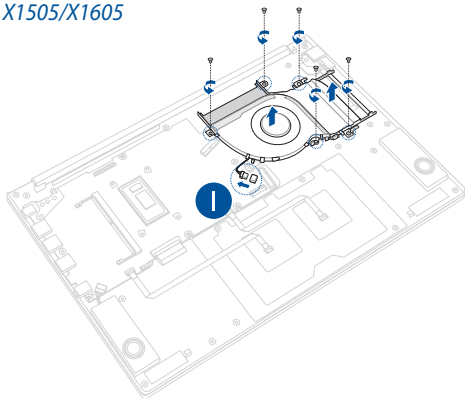

- K. Remove all the cable(s) and connector(s) as shown in the illustration below.

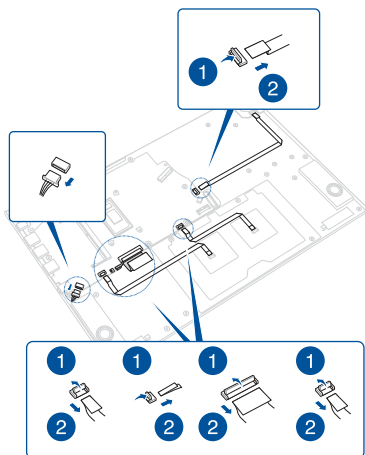

- L. Remove the screw(s) from the motherboard.

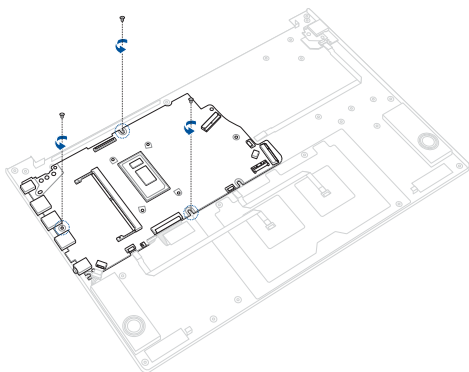

M. Remove the motherboard.

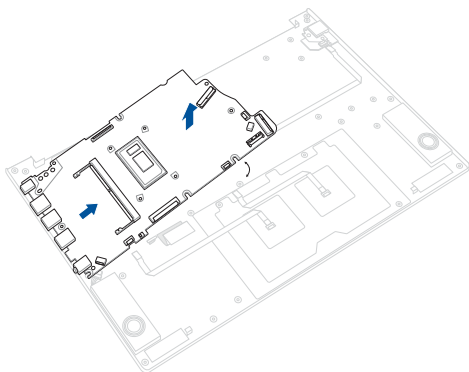

To install the new motherboard:

- A. Prepare the new motherboard.
- B. Align and place the motherboard in the chassis as shown in the illustration below.

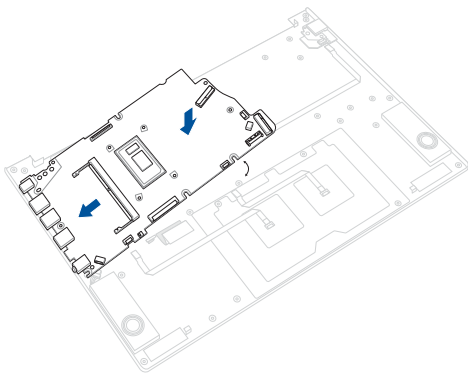



- C. Secure the motherboard using the screw(s) you removed earlier.

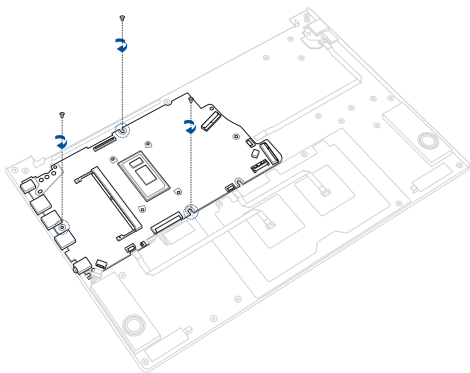

- D. Reconnect all the cable(s) and connector(s) as shown in the illustration below.

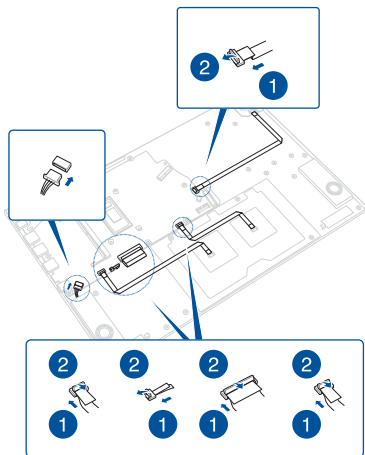

- E. Reinstall the fan module then secure the fan module using the screw(s) you removed earlier.
- F. Reconnect the fan connector.

X1405

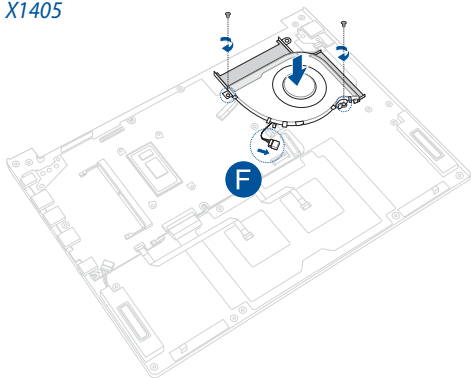

X1505/X1605

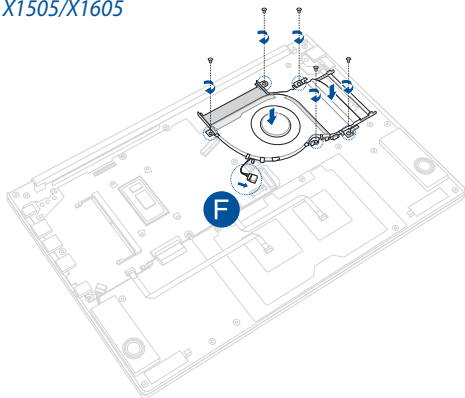

- G. Route the antenna(s) through the cable guide(s) as shown in the illustration below.
- H. Reinstall the WLAN module.

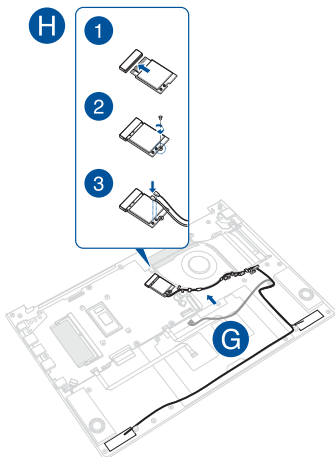

- I. Reinstall the cooling radiator.
- J. Secure the screw(s) one by one in the sequence shown in the illustrations below.

X1405

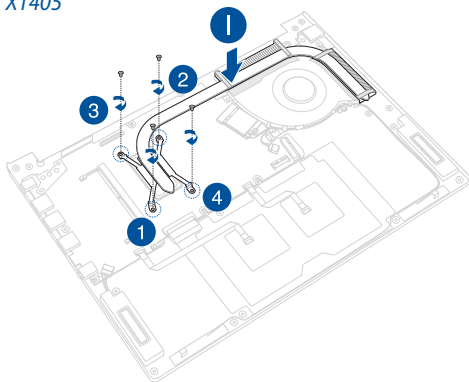

X1505

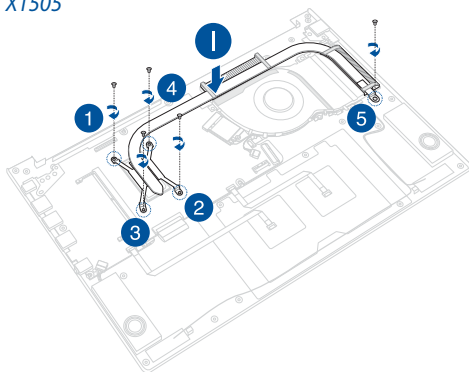

X1605

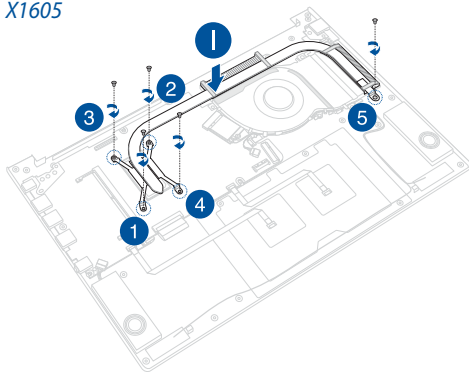

- K. Reinstall the LCD module.

---

**NOTE:** For more details, refer to the *Replacing the LCD module* section in this manual.

---

- L. Reinstall the M.2 SSD module and the RAM module.

---

**NOTE:** For more details, refer to the *Replacing the M.2 SSD module* and *Replacing the RAM module* sections in this manual.

---

- M. Reinstall the battery.

---

**NOTE:** For more details, refer to the *Replacing the battery* section in this manual.

---



# Screw map

## Cover screw map

X1405

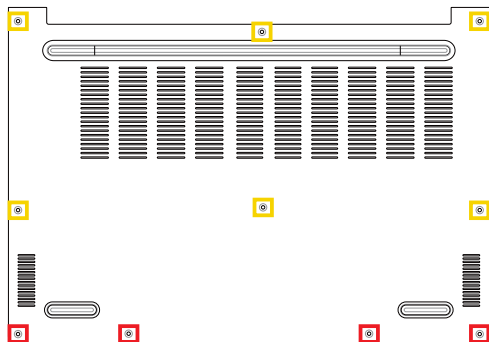

■ M2.0 X 7.0L (6PCS)

■ M2.0 X 4.0L (4PCS)

## X1505

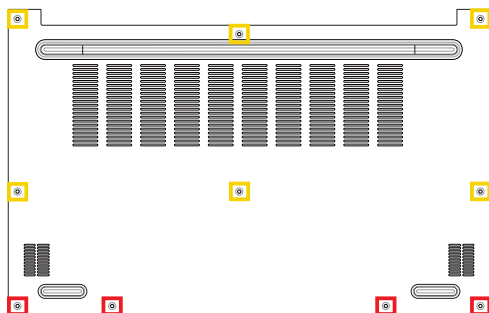

■ M2.0 X 6.5L (6PCS)

■ M2.0 X 4.0L (4PCS)

## X1605

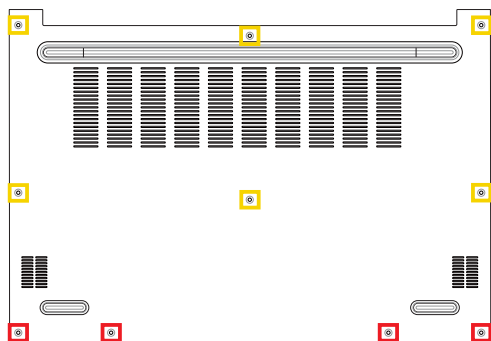

■ M2.0 X 7.0L (6PCS)

■ M2.0 X 3.5L (4PCS)

## Hinge screw map

X1405

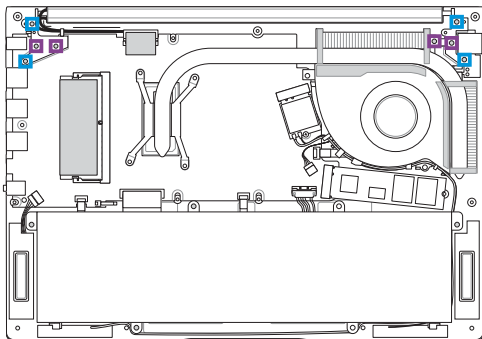

■ M2.5 X 5.0L (4PCS)

■ M2.5 X 3.5L (4PCS)

## X1505

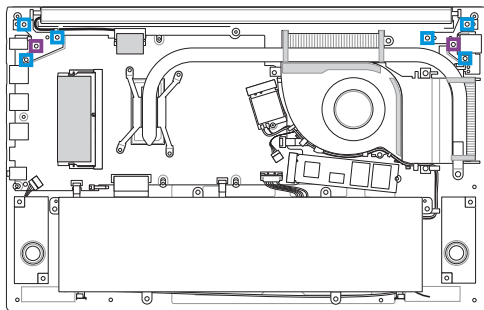

■ M2.5 X 4.5L (6PCS)

■ M2.5 X 3.5L (2PCS)

## X1605

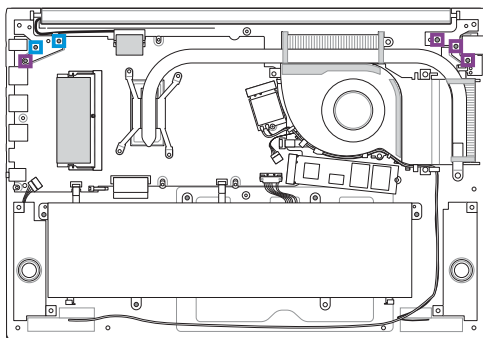

■ M2.5 X 4.0L (2PCS)

■ M2.5 X 5.0L (4PCS)

# Wiring and connection diagrams

**NOTE:** The illustrations are for reference only.

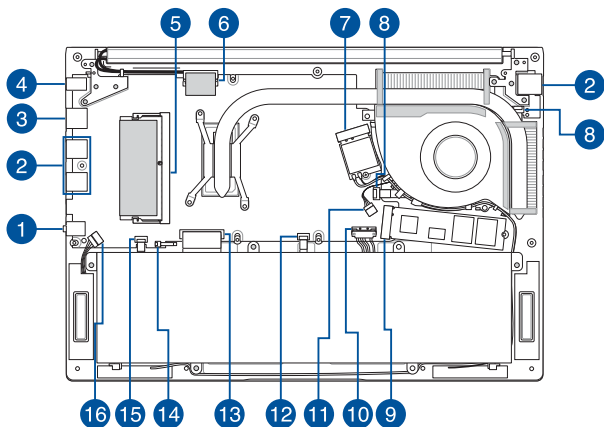

## Top View

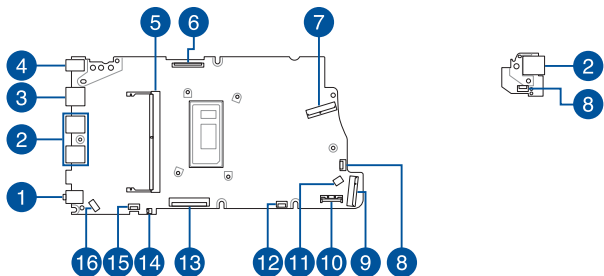

## Bottom View

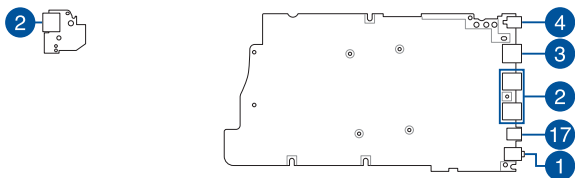

1. Headphone/Headset/  
Microphone jack
2. USB Type-A connector
3. HDMI connector
4. Power supply connector
5. DDR connector
6. eDP/Camera connector
7. WLAN connector
8. I/O FFC connector
9. SSD connector
10. Battery connector
11. Fan connector
12. Touchpad connector
13. Keyboard connector
14. Keyboard backlight connector
15. Fingerprint sensor connector
16. Speaker connector
17. USB Type-C® connector