

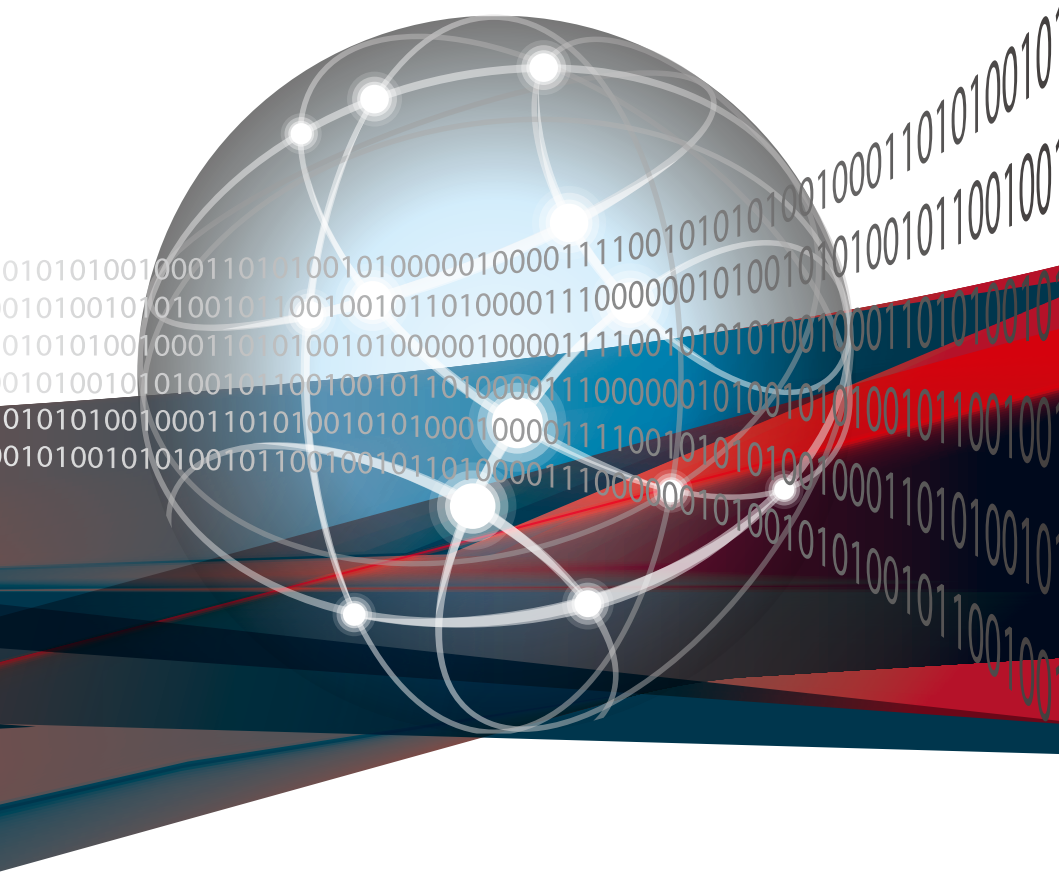

# ESC4000-E11

## 2U Rackmount Server User Guide



E22374  
Revised Edition V3  
August 2023

**Copyright © 2023 ASUSTeK COMPUTER INC. All Rights Reserved.**

No part of this manual, including the products and software described in it, may be reproduced, transmitted, transcribed, stored in a retrieval system, or translated into any language in any form or by any means, except documentation kept by the purchaser for backup purposes, without the express written permission of ASUSTeK COMPUTER INC. ("ASUS").

ASUS provides this manual "as is" without warranty of any kind, either express or implied, including but not limited to the implied warranties or conditions of merchantability or fitness for a particular purpose. In no event shall ASUS, its directors, officers, employees, or agents be liable for any indirect, special, incidental, or consequential damages (including damages for loss of profits, loss of business, loss of use or data, interruption of business and the like), even if ASUS has been advised of the possibility of such damages arising from any defect or error in this manual or product.

Specifications and information contained in this manual are furnished for informational use only, and are subject to change at any time without notice, and should not be construed as a commitment by ASUS. ASUS assumes no responsibility or liability for any errors or inaccuracies that may appear in this manual, including the products and software described in it.

Product warranty or service will not be extended if: (1) the product is repaired, modified or altered, unless such repair, modification or alteration is authorized in writing by ASUS; or (2) the serial number of the product is defaced or missing.

Products and corporate names appearing in this manual may or may not be registered trademarks or copyrights of their respective companies, and are used only for identification or explanation and to the owners' benefit, without intent to infringe.

# Contents

Safety information.....	vii
About this guide.....	ix

## Chapter 1: Product Introduction

1.1	System package contents.....	1-2
1.2	Serial number label.....	1-2
1.3	System specifications .....	1-3
1.4	Front panel features.....	1-5
1.5	Rear panel features.....	1-6
1.6	Internal features .....	1-7
1.7	LED information .....	1-8
1.7.1	Front panel LEDs .....	1-8
1.7.2	Rear panel LEDs.....	1-9
1.7.3	LAN (RJ-45) LEDs .....	1-10
1.7.4	HDD status LEDs.....	1-11

## Chapter 2: Hardware Setup

2.1	Chassis cover.....	2-2
2.1.1	Air duct.....	2-4
2.2	Central Processing Unit (CPU) .....	2-5
2.2.1	Installing the CPU and heatsink.....	2-5
2.2.2	Installing the CPU and liquid cooling module.....	2-8
2.3	System memory .....	2-9
2.3.1	Overview .....	2-9
2.3.2	Memory configurations.....	2-10
2.3.3	Installing a DIMM .....	2-10
2.3.4	Removing a DIMM .....	2-11
2.4	Storage devices.....	2-12
2.4.1	Installing a 3.5-inch storage device.....	2-12
2.4.2	Installing a 2.5-inch storage device.....	2-14

# Contents

<b>2.5</b>	<b>Expansion slots</b> .....	<b>2-16</b>
2.5.1	Installing a PCIe expansion card.....	2-16
2.5.2	Installing a PIKE II or RAID card.....	2-19
2.5.3	Installing the Cache Vault Power Module .....	2-30
2.5.4	Installing an M.2 (NGFF) card.....	2-33
2.5.5	Configuring an expansion card .....	2-35
<b>2.6</b>	<b>Cable connections</b> .....	<b>2-36</b>
<b>2.7</b>	<b>SATA/SAS/NVMe backplane cabling</b> .....	<b>2-37</b>
<b>2.8</b>	<b>Removable/optional components</b> .....	<b>2-38</b>
2.8.1	System fans .....	2-38
2.8.2	Redundant power supply units.....	2-39
2.8.3	Installing a GPU .....	2-41
2.8.4	Installing a GPU liquid cooling module.....	2-45
2.8.5	Installing a GPU bridge .....	2-49
2.8.6	PFR module .....	2-50
<b>2.9</b>	<b>Rail kit options</b> .....	<b>2-51</b>

## Chapter 3: Motherboard Information

<b>3.1</b>	<b>Motherboard layout</b> .....	<b>3-2</b>
<b>3.2</b>	<b>Central Processing Unit (CPU)</b> .....	<b>3-4</b>
<b>3.3</b>	<b>Dual Inline Memory Module (DIMM)</b> .....	<b>3-5</b>
<b>3.4</b>	<b>Jumpers</b> .....	<b>3-6</b>
<b>3.5</b>	<b>Internal connectors</b> .....	<b>3-11</b>
<b>3.6</b>	<b>Onboard LEDs</b> .....	<b>3-21</b>

# Contents

## Chapter 4: BIOS Setup

<b>4.1</b>	<b>Managing and updating your BIOS .....</b>	<b>4-2</b>
4.1.1	ASUS CrashFree BIOS 3 utility.....	4-2
4.1.2	ASUS EZ Flash Utility .....	4-3
<b>4.2</b>	<b>BIOS setup program .....</b>	<b>4-4</b>
4.2.1	BIOS menu screen.....	4-5
4.2.2	Menu bar .....	4-5
<b>4.3</b>	<b>Main menu .....</b>	<b>4-7</b>
<b>4.4</b>	<b>Performance Tuning menu.....</b>	<b>4-8</b>
<b>4.5</b>	<b>Advanced menu .....</b>	<b>4-10</b>
4.5.1	Trusted Computing.....	4-10
4.5.2	ACPI Settings.....	4-11
4.5.3	Redfish Host Interface Settings.....	4-11
4.5.4	Onboard LAN Configuration.....	4-12
4.5.5	UEFI Variables Protection.....	4-12
4.5.6	Serial Port Console Redirection.....	4-13
4.5.7	SIO Configuration.....	4-16
4.5.8	PCI Subsystem Settings .....	4-17
4.5.9	USB Configuration .....	4-18
4.5.10	Network Stack Configuration.....	4-19
4.5.11	NVMe Configuration.....	4-20
4.5.12	APM Configuration .....	4-21
4.5.13	T1s Auth Configuration .....	4-22
4.5.14	Third-party UEFI driver configurations .....	4-23

<b>4.6</b>	<b>Platform Configuration menu .....</b>	<b>4-24</b>
4.6.1	PCH-IO Configuration .....	4-25
4.6.2	Miscellaneous Configuration .....	4-25
4.6.3	Server ME Configuration .....	4-26
4.6.4	Runtime Error Logging Support .....	4-27
<b>4.7</b>	<b>Socket Configuration menu .....</b>	<b>4-28</b>
4.7.1	Processor Configuration .....	4-29
4.7.2	Common RefCode Configuration .....	4-36
4.7.3	Uncore Configuration .....	4-36
4.7.4	Memory Configuration .....	4-37
4.7.5	IIO Configuration .....	4-39
4.7.6	Advanced Power Management Configuration .....	4-39
<b>4.8</b>	<b>Security menu .....</b>	<b>4-40</b>
<b>4.9</b>	<b>Boot menu .....</b>	<b>4-42</b>
<b>4.10</b>	<b>Tool menu .....</b>	<b>4-43</b>
<b>4.11</b>	<b>Event Logs menu .....</b>	<b>4-44</b>
4.11.1	Change Smbios Event Log Settings .....	4-44
4.11.2	View Smbios Event Log .....	4-44
<b>4.12</b>	<b>Server Mgmt menu .....</b>	<b>4-45</b>
4.12.1	System Event Log .....	4-46
4.12.2	View FRU Information .....	4-46
4.12.3	BMC network configuration .....	4-46
4.12.4	View System Event Log .....	4-46
<b>4.13</b>	<b>Save &amp; Exit menu .....</b>	<b>4-47</b>

## **Chapter 5: Driver Installation**

<b>5.1</b>	<b>Running the Support DVD .....</b>	<b>5-2</b>
------------	--------------------------------------	------------

## **Appendix**

<b>Block diagram .....</b>	<b>A-2</b>
<b>Q-Code table .....</b>	<b>A-3</b>
<b>Notices .....</b>	<b>A-5</b>
<b>Service and Support .....</b>	<b>A-8</b>

# Safety information

## Electrical Safety

- Before installing or removing signal cables, ensure that the power cables for the system unit and all attached devices are unplugged.
- To prevent electrical shock hazard, disconnect the power cable from the electrical outlet before relocating the system.
- When adding or removing any additional devices to or from the system, ensure that the power cables for the devices are unplugged before the signal cables are connected. If possible, disconnect all power cables from the existing system before you add a device.
- If the power supply is broken, do not try to fix it by yourself. Contact a qualified service technician or your dealer.

## Operation Safety

- Any mechanical operation on this server must be conducted by certified or experienced engineers.
- Before operating the server, carefully read all the manuals included with the server package.
- Before using the server, ensure all cables are correctly connected and the power cables are not damaged. If any damage is detected, contact your dealer as soon as possible.
- To avoid short circuits, keep paper clips, screws, and staples away from connectors, slots, sockets and circuitry.
- Avoid dust, humidity, and temperature extremes. Place the server on a stable surface.



This product is equipped with a three-wire power cable and plug for the user's safety. Use the power cable with a properly grounded electrical outlet to avoid electrical shock.

## Restricted Access Location

This product is intended for installation only in a Computer Room where:

- Access can only be gained by SERVICE PERSONS or by USERS who have been instructed about the reasons for the restrictions applied to the location and about any precautions that shall be taken.
- Access is through the use of a TOOL, or other means of security, and is controlled by the authority responsible for the location.

### Heavy System

**CAUTION!** This server system is heavy. Ask for assistance when moving or carrying the system.

### **Lithium-Ion Battery Warning**

**CAUTION:** Danger of explosion if battery is incorrectly replaced. Replace only with the same or equivalent type recommended by the manufacturer. Dispose of used batteries according to the manufacturer's instructions.

### **Avertissement sur les batteries Lithium-Ion**

**ATTENTION :** Danger d'explosion si la batterie n'est pas correctement remplacée. Remplacer uniquement avec une batterie de type semblable ou équivalent, recommandée par le fabricant. Jeter les batteries usagées conformément aux instructions du fabricant.



# About this guide

## Audience

This user guide is intended for system integrators, and experienced users with at least basic knowledge of configuring a server.

## Contents

This guide contains the following parts:

**1. Chapter 1: Product Introduction**

This chapter describes the general features of the server, including sections on front panel and rear panel specifications.

**2. Chapter 2: Hardware Setup**

This chapter lists the hardware setup procedures that you have to perform when installing or removing system components.

**3. Chapter 3: Motherboard Information**

This chapter gives information about the motherboard that comes with the server. This chapter includes the motherboard layout, jumper settings, and connector locations.

**4. Chapter 4: BIOS Setup**

This chapter tells how to change system settings through the BIOS Setup menus and describes the BIOS parameters.

**5. Chapter 5: Driver Installation**

This chapter provides instructions for installing the necessary drivers for different system components.

## Conventions

To ensure that you perform certain tasks properly, take note of the following symbols used throughout this manual.



**DANGER/WARNING:** Information to prevent injury to yourself when trying to complete a task.



**CAUTION:** Information to prevent damage to the components when trying to complete a task.



**IMPORTANT:** Instructions that you **MUST** follow to complete a task.



**NOTE:** Tips and additional information to help you complete a task.

## Typography

### **Bold text**

Indicates a menu or an item to select.

### *Italics*

Used to emphasize a word or a phrase.

### <Key>

Keys enclosed in the less-than and greater-than sign means that you must press the enclosed key.

Example: <Enter> means that you must press the Enter or Return key.

### <Key1>+<Key2>+<Key3>

If you must press two or more keys simultaneously, the key names are linked with a plus sign (+).

Example: <Ctrl>+<Alt>+<Del>

### Command

Means that you must type the command exactly as shown, then supply the required item or value enclosed in brackets.

Example: At the command prompt, type the command line: **format A: /S**

## References

Refer to the following sources for additional information, and for product and software updates.

### 1. **ASUS Control Center (ACC) user guide**

This manual tells how to set up and use the proprietary ASUS server management utility.

### 2. **ASUS websites**

The ASUS websites provide updated information for all ASUS hardware and software products. Visit <https://www.asus.com> for more information.

# Product Introduction

# 1

This chapter describes the general features of the server. It includes sections on front panel and rear panel specifications.

# 1.1 System package contents

Check your system package for the following items.

ESC4000-E11	
Chassis	ASUS 2U Rackmount Chassis
Motherboard	ASUS Z13PG-D16-V2 Server Board
Accessory box	1 x ACC Instruction Card 1 x Bag of Screws 2 x AC Power Cables 8 x GPU Power Cables (Single-slot GPU Cards) 4 x GPU Power Cables (Dual-slot GPU Cards) 4 x Passive GPU Air Ducts 4 x Active GPU Air Ducts 1 x CPU Heatsink
Optional items	1 x Rail Kit 1 x Broadcom 9560 Cable Kit 1 x Broadcom 9540 Cable Kit 1 x ASUS PIKE Cable Kit 4 x GPU-specific Power Cables



- If any of the above items is damaged or missing, contact your retailer.
- Optional items come bundled if you selected them when purchasing the system and cannot be bought separately.

# 1.2 Serial number label

Before requesting support from the ASUS Technical Support team, you must take note of the product's serial number containing 12 characters such as xxS0xxxxxxx. See the figure below.

With the correct serial number of the product, ASUS Technical Support team members can then offer a quicker and satisfying solution to your problems.



The serial number is printed on the Asset tag.

## 1.3 System specifications

The ASUS ESC4000-E11 Series server features the ASUS Z13PG-D16-V2 server board. The server supports 4<sup>th</sup> Gen Intel® Xeon® Scalable Processors Family Series plus other latest technologies through the chipsets onboard.

Model Name		ESC4000-E11
Processor		2 x Socket (LGA 4677)
		4 <sup>th</sup> Gen Intel® Xeon® Scalable Processors Family (Up to 350W) UPI 16 GT/s
Core Logic		Intel® C741
Memory	Total Slots	16 (8 channels per CPU, 8 DIMM per CPU)
	Capacity	Up to 4TB per CPU socket
	Memory Type	DDR5 4800/4400 RDIMM / 3DS RDIMM * Refer to ASUS server AVL for the latest update
	Memory Size	64GB, 32GB, 16GB RDIMM 256GB, 128GB 3DS RDIMM * Refer to ASUS server AVL for the latest update
Expansion Slots	Total PCI/PCI-X/PCIe Slots	11
	Slot Type	<b>Rear:</b> - 4 x PCIe x16 slots (Gen5 x16 link, FH, FL) for dual-slot GPU cards, or - 8 x PCIe x16 slots (Gen5 x8 link, FH, FL) for single-slot GPU cards - 2 x PCIe x16 slot (Gen5 x16 link, FH, HL) <b>Front:</b> - 1 x PCIe x8 slot (Gen4 x8 link, LP, HL)
	M.2	1 x M.2 socket (Gen3 x4 link, PCIe mode, up to 2280)
Storage	SATA Controller	6 x SATA 6Gb/s ports
	SAS Controller	<b>Optional Kits:</b> ASUS PIKE II 3008 8-port SAS 12Gb/s HBA card ASUS PIKE II 3108 8-port SAS HW 12GB/s RAID card Broadcom MegaRAID 9540-8i Broadcom MegaRAID 9560-16i * RAID card requires additional cables
Storage Bays	Storage Bay	SKU-1** 2 x 2.5" SATA/SAS*/NVMe 2 x 3.5" SATA/SAS*/NVMe 2 x 3.5" SATA/SAS* SKU-2 (by request, one PCIe x8 link will be occupied) 2 x 2.5" SATA/SAS*/NVMe 4 x 3.5" SATA/SAS*/NVMe * SAS support requires an optional RAID card ** Additional 2 x NVMe support for SKU-1 requires an optional RAID card

(continued on the next page)

Model Name		ESC4000-E11
Networking		2 x Gigabit LAN ports (Intel® I350) 1 x Dedicated Management port
VGA		AST2600 64MB
Graphics		Up to 4 dual-slot or 8 single-slot GPU cards
Front I/O ports		4 x USB 3.2 Gen 1 ports
Rear I/O ports		2 x USB 3.2 Gen 1 ports 2 x Gigabit LAN ports (RJ45) 1 x Management port (RJ45) 1 x VGA port
Switch/LED		<b>Front Switch/LED:</b> 1 x Power Switch/LED 1 x Location Switch/LED 1 x Message LED 1 x Q-Code/Port 80 LED 2 x LAN LED  <b>Rear Switch/LED:</b> 1 x Power switch/LED 1 x Location LED 1 x Message LED
Security		TPM-SPI module (optional) PFR module (optional)
OS Support		Windows® Server, RedHat®, SuSE®, CentOS, Ubuntu, Vmware  * Refer to <a href="https://www.asus.com/event/Server/OS_support_list/OS.html">https://www.asus.com/event/Server/OS_support_list/OS.html</a> for the latest supported OS list
Management Solution	Out of Band Remote Hardware	On-Board ASMB11-iKVM for KVM-over-IP
	Software	ASUS Control Center
Regulatory Compliance		BSMI, CB, CE, FCC (Class A)
Dimension		800mm x 439.5mm x 88.9mm (2U air cooled) 845.45mm x 439.5mm x 88.9mm (2U immersion cooled)
Net Weight Kg		26 kg (excluding CPU, DRAM, and HDD)
Gross Weight Kg		36 kg (including packing, excluding CPU, DRAM, and HDD)
Power Supply		1+1 Redundant 2600W 80 PLUS Titanium CRPS-R Power Supply
Environment		Operation temperature: 10° ~ 35° Non-operation temperature: -40° ~ 70° Non-operation humidity: 20% ~ 90% (Non-condensing)



Always use PSUs with the same watt and power rating. Combining PSUs with different wattage (e.g. 1 x 2200 W + 1 x 2600 W) may yield unstable results and potential damage to your system.



Specifications are subject to change without notice.

# 1.4 Front panel features

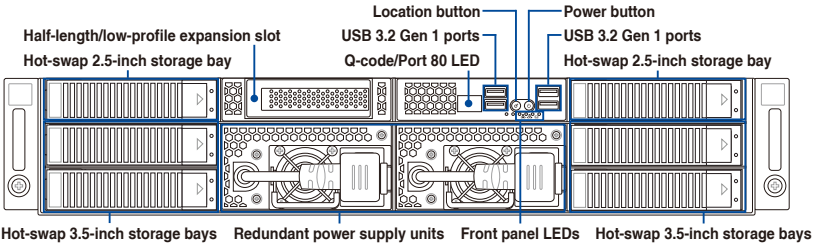

Refer to the **Front panel LEDs** section for the LED descriptions.

# 1.5 Rear panel features

## Air-cooled SKU

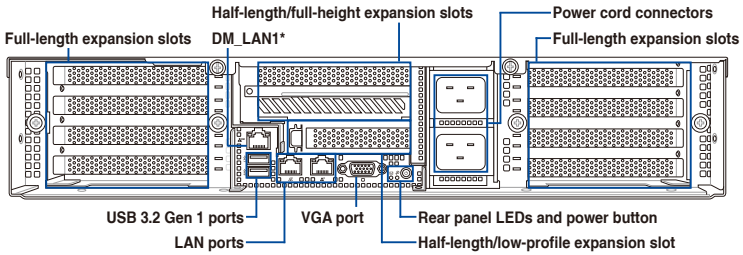

## Liquid-cooled SKU

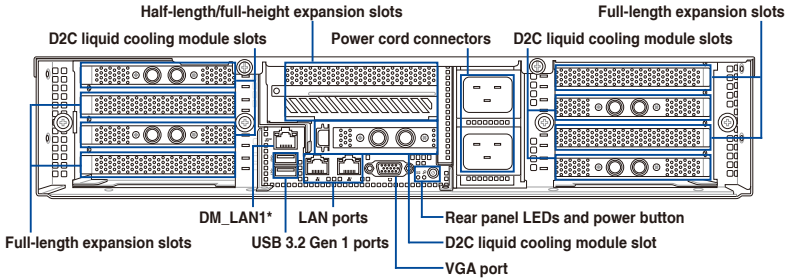

- The rear I/O ports do not appear on the rear panel if motherboard is not present.
- The DM\_LAN1 port is for ASUS ASMB11-iKVM controller only.
- The D2C liquid cooling module slots require a Liquid-to-Air Coolant Distribution Unit.
- Refer to the **Rear panel LEDs** section for the LED descriptions.



## 1.6 Internal features

The barebone server includes the basic components as shown.

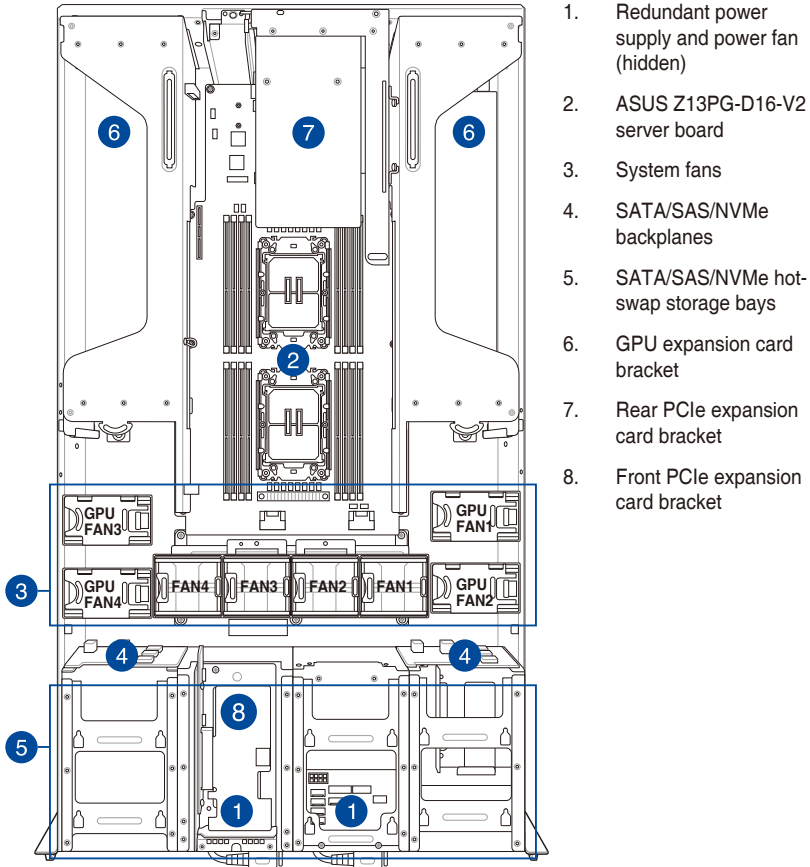

A protection film is pre-attached to the front cover before shipping. Please remove the protection film before turning on the system for proper heat dissipation.

### WARNING

HAZARDOUS MOVING PARTS  
KEEP FINGERS AND OTHER BODY PARTS AWAY

# 1.7 LED information

## 1.7.1 Front panel LEDs

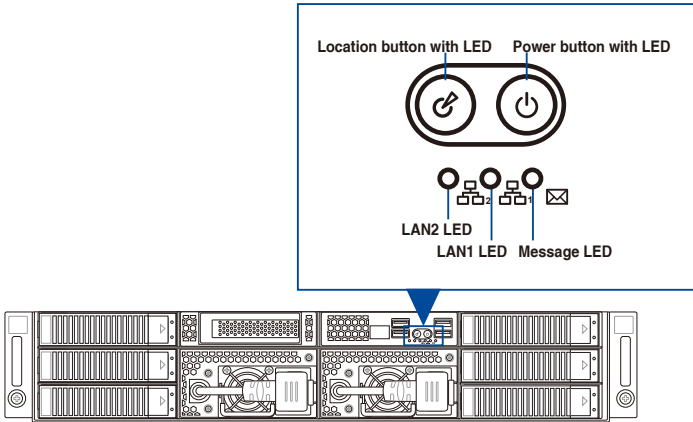

LED	Status	Description
Power LED	ON	System power is on
Location LED	OFF	System is normal; no incoming event
	ON	Received user command to locate the system
Message LED	OFF	System is normal; no incoming event
	ON	A hardware monitor event is indicated
LAN LEDs	OFF	No LAN connection
	Blinking	LAN is transmitting or receiving data
	ON	LAN connection is present

### 1.7.2 Rear panel LEDs

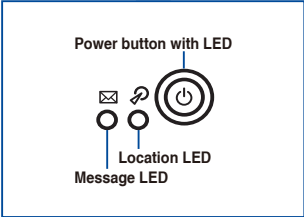
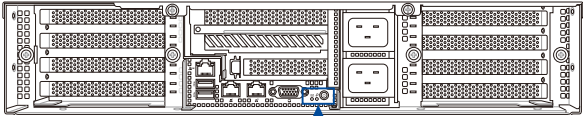

LED	Status	Description
Power LED	ON	System power is on
Location LED	OFF	System is normal; no incoming event
	ON	Received user command to locate the system
Message LED	OFF	System is normal; no incoming event
	ON	A hardware monitor event is indicated

### 1.7.3 LAN (RJ-45) LEDs

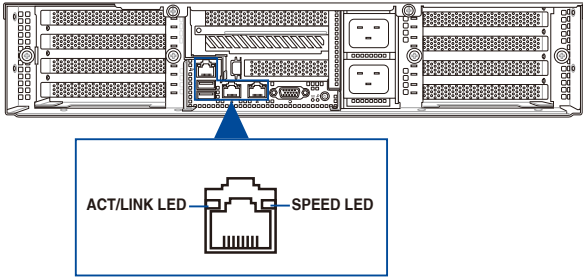

#### LAN1/LAN2 LEDs

ACT/LINK LED		SPEED LED	
Status	Description	Status	Description
OFF	No link	OFF	10 Mbps connection
GREEN	Linked	ORANGE	100 Mbps connection
BLINKING	Data activity	GREEN	1 Gbps connection

#### Dedicated Management LAN (for ASMB11 and DM\_LAN1)

ACT/LINK LED		SPEED LED	
Status	Description	Status	Description
OFF	No link	OFF	10 Mbps connection
ORANGE	Linked	ORANGE	100 Mbps connection
BLINKING	Data activity	GREEN	1 Gbps connection

## 1.7.4 HDD status LEDs

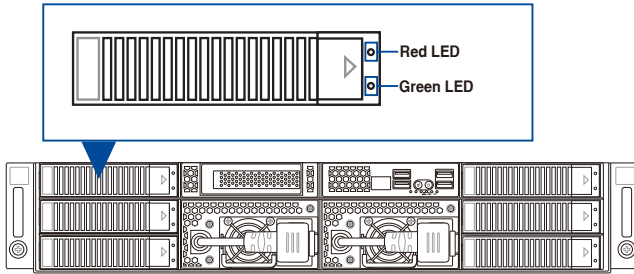

Storage Device LED Description		
Status (RED)	ON	Storage device has failed
	Blinking	RAID rebuilding or locating
Activity (GREEN)	ON	Storage device power ON
	Blinking	SATA/SAS/NVMe storage device reading or writing data
	OFF	Storage device not found



# Hardware Setup

# 2

This chapter lists the hardware setup procedures that you have to perform when installing or removing system components.

## 2.1 Chassis cover



The diagrams in this section are for reference only. The system layout may vary with models, but the installation steps are the same for all models.

To remove the rear chassis cover:

1. Loosen the two (2) thumbscrews on the rear of the chassis.
2. Push and hold the cover buttons down, then slide the chassis cover towards the rear to disengage it from the chassis.
3. Lift the chassis cover to completely remove it from the chassis.

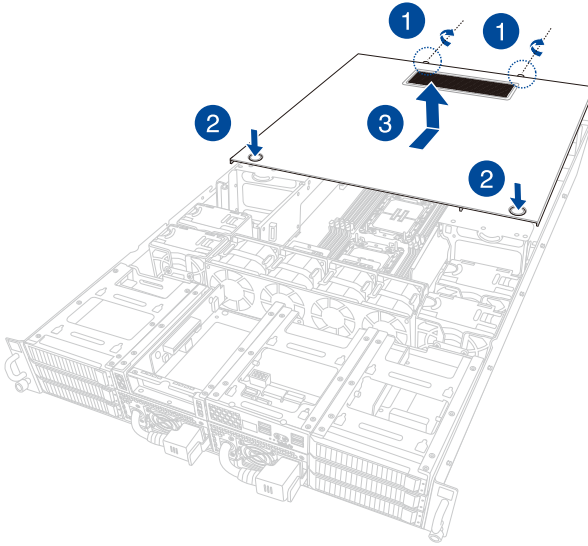



To remove the middle chassis cover:

1. Remove the two screws as shown.
2. Press the cover latches down on both sides of the middle chassis cover.
3. Lift the chassis cover to completely remove it from the chassis.

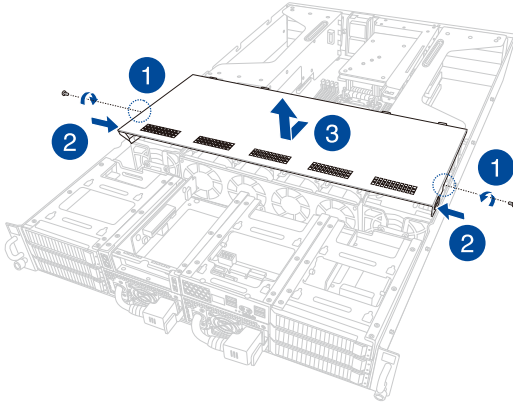

To remove the front chassis cover:

1. Push and hold the cover buttons down, then slide the chassis cover towards the front to disengage it from the chassis.
2. Lift the chassis cover to completely remove it from the chassis.

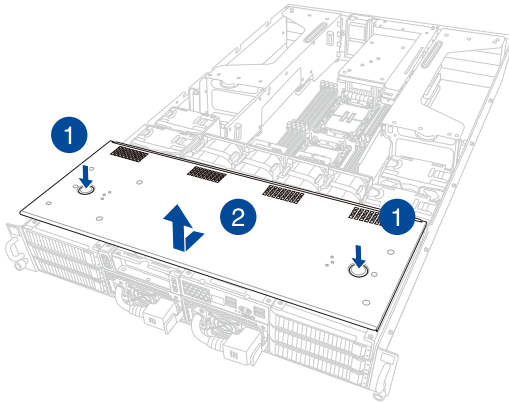

A protection film is pre-attached to the system cover before shipping. Please remove the protection film before turning on the system for proper heat dissipation.

## 2.1.1 Air duct



The diagrams in this section are for reference only. The system layout may vary with models, but the installation steps are the same for all models.

To remove the air duct:

1. Loosen the two thumbscrews as shown.
2. Lift the air duct to remove it from the chassis.

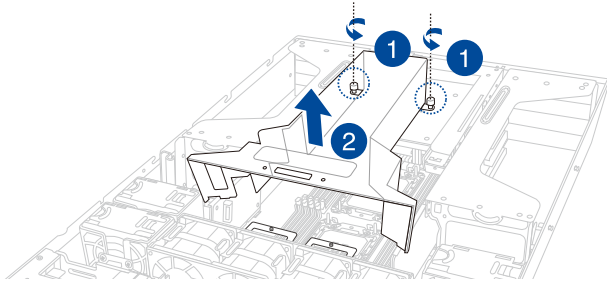

To reinstall the air duct:

1. Align and install the air duct to the chassis ensuring that the screw holes on the air duct match the screw holes on the chassis.
2. Tighten the two thumbscrews to secure the air duct.

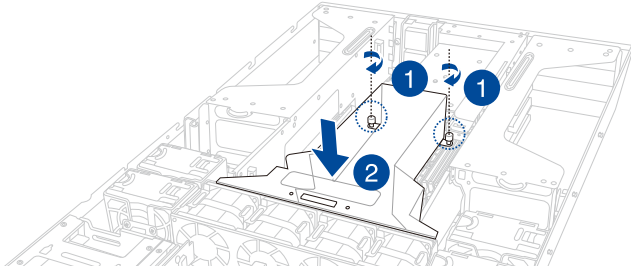

## 2.2 Central Processing Unit (CPU)

The motherboard comes with two surface mount LGA 4677 sockets designed for the 4<sup>th</sup> Gen Intel<sup>®</sup> Xeon<sup>®</sup> Scalable Processors Family Series.



- Upon purchase of the motherboard, ensure that the PnP cap is on the socket and the socket contacts are not bent. Contact your retailer immediately if the PnP cap is missing, or if you see any damage to the PnP cap/socket contacts/motherboard components. ASUS will bear the cost of repair only if the damage is shipment/transit-related.
- Keep the cap after installing the motherboard. ASUS will process Return Merchandise Authorization (RMA) requests only if the motherboard comes with the PnP cap on the socket.
- The product warranty does not cover damage to the socket contacts resulting from incorrect CPU installation/removal, or misplacement/loss/incorrect removal of the PnP cap.

### 2.2.1 Installing the CPU and heatsink

1. Remove the rear chassis cover. For more information, see the **Chassis cover** section.
2. Remove the air duct. For more information, see the **Air Duct** section.
3. Locate the CPU socket on the motherboard.

#### Z13PG-D16 CPU LGA 4677 Socket

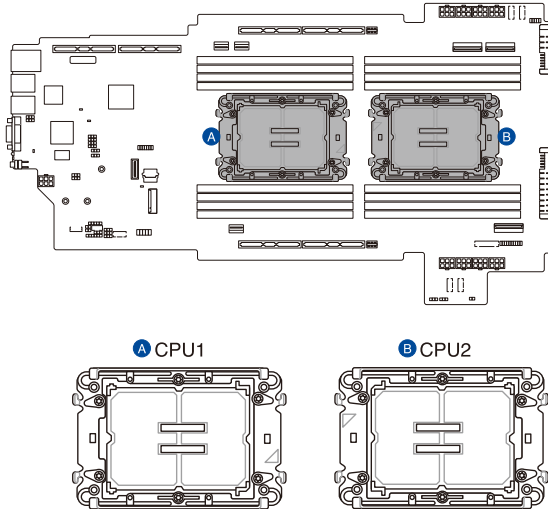

4. Remove the PnP caps from the CPU sockets.



---

Keep the PnP cap. ASUS will process Return Merchandise Authorization (RMA) requests only if the motherboard comes with the PnP cap on the socket.

---

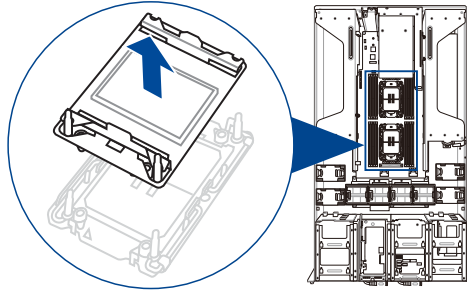

5. Attach the CPU to the carrier bracket, ensure the triangle mark is on the same side as the bracket lever, then attach the CPU and carrier bracket to the heatsink.



---

The CPU carrier differs depending on the type of CPU. Ensure that the CPU carrier corresponds to the CPU being installed.

---

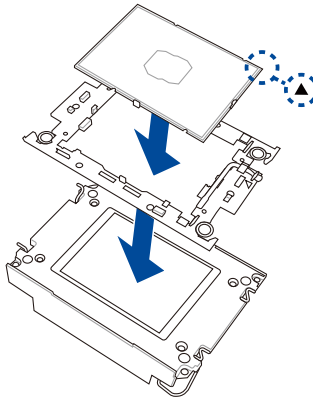

6. Align the CPU and heatsink assembly in the correct orientation so that the triangle marks on both the CPU and socket are aligned in the same direction, then place the heatsinks on top of the CPU sockets.



---

The CPU and CPU Carrier fits in only one correct orientation. DO NOT force the CPU and CPU Carrier into the socket to prevent damaging the CPU pins on the socket.

---

7. Once the heatsink is placed on top of the CPU socket (A), push the lock latches outwards on all four corners of the heatsink so that the heatsink and CPU assembly is secured to the CPU socket (B).



---

Ensure the triangle mark on the CPU is located in the same corner as the CPU socket.

---

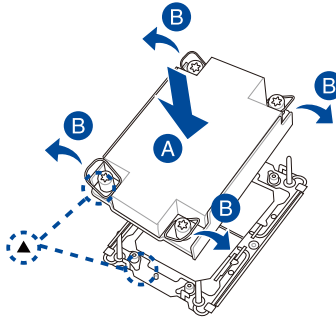

8. Do two clockwise turns on each of the heatsink screws in the cross order pattern shown below until the heatsink screws are tightened and the heatsink is secured onto the motherboard.



---

Intel® recommends a using a torque driver with a T-30 bit and a torque value of 8 lbf-in to prolong the longevity of all PEEK nuts after the quality of the load post is corrected.

---

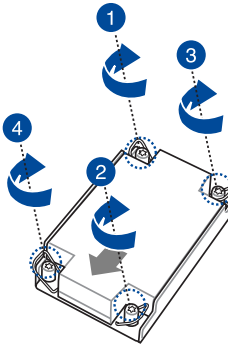

9. Reinstall the air duct. For more information, see the **Air duct** section.

## 2.2.2 Installing the CPU and liquid cooling module

1. Remove the screw securing the PCIe riser card to the chassis.
2. Firmly hold the riser card, then pull it up to detach it from the PCIe slot on the motherboard.

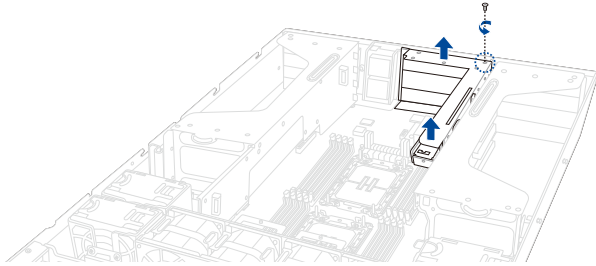

3. Refer to steps 1 to 5 in the previous section to install the CPU into the liquid cooling module.
4. Align and place the liquid cooling module assembly in the correct orientation as shown in the illustration below, then secure the PCIe riser card with the screw you removed earlier.

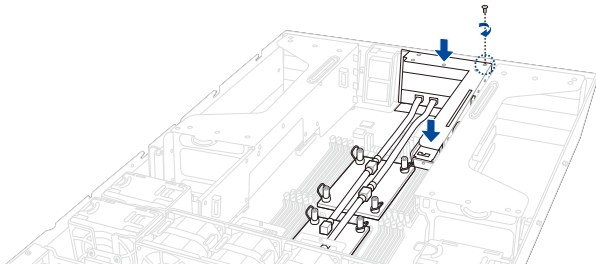

5. Refer to steps 7 to 8 in the previous section to secure the liquid cooling module.
6. Connect the leak detection sensor cable to **WL\_CON1** on the motherboard.

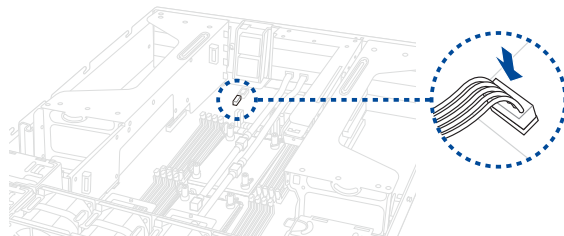

## 2.3 System memory

### 2.3.1 Overview

The motherboard comes with sixteen (16) Double Data Rate 5 (DDR5) Dual Inline Memory Module (DIMM) sockets.

The figure illustrates the location of the DDR5 DIMM sockets:

#### Z13PG-D16 288-pin DDR5 DIMM sockets

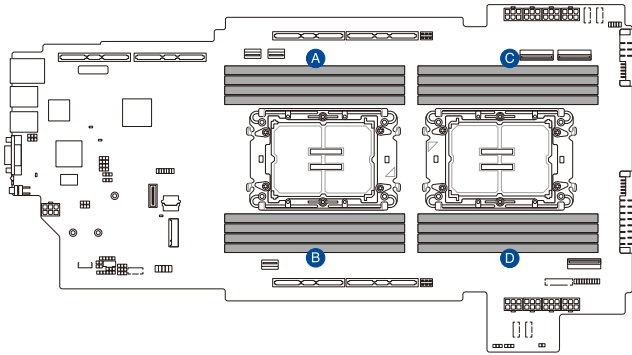

**A** CPU1\_DIMM\_H1  
CPU1\_DIMM\_G1  
CPU1\_DIMM\_F1  
CPU1\_DIMM\_E1

**B** CPU1\_DIMM\_A1  
CPU1\_DIMM\_B1  
CPU1\_DIMM\_C1  
CPU1\_DIMM\_D1

**C** CPU2\_DIMM\_D1  
CPU2\_DIMM\_C1  
CPU2\_DIMM\_B1  
CPU2\_DIMM\_A1

**D** CPU2\_DIMM\_E1  
CPU2\_DIMM\_F1  
CPU2\_DIMM\_G1  
CPU2\_DIMM\_H1

### 2.3.2 Memory configurations

You may install 16 GB, 32 GB, 64 GB DDR5 RDIMM / 128 GB, 256 GB DDR5 3DS RDIMM into the DIMM sockets using the memory configurations in this section.



- Refer to ASUS Server AVL for the updated list of compatible DIMMs.
- Always install DIMMs with the same CAS latency. For optimum compatibility, it is recommended that you obtain memory modules from the same vendor.

Dual CPU configuration																
CPU	CPU1								CPU2							
Slot	A1	B1	C1	D1	E1	F1	G1	H1	A1	B1	C1	D1	E1	F1	G1	H1
2 DIMMs	•								•							
4 DIMMs	•						•		•						•	
8 DIMMs	•		•		•		•		•		•		•		•	
12 DIMMs	•		•	•	•	•	•		•		•	•	•	•	•	
16 DIMMs	•	•	•	•	•	•	•	•	•	•	•	•	•	•	•	•

### 2.3.3 Installing a DIMM



Make sure to unplug the power supply before adding or removing DIMMs or other system components. Failure to do so may cause severe damage to both the motherboard and the components.

1. Unlock a DIMM socket by pressing the retaining clips outward.
2. Align a DIMM on the socket such that the notch on the DIMM matches the DIMM slot key on the socket.

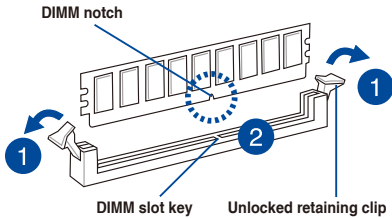

A DIMM is keyed with a notch so that it fits in only one direction. To avoid damaging the DIMM, DO NOT force a DIMM into a socket in the wrong direction.



3. Hold the DIMM by both of its ends, then insert the DIMM vertically into the socket. Apply force to both ends of the DIMM simultaneously until the retaining clips snap back into place.

Ensure that the DIMM is sitting firmly on the DIMM slot.

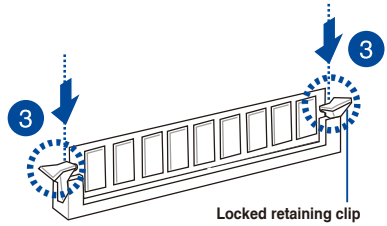

Always insert the DIMM into the socket VERTICALLY to prevent DIMM notch damage.

### 2.3.4 Removing a DIMM

1. Simultaneously press the retaining clips outward to unlock the DIMM.
2. Remove the DIMM from the socket.

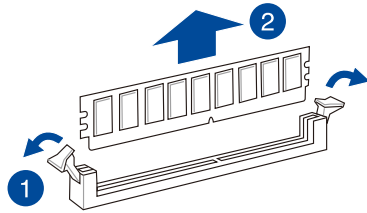

Support the DIMM lightly with your fingers when pressing the retaining clips. The DIMM might get damaged when it flips out with extra force.

## 2.4 Storage devices

The chassis supports the following storage configurations:

- 2 x 2.5-inch storage devices and 4 x 3.5-inch storage devices
- 6 x 2.5-inch storage devices

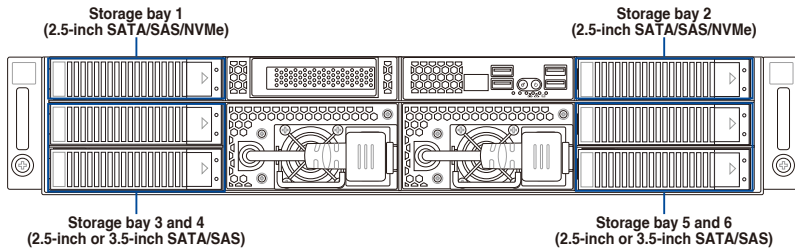

### 2.4.1 Installing a 3.5-inch storage device.

1. Press the spring lock to release the tray lever and partially eject the tray from the bay.

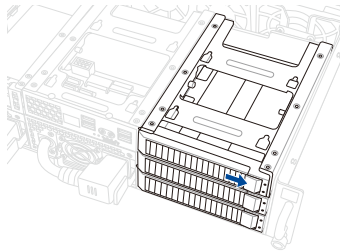

2. Firmly hold the tray lever and carefully pull the drive tray out of the bay.

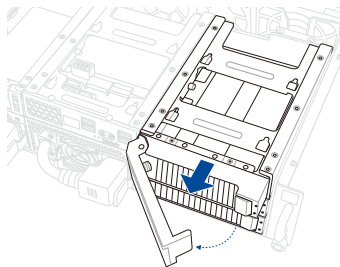

3. Insert the 3.5-inch storage device into the tray until it clicks into place.

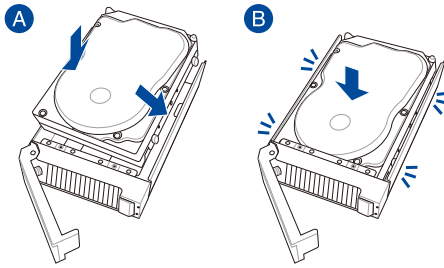

4. Align and insert the 3.5-inch storage device and drive tray assembly into the drive bay.

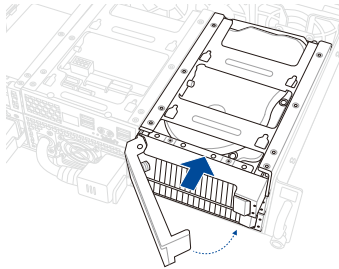

5. Repeat steps 1 to 4 to install additional 3.5-inch storage devices.

## 2.4.2 Installing a 2.5-inch storage device.

To install 2.5-inch storage devices into storage bays 1 and 2:

1. Remove the drive tray.



---

Refer to the **Installing a 3.5-inch storage device** section to remove the drive tray.

---

2. Push the tool-less 2.5-inch tray through the openings on the bottom of the drive tray.

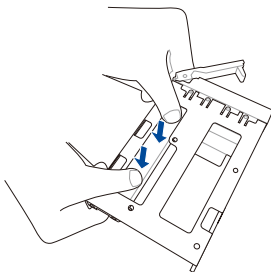

3. Prepare the 2.5-inch storage device, then insert it into the tool-less 2.5" tray.

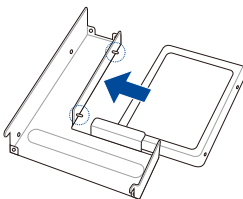

4. Insert the tool-less 2.5-inch tray into the drive tray until it clicks in place.

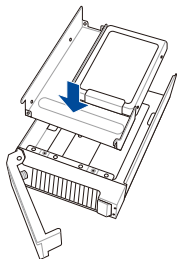

5. Align and insert the 2.5-inch storage device and drive tray assembly into the drive bay.
6. Repeat steps 1 to 5 to install additional 2.5-inch storage devices.

**To install 2.5-inch storage devices into storage bays 3, 4, 5, and 6:**

1. Remove the drive tray.



---

Refer to the **Installing a 3.5-inch storage device** section to remove the drive tray.

---

2. Align and install the 2.5-inch storage device into the drive tray and secure it with four screws.

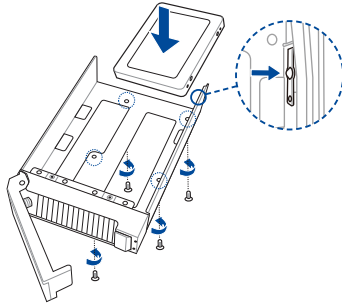

---

The tool-less notch may interfere when trying to align the screw holes. Press the storage device against the notch if you are experiencing issues trying to align the screw holes.

---

3. Align and insert the 2.5-inch storage device and drive tray assembly into the drive bay.
4. Repeat steps 1 to 3 to install additional 2.5-inch storage devices.

## 2.5 Expansion slots



Make sure to unplug the power cord before adding or removing expansion cards. Failure to do so may cause you physical injury and damage motherboard components.

### 2.5.1 Installing a PCIe expansion card

The onboard PCI Express slot on the motherboard comes pre-installed with a riser card that supports two x16 slots (1 x Gen5 x16 link, 1 x Gen5 x8/x16 link) for full-height/half-length PCIe cards.



If a 10GbE PCIe network adapter is installed, it is recommended to connect external power directly to the power supply units on the front panel, and not via the power socket on the rear panel.

To install PCIe expansion cards to the riser card:

1. Remove the screw, then firmly hold the riser card and pull upwards to detach it from the PCIe slot on the motherboard.

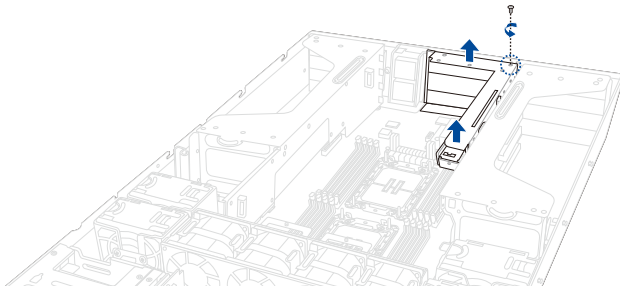

2. Remove the screw from the PCIe lock on the riser card, then remove the PCIe lock from the riser card.

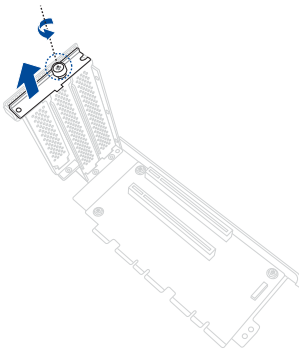

3. Remove the metal covers from the riser card.

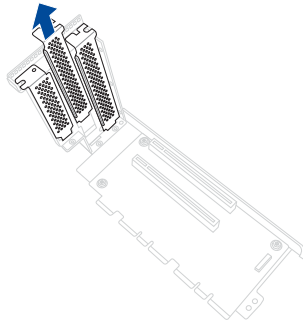

4. Prepare the expansion cards.



---

Before installing an expansion card, read the documentation that came with it and ensure that the proper hardware settings are configured.

---

5. Align and insert the golden finger connectors of the expansion cards into the PCIe slot connectors on the riser card as shown.

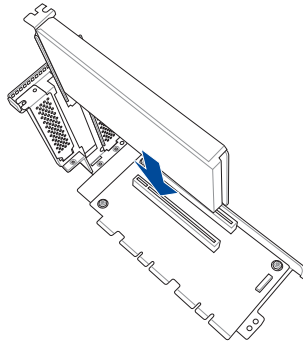

6. Replace the metal covers for any unused PCIe slots, then secure the PCIe lock using the screw removed earlier.

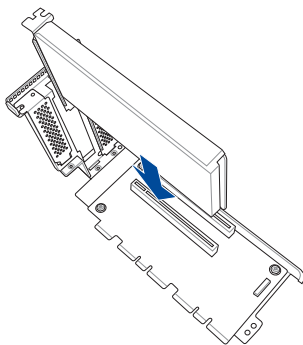

7. Align and insert the riser card and expansion card assembly into the PCIe slot on the motherboard.

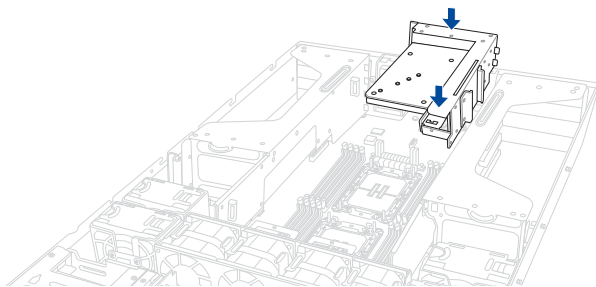



## 2.5.2 Installing a PIKE II or RAID card

A PIKE II or RAID card can be installed in the internal SAS/HBA/Storage bracket located in the front of the system.

1. Remove the four system fans as shown.



---

Refer to the **Removable/Optional Components** section for the steps on removing the system fans.

---

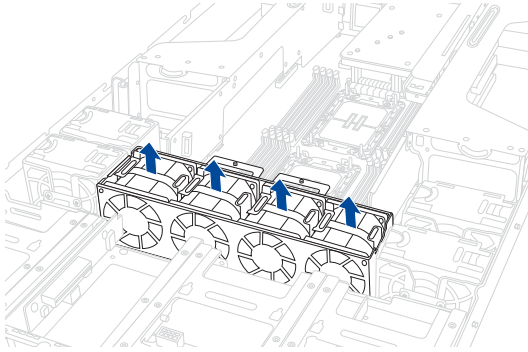

2. Remove the four screws from the fan cage as shown.

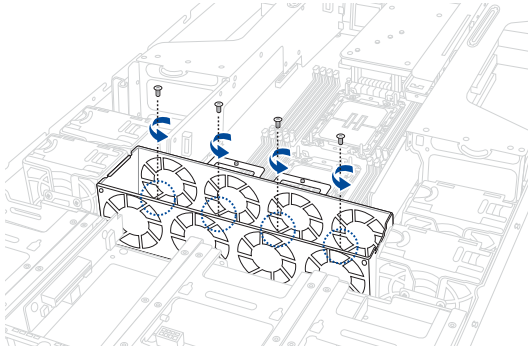

3. Remove the fan cage from the system chassis.

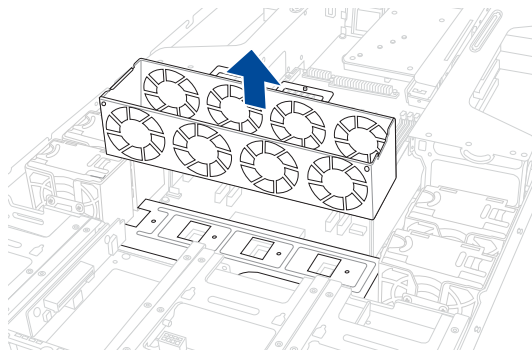

4. Remove the ten screws as shown, then remove the two fans and fan cages from the system chassis.

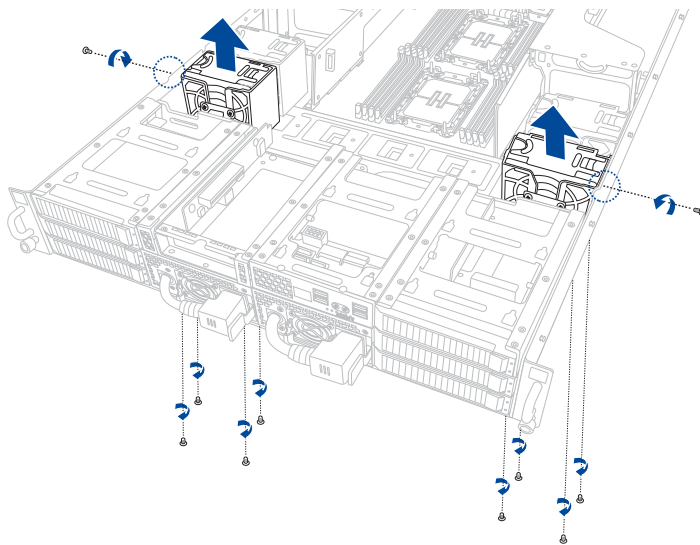

5. Remove the two screws from the internal bracket as shown.

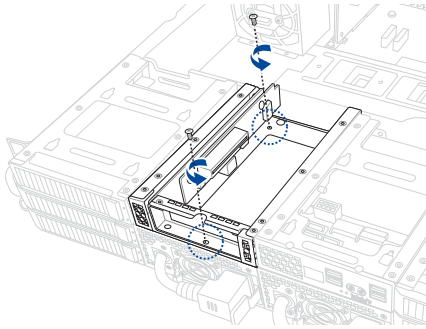

6. Remove the screw from the metal cover, then remove the metal cover.

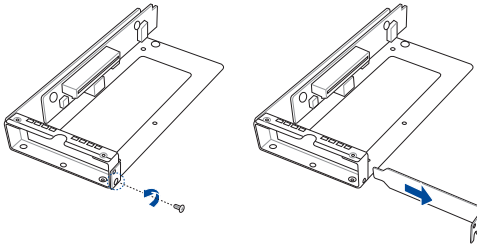

7. (Optional) To install an ASUS PIKE II 3108 RAID card and cache vault, follow the below instructions to install the cache vault add-on card:

a. Align the two spacers with the screw holes on the ASUS PIKE II card, then secure the two spacers with two screws from the bottom of the card.

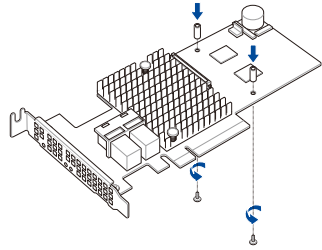

b. Align and install the bundled cache vault add-on card onto the connector on the ASUS PIKE II card, then secure it to the two spacers with two screws.

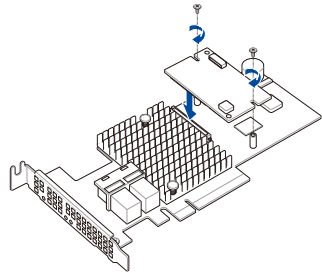

c. Connect the bundled power cable to the cache vault add-on card.

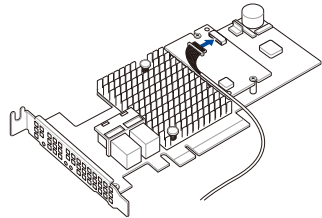

8. Insert the PIKE II or RAID card into the internal bracket, then secure it using the screw you removed earlier.

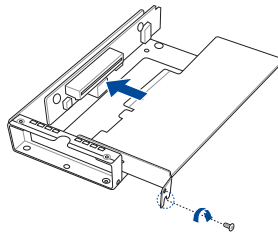

9. Refer to the below instructions to connect the PIKE II or RAID card:

**To connect a PIKE II 3008 / PIKE II 3108 card:**

- a. Disconnect the default SLIMSAS cables connected to **SLIMSAS1** on the left and right backplanes.

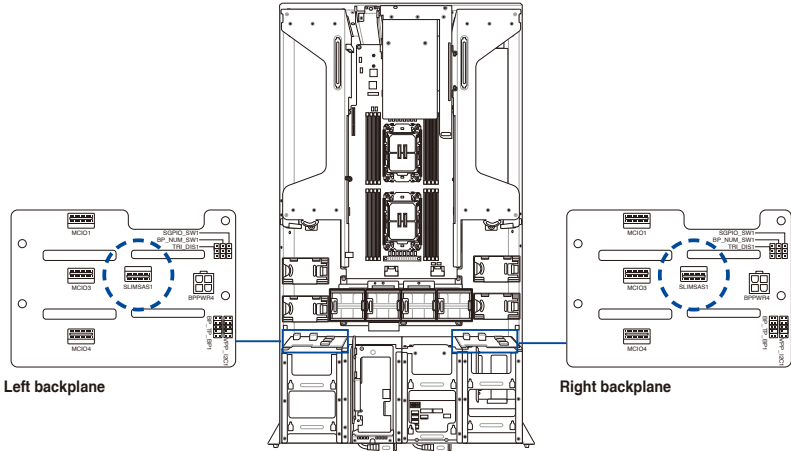

- b. Connect the upper MiniSAS (ISAS1) connector (B) on the PIKE II card to **SLIMSAS1** on the right backplane using the bundled cables.
- c. Connect the lower MiniSAS (ESAS1) connector (C) on the PIKE II card to **SLIMSAS1** on the left backplane using the bundled cables.

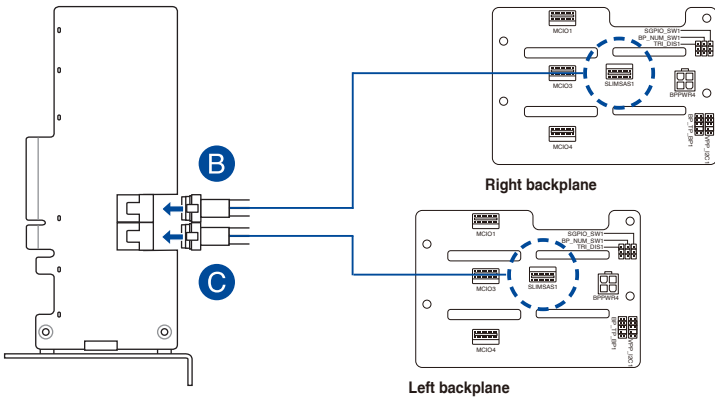

**To connect a 9540 RAID card in NVME configuration:**

- a. Connect the SLIMSAS connector on the RAID card to **MCIO3** and **MCIO4** on the left backplane using the bundled cables.

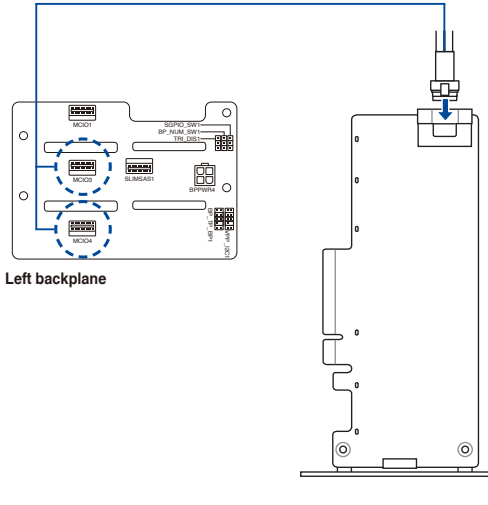

**To connect a 9540 RAID card in SATA configuration:**

- a. Disconnect the default SLIMSAS cables connected to **SLIMSAS1** on the left and right backplanes.

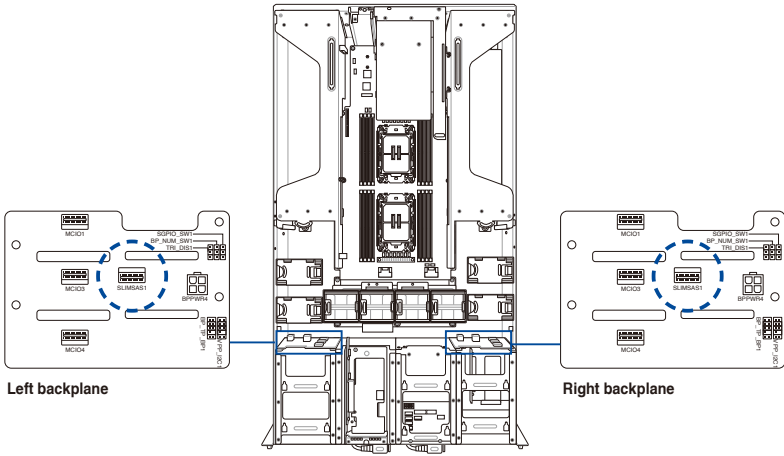

- b. Connect the SLIMSAS connector on the RAID card to **SLIMSAS1** on the left and right backplanes using the bundled cables.

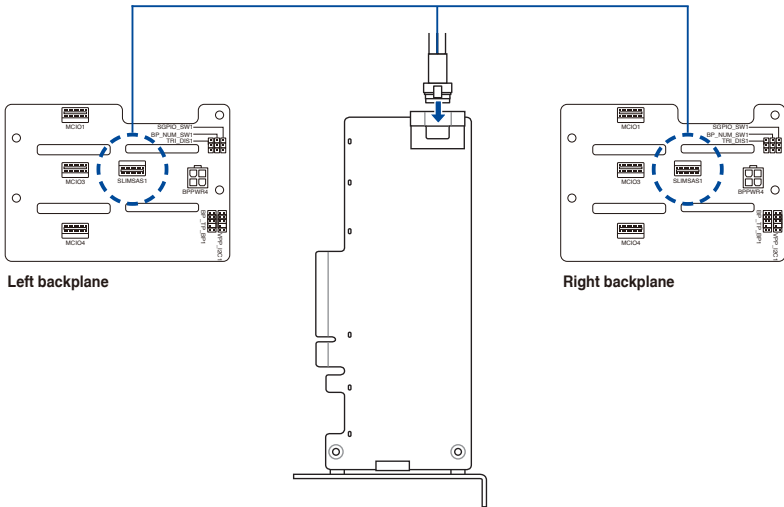

**To connect a 9560 RAID card in NVME configuration:**

- a. Disconnect the default MCIO cables connected to **MCIO3** and **MCIO4** on the right backplane.

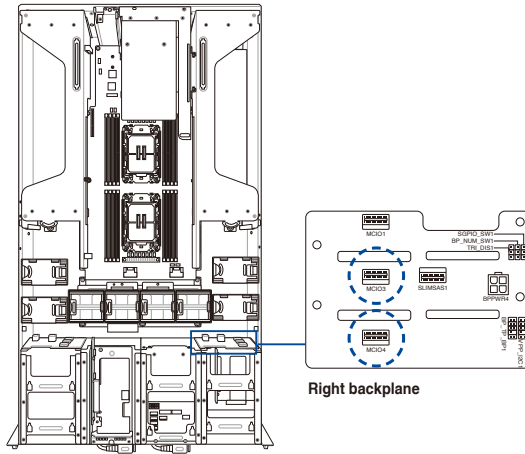

- b. Connect the left SLIMSAS connector (B) on the RAID card to **MCIO3** and **MCIO4** on the left backplane using the bundled cables.
- c. Connect the right SLIMSAS connector (C) on the RAID card to **MCIO3** and **MCIO4** on the right backplane using the bundled cables.

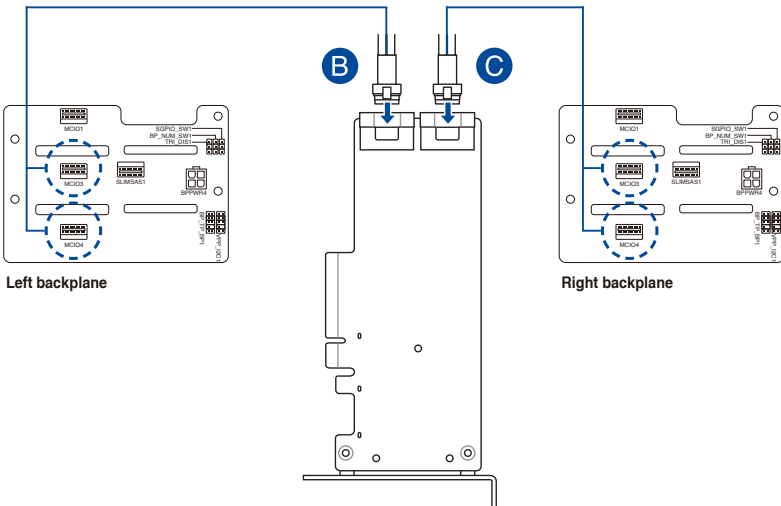



**To connect a 9560 RAID card in SATA configuration:**

- a. Disconnect the default SLIMSAS cables connected to **SLIMSAS1** on the left and right backplanes.

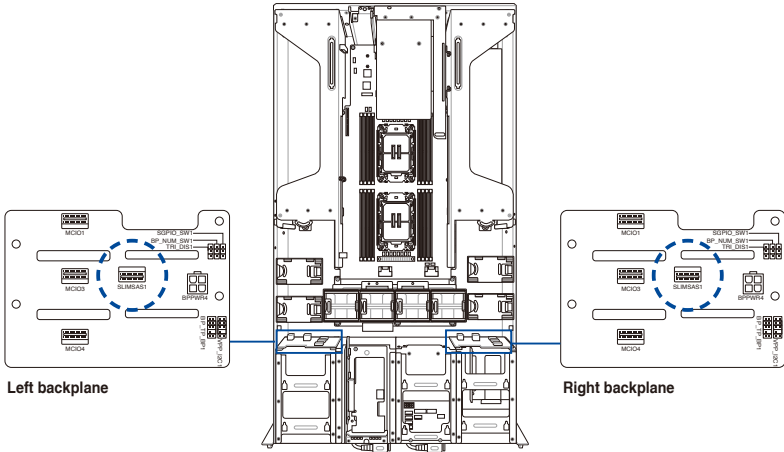

- b. Connect the left SLIMSAS connector (B) on the RAID card to **MCI03** and **MCI04** on the left backplane using the bundled cables.
- c. Connect the right SLIMSAS connector (C) on the RAID card to **MCI03** and **MCI04** on the right backplane using the bundled cables.

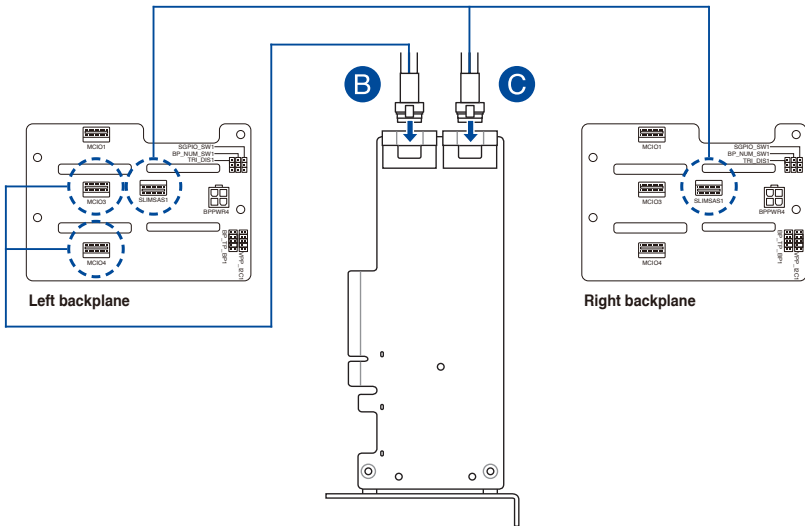

10. Secure the internal bracket using the screws you removed earlier.

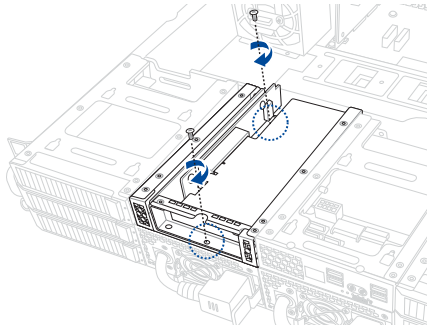

11. (Optional) Refer to the **Installing the Cache Vault Power Module** section to install and connect the Cache Vault Power Module.



---

The cache vault is required for the PIKE II 3108 card or the 9560 RAID card.

---

12. Align and install the fans and fan cages, then secure the fan cages using the screws you removed earlier.

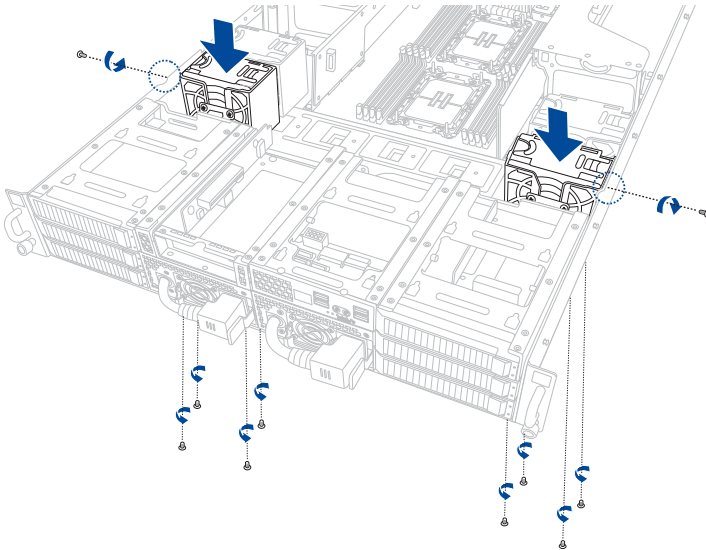

13. Align and install the fan cage, then secure it using the screws you removed earlier.

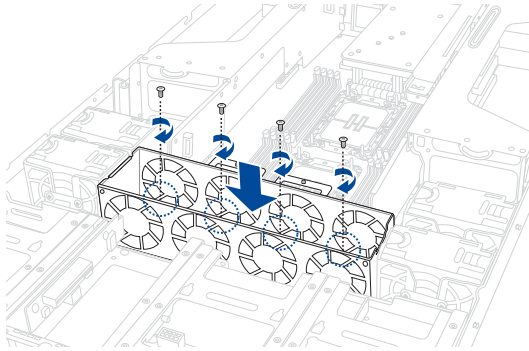

14. Install the system fans into the fan cage.

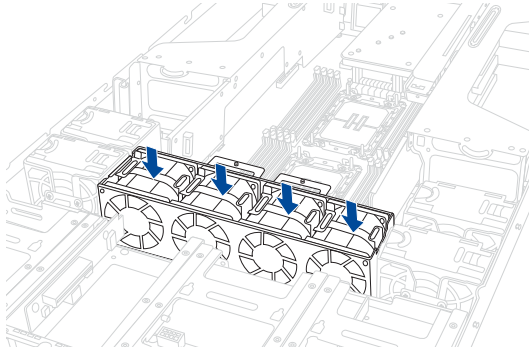

## 2.5.3 Installing the Cache Vault Power Module

1. Disconnect the three cables from the Front Panel Module, then remove the two screws.

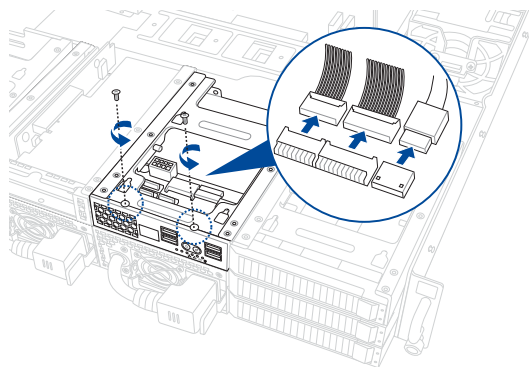

2. From the back of the Front Panel Module, push the Front Panel Module out of the system.

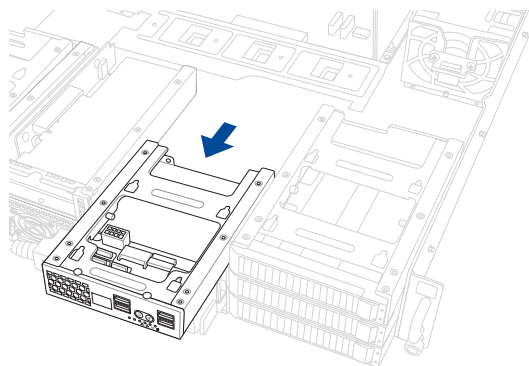

3. Align the three screw holes on the Cache Vault Power Module clip with the three screw holes on the Front Panel Module, then secure the clip with the three bundled screws.

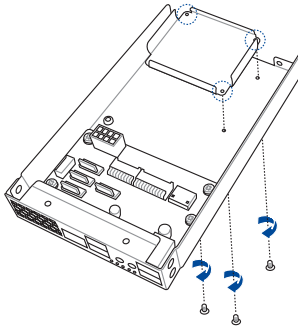

4. Align and install the Cache Vault Power Module into the Cache Vault Power Module clip.

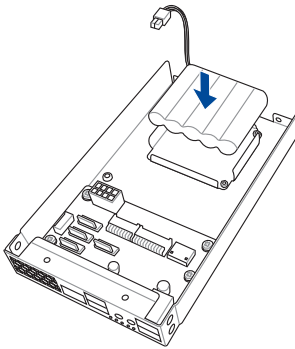

5. Insert the Front Panel Module into the system.

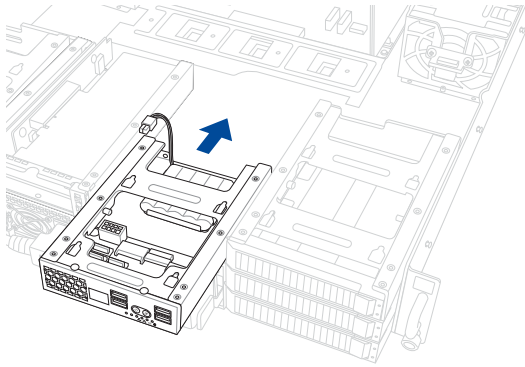

6. Connect the Cache Vault Power Module to the PIKE II card or RAID card.
7. Reconnect the three cables to the Front Panel Module, then secure the Front Panel Module using the two screws you removed earlier.



---

When reconnecting the cables, ensure that the cables are not placed on top of the Cache Vault Power Module.

---

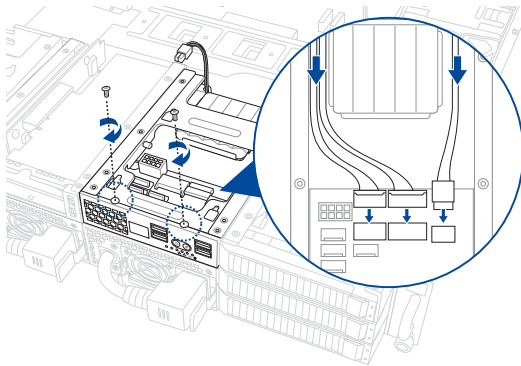

## 2.5.4 Installing an M.2 (NGFF) card

You may install an M.2 card (up to 22110) to the PCIe 5.0 M.2 card.

1. Remove the four (4) cover screws that secure the cover to the PCIe 5.0 M.2 card, then remove the cover and set it aside.

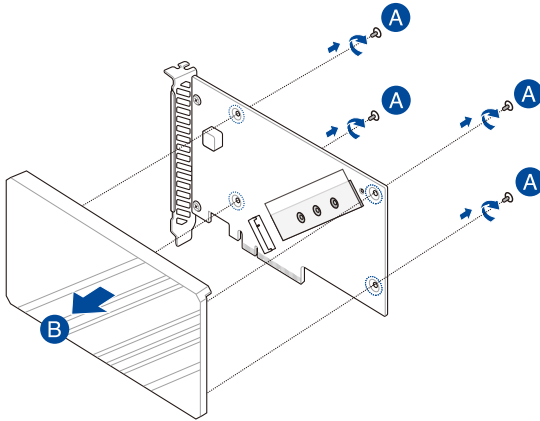

2. Peel the plastic film off the thermal pad next to the M.2 slot.

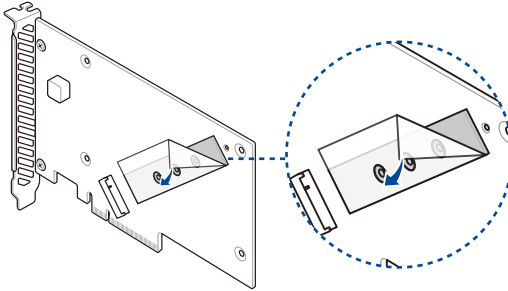

3. Secure the bundled stand screw onto the PCIe 5.0 M.2 card.

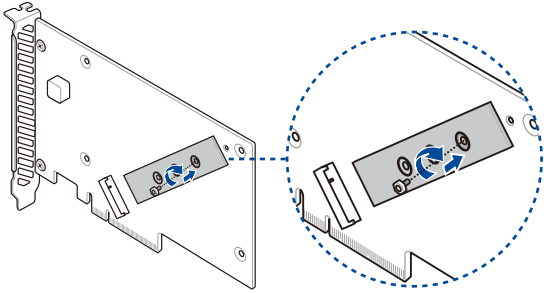

4. Install the M.2 storage device into the onboard M.2 slot (A), then secure the M.2 storage device with the bundled screw (B).

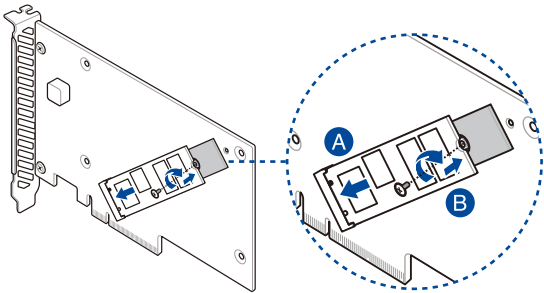

5. Peel the plastic film off the thermal pad on the heatsink (A), secure the cover onto the PCIe 5.0 M.2 card with the cover screws that you removed earlier (B), then install the PCIe 5.0 M.2 card into the PCIe slot on the rear riser card.

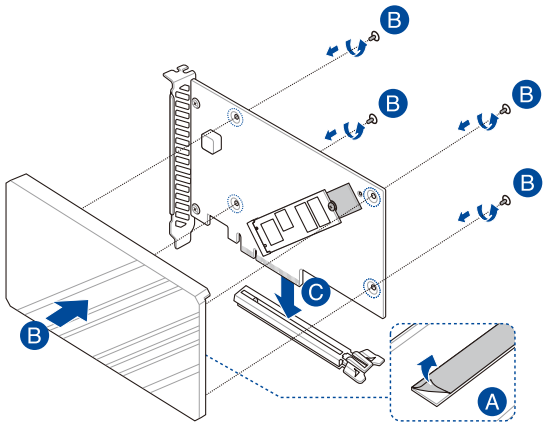



## 2.5.5 Configuring an expansion card

After installing the expansion card, configure it by adjusting the software settings.

1. Turn on the system and change the necessary BIOS settings, if any. Refer to the **BIOS Setup** chapter for information on BIOS setup.
2. Assign an IRQ to the card. Refer to the **Standard Interrupt assignments** table for more information.
3. Install the software drivers for the expansion card.

### Standard Interrupt assignments

IRQ	Priority	Standard function
0	1	System Timer
1	2	Keyboard Controller
2	-	Programmable Interrupt
3*	11	Communications Port (COM2)
4*	12	Communications Port (COM1)
5*	13	--
6	14	Floppy Disk Controller
7*	15	--
8	3	System CMOS/Real Time Clock
9*	4	ACPI Mode when used
10*	5	IRQ Holder for PCI Steering
11*	6	IRQ Holder for PCI Steering
12*	7	PS/2 Compatible Mouse Port
13	8	Numeric Data Processor
14*	9	Primary IDE Channel
15*	10	Secondary IDE Channel

\* These IRQs are usually available for ISA or PCI devices.

## 2.6 Cable connections



- The bundled system cables are pre-connected before shipment. You do not need to disconnect these cables unless you remove the pre-installed components to install additional devices.
- Refer to the **Motherboard Information** chapter for detailed information on the connectors.

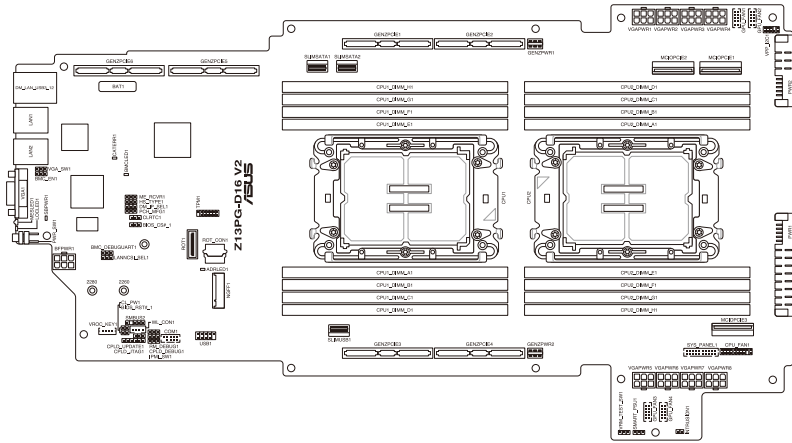

### Pre-connected system cables

1. PWR1 power connector (from the power distribution board to the motherboard)
2. SLIMSATA1-2 connectors (from the motherboard to the backplane board)
3. SLIMUSB1 connector (from the motherboard to the front I/O board)
4. MCIOPCIE1, MCIOPCIE2 connectors (from motherboard to the backplane board)
5. MCIOPCIE3 connector (from motherboard to the front riser board)
6. SYS\_PANEL1 connector (from the motherboard to the front I/O board)
7. CPU\_FAN1, GPU\_FAN1-4 fan connectors (from the motherboard to the system fans)
8. VPP\_I2C1 connector (from the motherboard to the backplane board)

## 2.7 SATA/SAS/NVMe backplane cabling

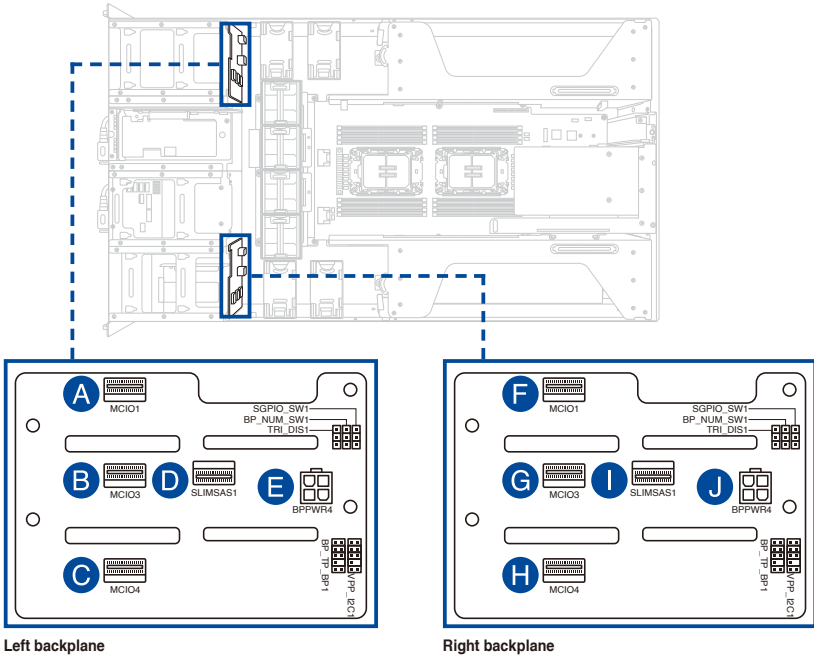

<b>A</b>	Connect MCIO1 on the left backplane to MCIOPCIE2 on the motherboard
<b>B</b>	Connect MCIO3 on the left backplane to MCIOPCIE3 on the motherboard
<b>C</b>	Connect MCIO4 on the left backplane to MCIOPCIE3 on the motherboard
<b>D</b>	Connect SLIMSAS1 on the left backplane to SLIMSATA1 on the motherboard
<b>E</b>	Connect BPPWR4 on the left backplane to BPPWR2 on the power distribution board
<b>F</b>	Connect MCIO1 on the right backplane to MCIOPCIE2 on the motherboard
<b>G</b>	Connect MCIO3 on the right backplane to MCIOPCIE1 on the motherboard
<b>H</b>	Connect MCIO4 on the right backplane to MCIOPCIE1 on the motherboard
<b>I</b>	Connect SLIMSAS1 on the right backplane to SLIMSATA2 on the motherboard
<b>J</b>	Connect BPPWR4 on the right backplane to BPPWR1 on the power distribution board

## 2.8 Removable/optional components

The following sections describe installation or removal instructions for the following removable/optional components:

1. System fans
2. Redundant power supply units
3. GPUs
4. GPU bridges
5. PFR module



---

Ensure that the system is turned off before removing any components.

---

### 2.8.1 System fans

To uninstall the system fans:

1. Hold the system fan by the notches, then press the latch inwards to release the system fan from the fan cage.
2. Lift the fan, then set it aside.

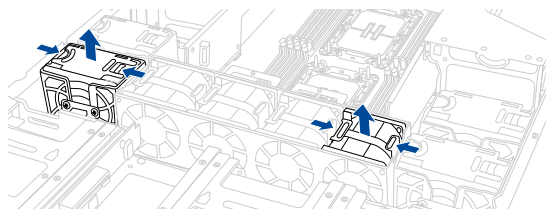

3. Repeat steps 1 to 2 to uninstall the other system fans.

To reinstall the system fans:

1. Insert the fan into the fan cage and ensure that it is securely seated.

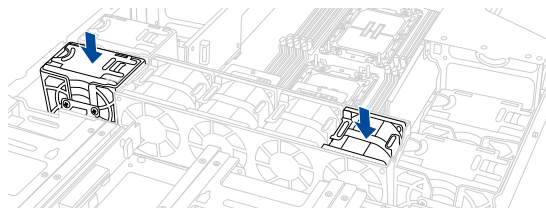

## 2.8.2 Redundant power supply units



We recommend that you use both of your hands when performing the following steps.

To replace a power supply unit (PSU):

1. Unplug the PSU power cable.

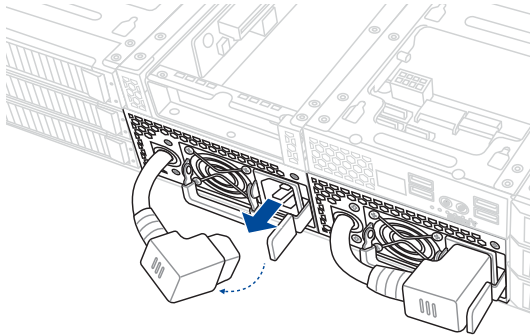

2. Lift up the PSU lever.
3. Hold the PSU lever, press the PSU latch (A), then carefully pull the PSU out of the system chassis (B).

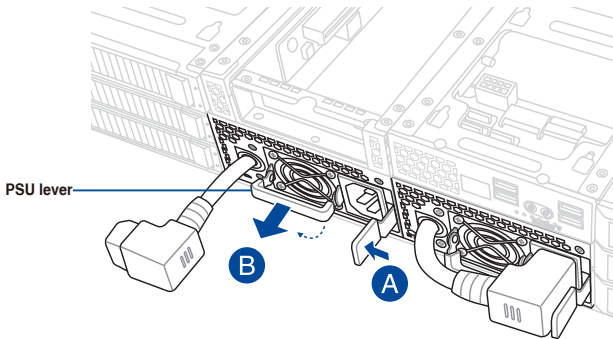

4. Prepare the replacement PSU.
5. Align and insert the replacement PSU into the empty PSU bay until it clicks in place.

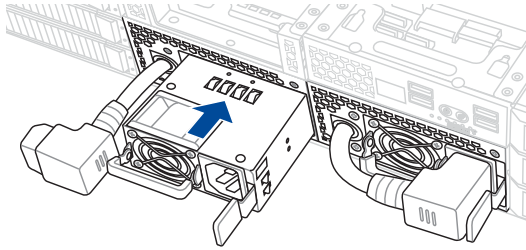

6. Reconnect the PSU power cable.

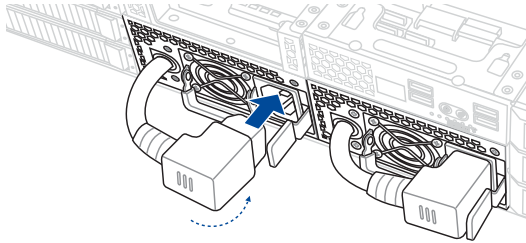

- The system automatically combines the two power supply modules into one. The combined output power varies with input voltages. Refer to the table below for details.

2600W (Air-cooled SKU)

Input Voltage	Max. Output Power (Watt) per PSU
100V-127Vac, 13.8A, 50/60Hz	1000W
220-240Vac, 16A, 50/60Hz	2600W

2600W (Liquid-cooled SKU)

Input Voltage	Max. Output Power (Watt) per PSU
220Vac, 16A, 50/60Hz	2600W

- To enable the hot-swap feature (redundant mode), keep the total power consumption of the system under the maximum output power of an individual power supply module.



- Always use PSUs with the same watt and power rating. Combining PSUs with different wattage (e.g. 1 x 1620 W + 1 x 2000 W) may yield unstable results and potential damage to your system.
- For a steady power input, use only the power cables that come with the server system package.

## 2.8.3 Installing a GPU

Follow the steps below to install a GPU card to the system.

1. Locate and loosen the three thumbscrews, then firmly hold and pull the GPU bracket upwards to detach it from the motherboard.

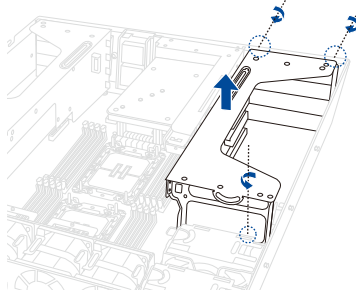

2. Prepare the appropriate GPU power cable depending on the type of GPU card.

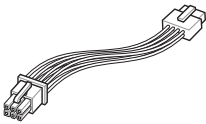

**Tesla/AMD**  
6pin to 8pin power cable

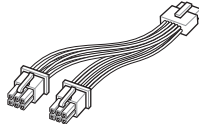

**Quadro**  
2x6pin to 8pin power cable

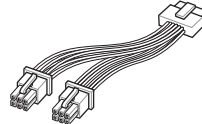

**12VHPWR**  
2x6pin to 12+4pin power cable

3. Install the air duct, if supported by the GPU card, and connect the GPU power cable.



The GPU air duct is designed and recommended for dual-slot GPU cards with a length of 10.5 inches.

### For GPU card installation with an air duct

Pass the power cable through the air duct and connect it to the GPU card, then secure the air duct to the GPU card with two screws.

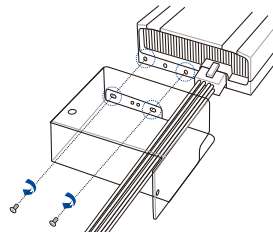

### For GPU card installation without an air duct

Connect the power cable to the GPU.

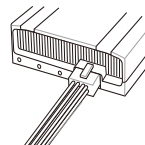

4. Place the GPU bracket on a flat and stable surface.
5. Loosen the two thumbscrews and remove the PCIe lock (A), then remove the metal covers (B).

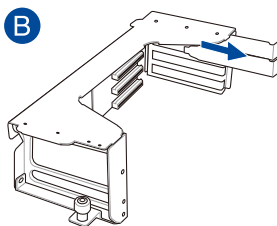
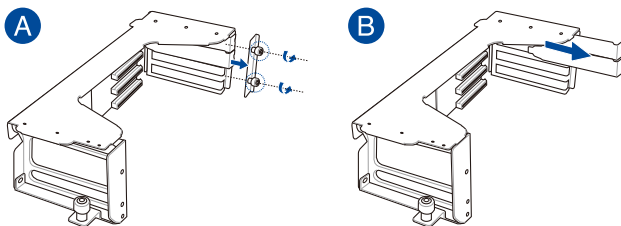

6. Insert the GPU cables into the opening on the GPU bracket.

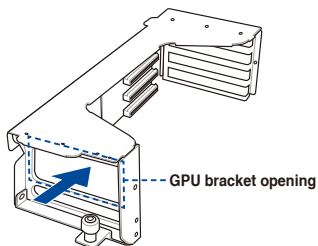



- Align and insert the golden fingers of the GPU card into the card slot on the bracket and ensure that it is securely seated in the slot.
- Secure the GPU card and air duct assembly to the GPU bracket.

**For GPU card installation with an air duct**

Secure the GPU card and air duct to the GPU bracket with a screw, then install the PCIe lock and secure the two thumbscrews.

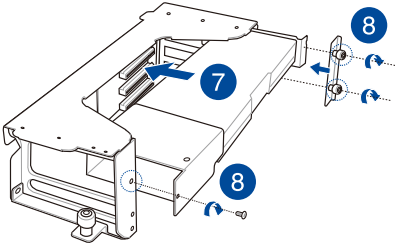

**For GPU card installation without an air duct**

Install the PCIe lock and secure the two thumbscrews.

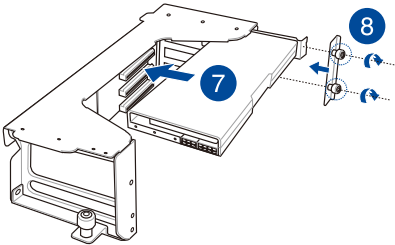

- Repeat steps 2 to 8 to install an additional GPU card to the bracket.

10. Align and insert the GPU bracket into the card slot on the motherboard and ensure that it is securely seated, then secure the three thumbscrews.

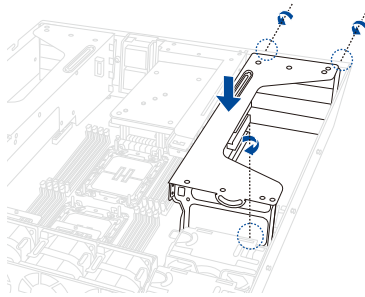

11. Connect the other end of the GPU power cable to an available 6-pin power connector in front of the GPU bracket.

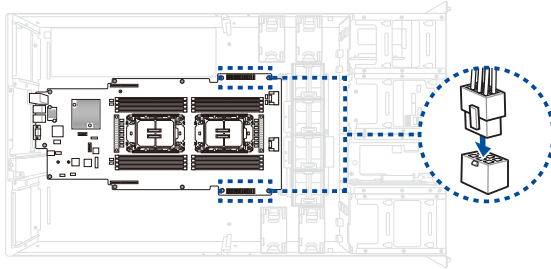

## 2.8.4 Installing a GPU liquid cooling module

Follow the steps below to install an optional liquid cooling module for supported GPU cards.

1. Remove the two screws, then remove the metal cover from the rear of the GPU bracket.

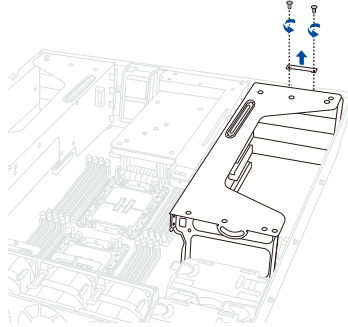

2. Locate and loosen the three thumbscrews, then firmly hold and pull the GPU bracket upwards to detach it from the motherboard.

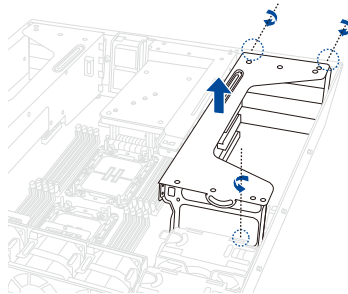

3. Place the GPU bracket on a flat and stable surface.
4. Loosen the two thumbscrews and remove the PCIe lock (A), then remove the metal covers (B).

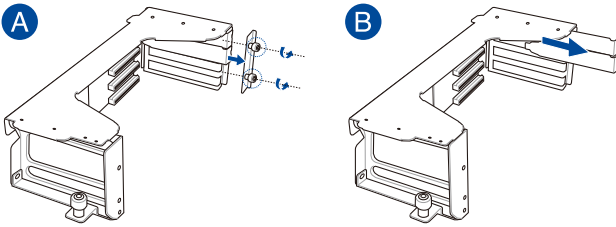

5. Connect the liquid cooling pipes to a supported GPU card.

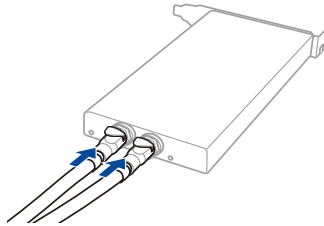

6. Install the liquid cooling pipe bracket, then secure it using two screws.

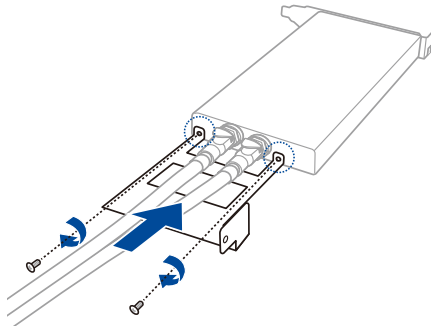

7. Push the latches on the liquid cooling pipes outwards (A), then use cable ties to secure the liquid cooling pipes (B).

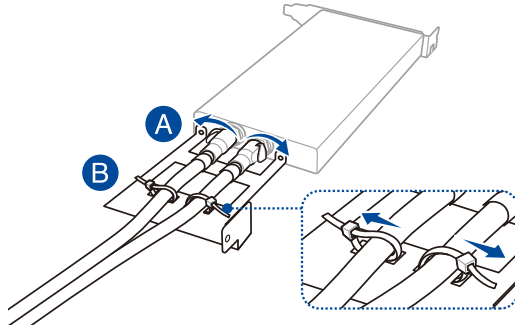

8. Install the GPU and liquid cooling assembly into the GPU bracket, then secure it using two screws.

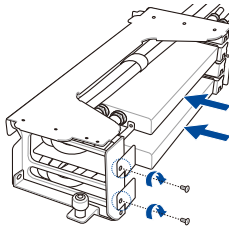

9. Install the PCIe lock, then secure the two thumbscrews.

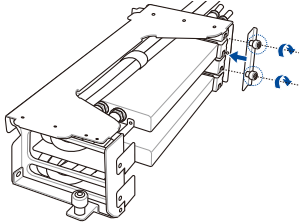

10. Align and insert the GPU bracket into the card slot on the motherboard and ensure that it is securely seated, then secure the three thumbscrews.

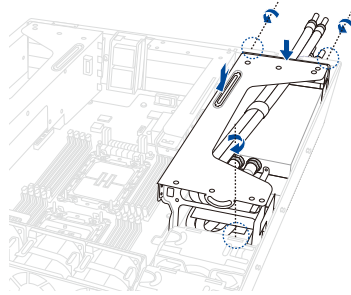

11. Install the metal cover, then secure it using two screws.

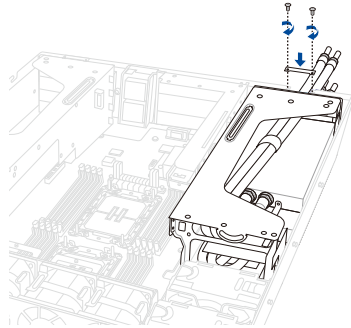

12. Connect the leak detection sensor cable to **WL\_CON3\_L** and **WL\_CON4\_L** for the left GPU bracket or **WL\_CON1\_R** and **WL\_CON2\_L** for the right GPU bracket.

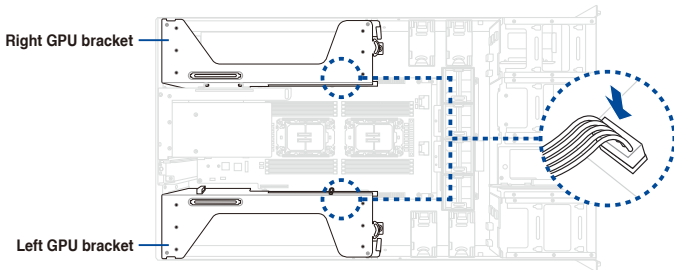

## 2.8.5 Installing a GPU bridge

Follow the steps below to install an optional GPU bridge to supported GPU cards.

### For AMD GPU cards with GPU bridge support

Align the GPU bridge with the golden finger connectors on the GPU cards, then install the GPU bridge.

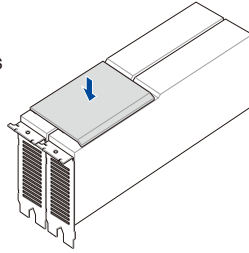

### For NVidia A100 GPU cards

Align the three GPU bridges with the golden finger connectors on the GPU cards, then install the GPU bridges.

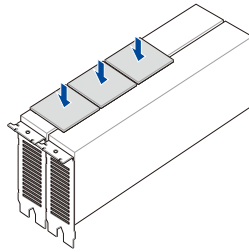

### For NVidia RTX A5000 / A6000 GPU cards

Align the GPU bridge with the golden finger connectors on the GPU cards, then install the GPU bridge.

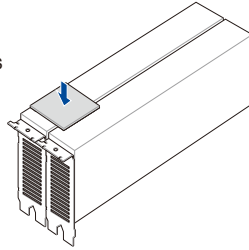

## 2.8.6 PFR module

The optional PFR module will come pre-installed on your system and is connected to the PFR module connector on your motherboard.



- The illustration below is for reference only.
- For more information or assistance, please refer to [www.asus.com](http://www.asus.com).

1. Locate the PFR module connector on your motherboard.

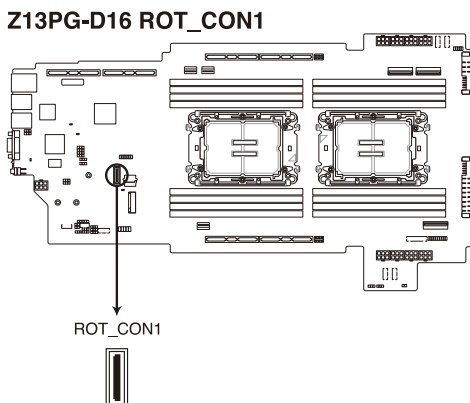

2. Align and connect the PFR module to the PFR module connector.

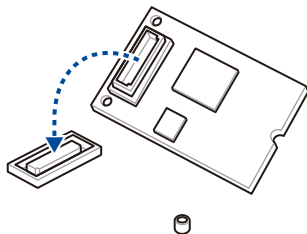

3. Push the PFR module down so that it is seated securely on the PFR module connector, then secure it using a screw.

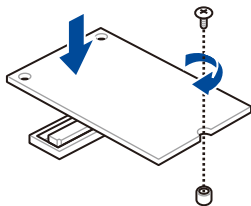



## 2.9 Rail kit options

This server system supports the rail kit options listed below. For more information on rail kit installation, refer to corresponding documentation on the ASUS support site or on the official product site for this server system.



- 
- We strongly recommend that at least two able-bodied persons perform the installation of the rail kit.
  - We recommend the use of an appropriate lifting tool or device, if necessary.
- 
- 1.5U full extension ball bearing rail kit



# Motherboard Information

This chapter gives information about the motherboard that comes with the server. This chapter includes the motherboard layout, jumper settings, and connector locations.

3

# 3.1 Motherboard layout

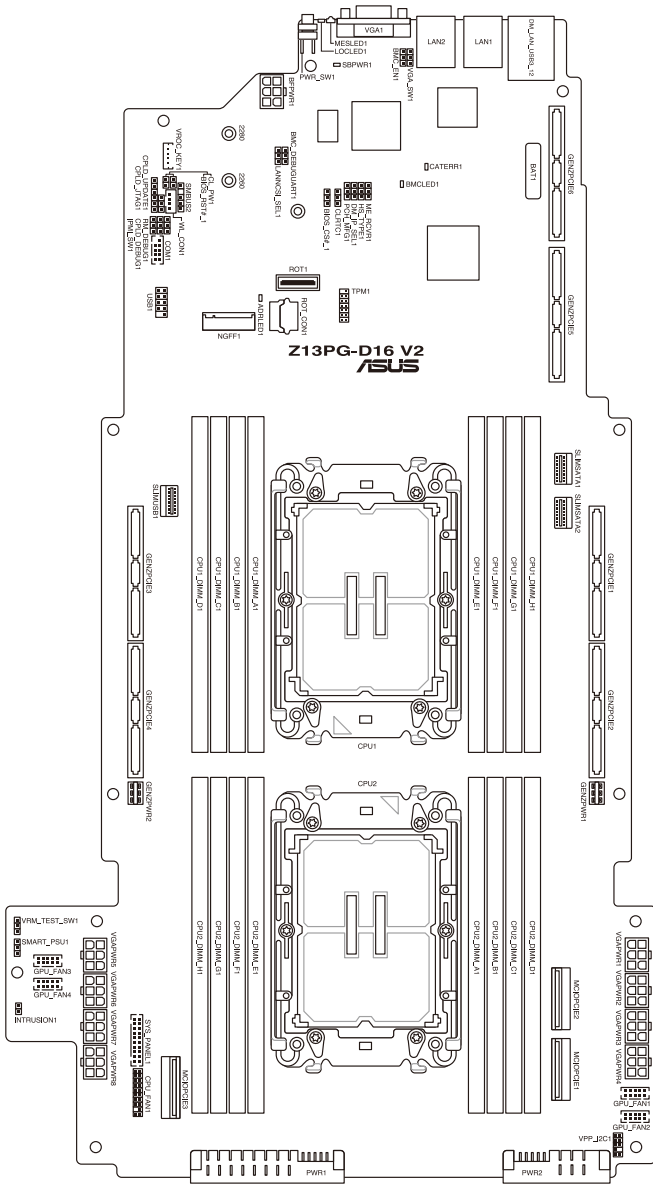

## Layout contents

Central Processing Unit (CPU)	Page
1. CPU socket(s)	3-4

Dual Inline Memory Module (DIMM)	Page
1. DIMM sockets	3-5

Jumpers	Page
1. Clear RTC RAM (3-pin CLRTC1)	3-6
2. VGA Controller setting (3-pin VGA_SW1)	3-7
3. Baseboard Management Controller setting (3-pin BMC_EN1)	3-7
4. DMLAN setting (3-pin DM_IP_SEL1)	3-8
5. IPMI SW setting (3-pin IPMI_SW1)	3-8
6. Heatsink Type setting (3-pin HS_TYPE1)	3-9
7. LANNCSI_SEL setting (3-pin LANNCSI_SEL1)	3-9
8. Smart Ride Through (SmaRT) setting (3-pin SMART_PSU1)	3-10

Internal connectors	Page
1. SLIMSATA connector (SLIMSATA1-2)	3-11
2. MCIOPCIE connectors (MCIOPCIE1-3)	3-11
3. USB 3.2 Gen 1 connectors (SLIMUSB1)	3-12
4. Chassis Intrusion (2-pin INTRUSION1)	3-12
5. Serial Port connector (10-1-pin COM1)	3-13
6. TPM connector (14-1-pin TPM1)	3-13
7. Power connector (PWR1-2)	3-14
8. VGA power connectors (6-pin VGAPWR1-8)	3-15
9. BF power connector (6-pin BFPWR1)	3-16
10. BMC debug UART connector (3-pin BMC_DEBUGUART1)	3-17
11. Platform Firmware Resilience (PFR) module connector (ROT_CON1)	3-17
12. System panel connector (20-pin SYS_PANEL1)	3-18
13. Leak detection sensor connector (4-pin WL_CON1)	3-19
14. VROC_KEY connector (4-pin VROC_KEY1)	3-19
15. M.2 (NGFF) connector (NGFF1)	3-20

Onboard LEDs		Page
1.	Standby Power LED (SBPWR1)	3-21
2.	Baseboard Management Controller LED (BMCLED1)	3-21
3.	Catastrophic Error LED (CATERR1)	3-22
4.	Message LED (MESLED1)	3-22
5.	Location LED (LOCLEL1)	3-23

## 3.2 Central Processing Unit (CPU)

The motherboard comes with two (2) surface mount LGA 4677 sockets designed for the 4<sup>th</sup> Gen Intel® Xeon® Scalable Processors Family series.

### Z13PG-D16 CPU LGA 4677 Socket

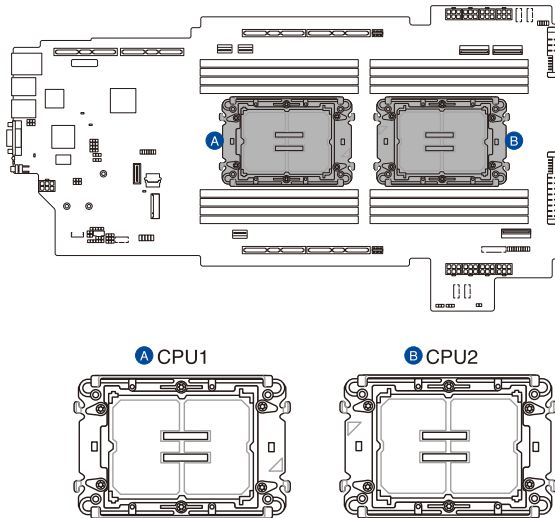

### 3.3 Dual Inline Memory Module (DIMM)

The motherboard comes with twelve (16) Double Data Rate 5 (DDR5) Dual Inline Memory Modules (DIMM) sockets.

#### Z13PG-D16 288-pin DDR5 DIMM sockets

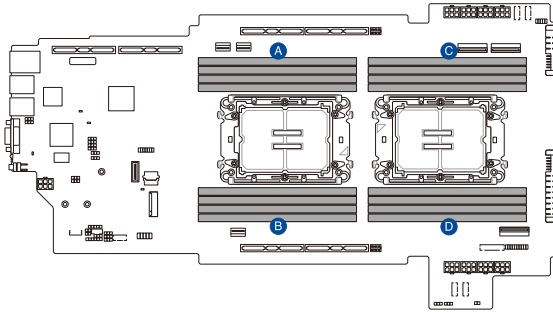

- A** CPU1\_DIMM\_H1  
CPU1\_DIMM\_G1  
CPU1\_DIMM\_F1  
CPU1\_DIMM\_E1
- B** CPU1\_DIMM\_A1  
CPU1\_DIMM\_B1  
CPU1\_DIMM\_C1  
CPU1\_DIMM\_D1
- C** CPU2\_DIMM\_D1  
CPU2\_DIMM\_C1  
CPU2\_DIMM\_B1  
CPU2\_DIMM\_A1
- D** CPU2\_DIMM\_E1  
CPU2\_DIMM\_F1  
CPU2\_DIMM\_G1  
CPU2\_DIMM\_H1

# 3.4 Jumpers

## 1. Clear RTC RAM (3-pin CLRTC1)

This jumper allows you to clear the CMOS memory system setup parameters by erasing the CMOS Real Time Clock (RTC) RAM data. The onboard button cell battery powers the RAM data in CMOS, which includes system setup information such as system passwords.

To erase the RTC RAM:

1. Turn OFF the computer and unplug the power cord.
2. Move the jumper cap from pins 1–2 (default) to pins 2–3. Keep the cap on pins 2–3 for about 5–10 seconds, then move the cap back to pins 1–2.
3. Plug the power cord and turn ON the computer.
4. Hold down the <Del> key during the boot process and enter BIOS setup to re-enter data.



Except when clearing the RTC RAM, never remove the cap on CLRTC jumper default position. Removing the cap will cause system boot failure!



If the steps above do not help, remove the onboard battery and move the jumper again to clear the CMOS RTC RAM data. After the CMOS is cleared, reinstall the battery.

### Z13PG-D16 CLRTC1

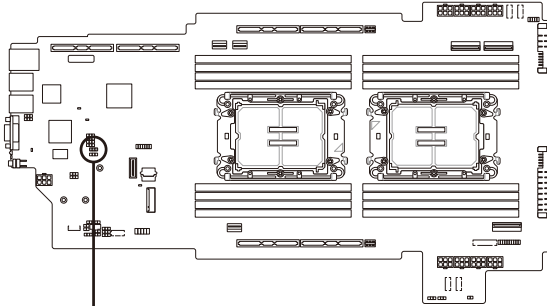

CLRTC1

1 2



Normal (Default)

2 3



Clear CMOS



## 2. VGA Controller setting (3-pin VGA\_SW1)

This jumper allows you to enable or disable the onboard VGA controller. Set to pins 1–2 to activate the VGA feature.

### Z13PG-D16 VGA\_SW1

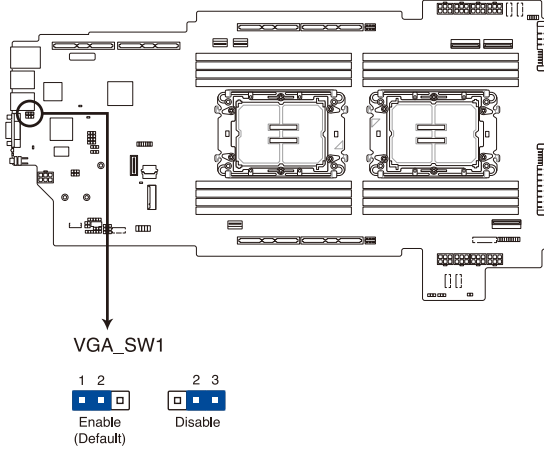

## 3. Baseboard Management Controller setting (3-pin BMC\_EN1)

This jumper allows you to enable (default) or disable on-board BMC. Ensure that this BMC jumper to enabled to avoid system fan control and hardware monitor error.

### Z13PG-D16 BMC\_EN1

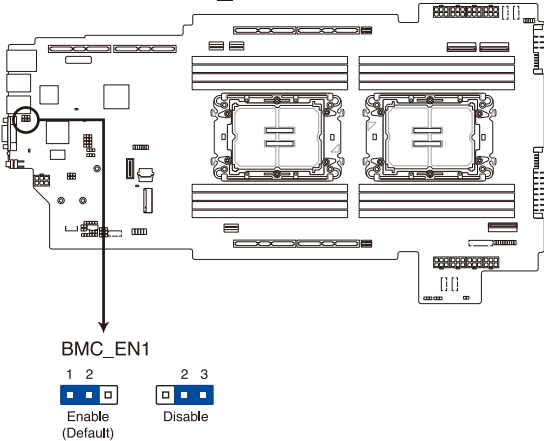

**4. DMLAN setting (3-pin DM\_IP\_SEL1)**

This jumper allows you to select the DMLAN setting. Set to pins 2-3 to force the DMLAN IP to static mode (IP=10.10.10.10, submask=255.255.255.0).

**Z13PG-D16 DM\_IP\_SEL1**

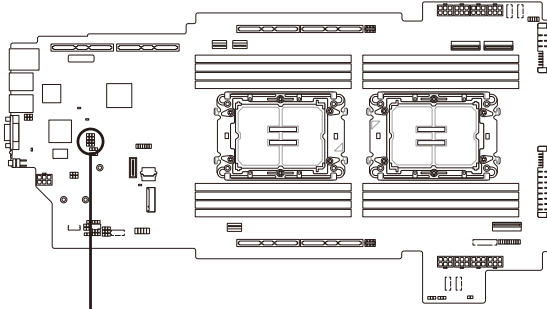

DM\_IP\_SEL1

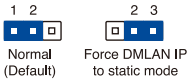

**5. IPMI SW setting (3-pin IPMI\_SW1)**

This jumper allows you to select which protocol in the GPU sensor to function.

**Z13PG-D16 IPMI\_SW1**

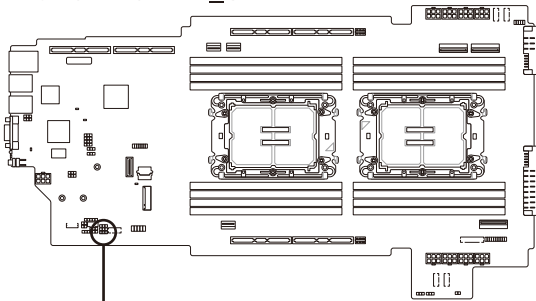

IPMI\_SW1



**6. Heatsink Type setting (3-pin HS\_TYPE1)**

This jumper allows you to set the fan curve used.

**Z13PG-D16 HS\_TYPE1**

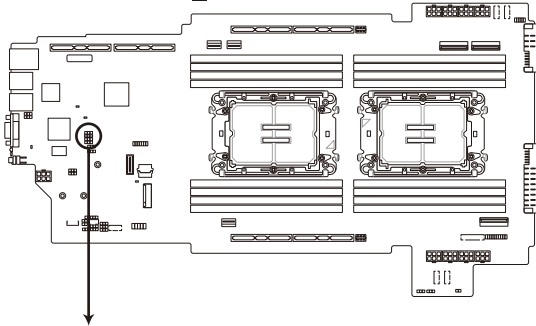

HS\_TYPE1

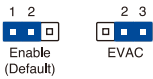

**7. LANNCSE setting (3-pin LANNCSE\_SEL1)**

This jumper allows you to select which LAN NCSI function to use.

**Z13PG-D16 LANNCSE\_SEL1**

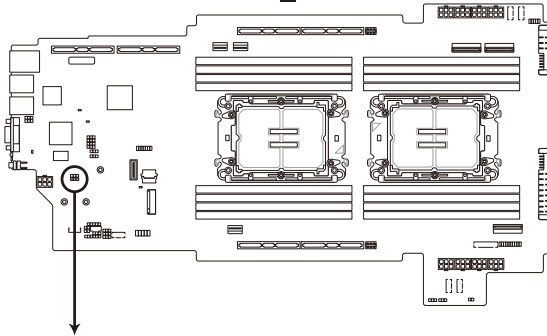

LANNCSE\_SEL1



**8. Smart Ride Through (SmaRT) setting (3-pin SMART\_PSU1)**

This jumper allows you to enable or disable the Smart Ride Through (SmaRT) function. This feature is enabled by default. Set to pins 2-3 to disable it. When enabled, SmaRT allows uninterrupted operation of the system during an AC loss event.

**Z13PG-D16 SMART\_PSU1**

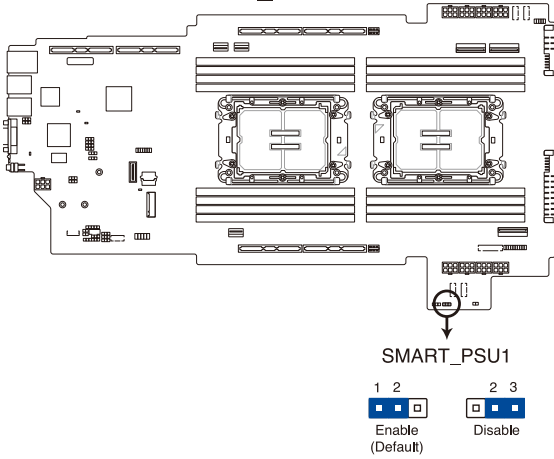

## 3.5 Internal connectors

### 1. SlimSATA connectors (SLIMSATA1-2)

Connects the SATA signal to the backplane.

#### Z13PG-D16 SLIMSATA

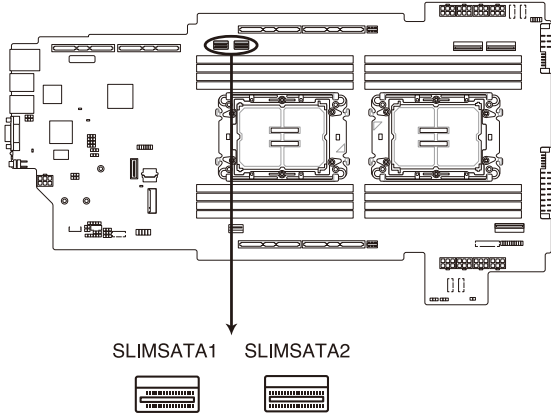

### 2. MCIOPCIE connectors (MCIOPCIE1-3)

Connects the PCIe signal to the backplane.

#### Z13PG-D16 MCIOPCIE connectors

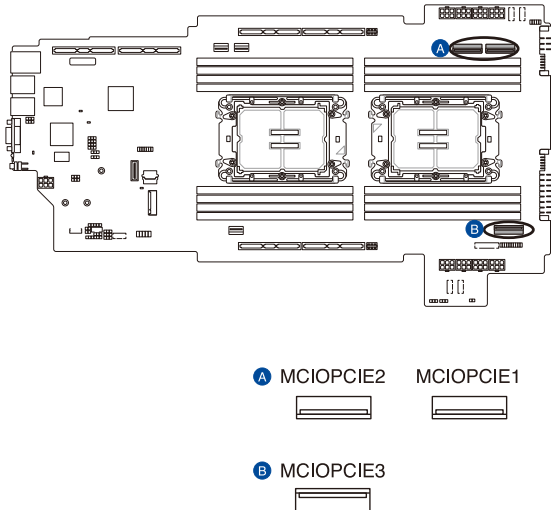

**3. USB 3.2 Gen 1 connectors (SLIMUSB1)**

Connect a compatible USB module cable to the SLIMUSB1 connector, and then install the module to a slot opening at the back or front of the system chassis. (SLIMUSB1 connector is used for the front USB panel by default).

**Z13PG-D16 SLIMUSB1**

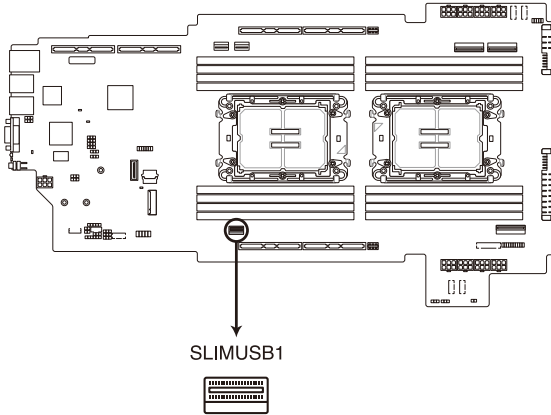

**4. Chassis Intrusion connector (2-pin INTRUSION1)**

These leads are for the intrusion detection feature for chassis with intrusion sensor or microswitch. When you remove any chassis component, the sensor triggers and sends a high level signal to these leads to record a chassis intrusion event. The default setting is to short the CHASSIS# and the GND pin with a jumper cap to disable the function.

**Z13PG-D16 INTRUSION1**

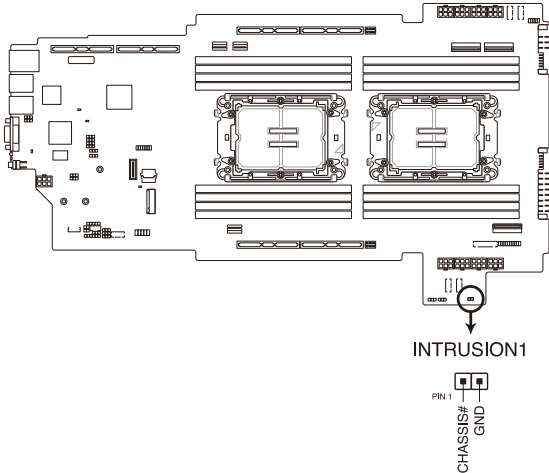

5. **Serial Port connector (10-1 pin COM1)**

This connector is for the serial COM port. Connect the serial port module cable to one of these connectors, then install the module to a slot opening at the back of the system chassis.

**Z13PG-D16 COM1**

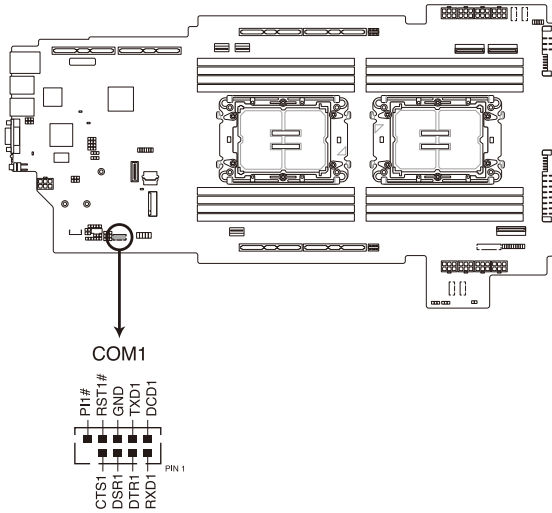

6. **TPM connector (14-1 pin TPM1)**

This connector supports a Trusted Platform Module (TPM) system, which can securely store keys, digital certificates, passwords, and data.

**Z13PG-D16 TPM1**

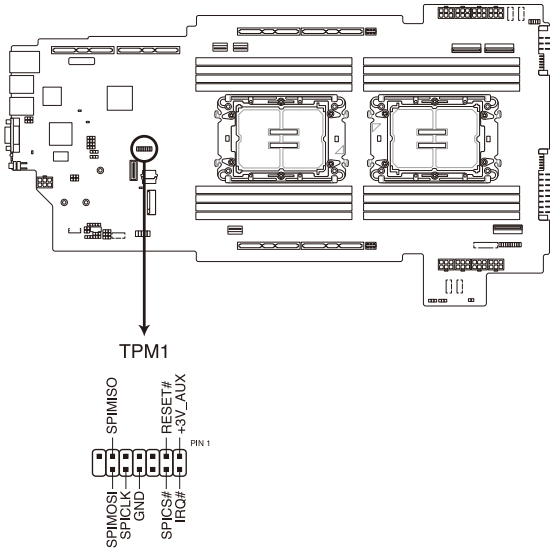

## 7. Power connector (PWR1-2)

Connects to the power sharing board and supplies power to the motherboard.



- Use of a PSU with a higher power output is recommended when configuring a system with more power-consuming devices. The system may become unstable or may not boot up if the power is inadequate.
- Ensure that your power supply unit (PSU) can provide at least the minimum power required by your system.

### Z13PG-D16 ATX power connector

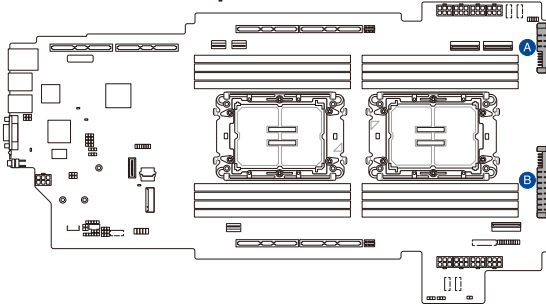

A PWR2



B PWR1





## 8. VGA Power Connectors (6-pin VGAPWR1-8)

These 12V connectors supply power to the VGA cards. The 6-pin ATX power supply plugs are designed to fit these connectors in only one orientation. Find the proper orientation and push down firmly until the connectors completely fit.

### Z13PG-D16 VGA Power connectors

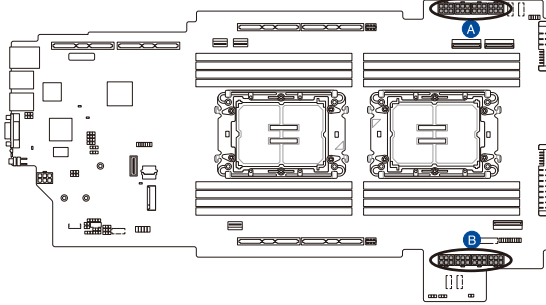

**A** VGAPWR1 VGAPWR2 VGAPWR3 VGAPWR4

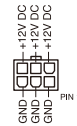
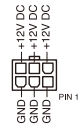
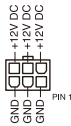
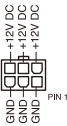

**B** VGAPWR5 VGAPWR6 VGAPWR7 VGAPWR8

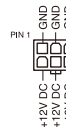
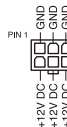
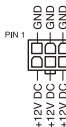
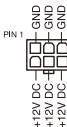

**9. BF Power connector (6-pin BFPWR1)**

This connector supplies power to the optional BlueField Ethernet DPU card. The 6-pin ATX power supply plug is designed to fit this connector in only one orientation. Find the proper orientation and push down firmly until the connector completely fits.

**Z13PG-D16 BFPWR1**

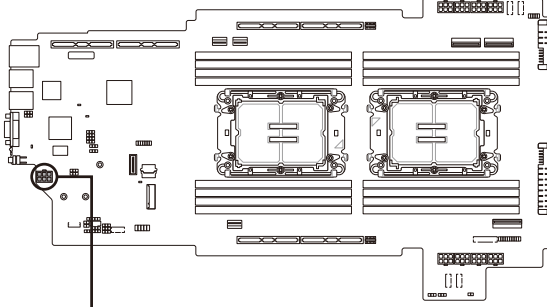

**BFPWR1**

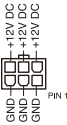

---

This power connector supplies a maximum of 150W and is only intended for use with a Bluefield Ethernet DPU card.

---

**10. BMC Debug UART connector (3-pin BMC\_DEBUGUART1)**

This connector is used for reading the BMC UART Debug log.

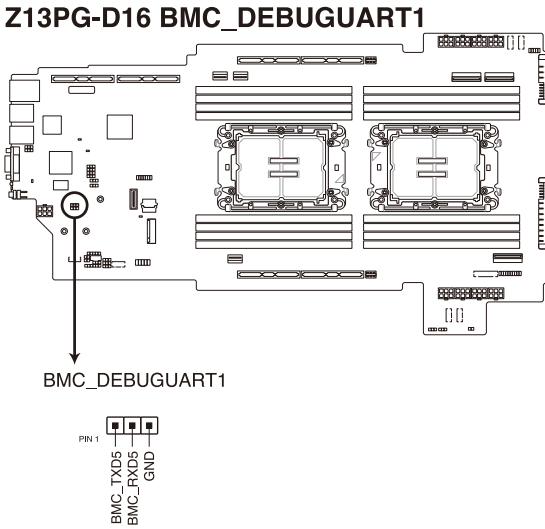

**11. Platform Firmware Resilience (PFR) Module connector (ROT\_CON1)**

This connector allows you to connect a PFR module to enable platform firmware resilience functions.

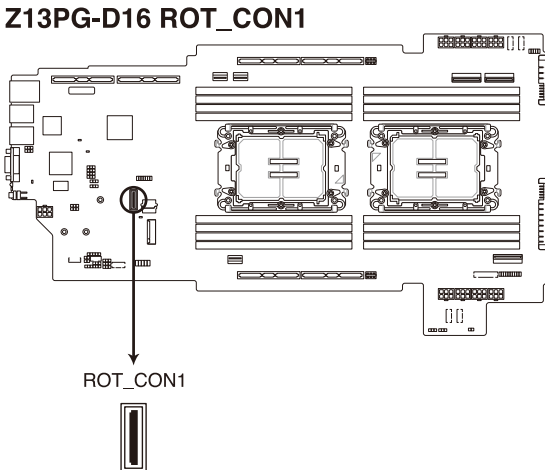

## 12. System Panel connector (20-pin SYS\_PANEL2)

This connector supports several chassis-mounted functions.

### Z13PG-D16 SYS\_PANEL1

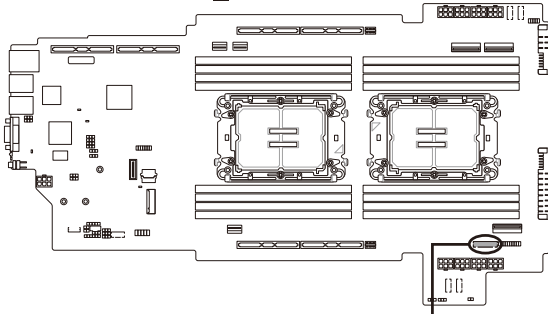

SYS\_PANEL1

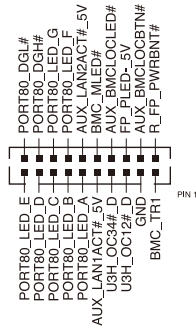

**13. Leak detection sensor connector (4-pin WL\_CON1)**

This connector allows you to connect a compatible leak detection sensor.

**Z13PG-D16 WL\_CON1**

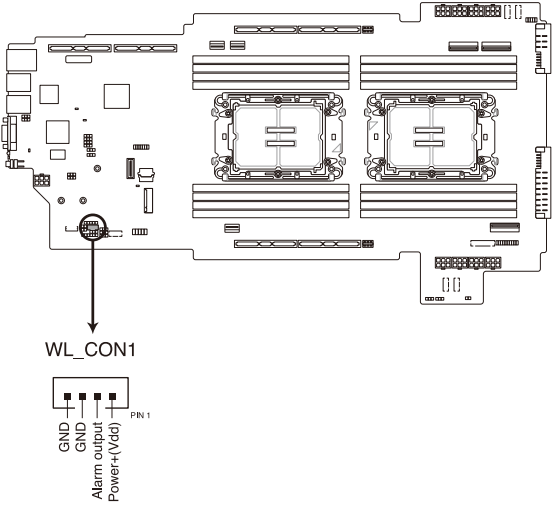

**14. VROC\_KEY connector (4-pin VROC\_KEY1)**

This connector allows you to connect a KEY module to enable CPU RAID functions with Intel® CPU RSTe.

**Z13PG-D16 VROC\_KEY1**

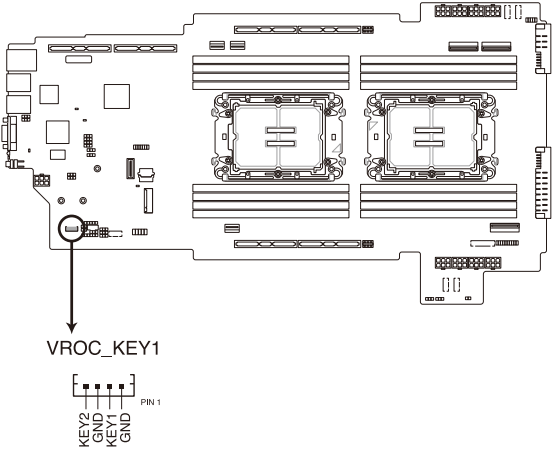

**15. M.2 (NGFF) connector (NGFF1)**

This connector allows you to install M.2 devices.

**Z13PG-D16 NGFF1**

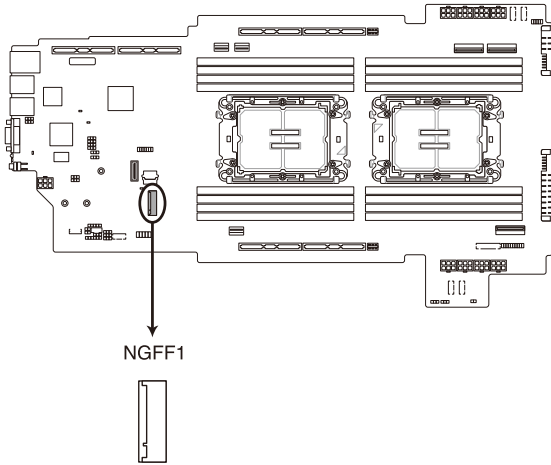

## 3.6 Onboard LEDs

### 1. Standby Power LED (SBPWR1)

The motherboard comes with a standby power LED. The green LED lights up to indicate that the system is ON, in sleep mode, or in soft-off mode. This is a reminder that you should shut down the system and unplug the power cable before removing or plugging in any motherboard component. The illustration below shows the location of the onboard LED.

#### Z13PG-D16 SBPWR1

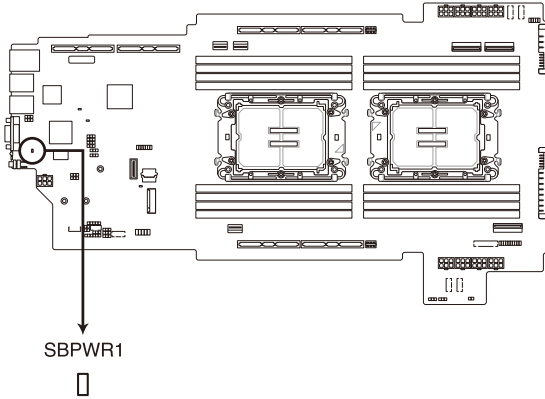

### 2. Baseboard Management Controller LED (BMCLED1)

The BMC LED lights up to indicate that the on-board BMC is functional.

#### Z13PG-D16 BMCLED1

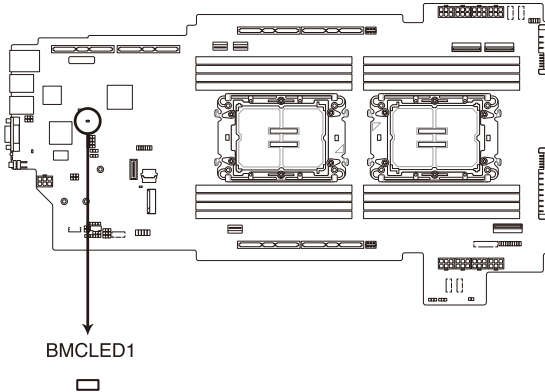

**3. Catastrophic Error LED (CATERR1)**

The catastrophic error LED indicates that the system has experienced a fatal or catastrophic error and cannot continue to operate.

**Z13PG-D16 CATERR1**

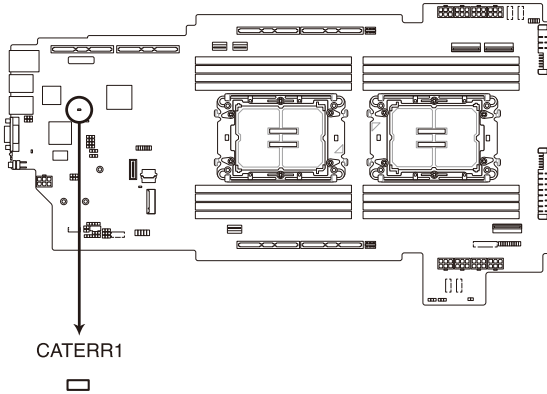

**4. Message LED (MESLED1)**

This onboard LED lights up to red when there is a temperature warning or a BMC event log is generated.

**Z13PG-D16 MESLED1**

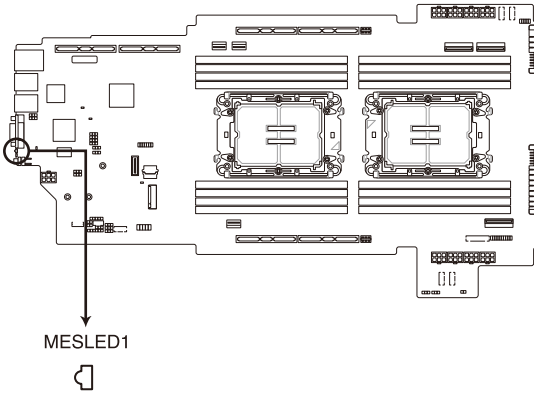



**5. Location LED (LOCLED1)**

This onboard LED lights up when the Location button on the server is pressed or when triggered by a system management software. The Location LED helps visually locate and quickly identify the server on a server rack.

**Z13PG-D16 LOCLED1**

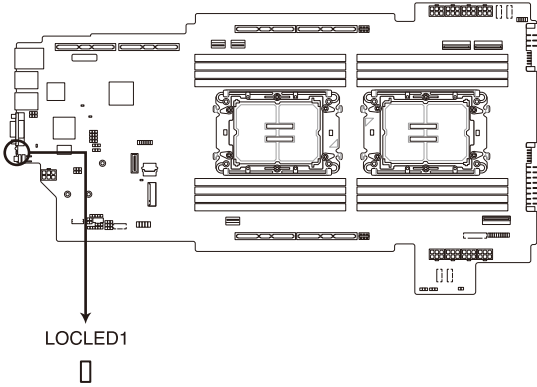



# **BIOS Setup**

# 4

This chapter tells how to change the system settings through the BIOS Setup menus. Detailed descriptions of the BIOS parameters are also provided.

## 4.1 Managing and updating your BIOS

The following utilities allow you to manage and update the motherboard Basic Input/Output System (BIOS) setup:

### 1. ASUS CrashFree BIOS 3

To recover the BIOS using a bootable USB flash disk drive if the BIOS file fails or gets corrupted.

### 2. ASUS EzFlash

Updates the BIOS using a USB flash disk.

### 4.1.1 ASUS CrashFree BIOS 3 utility

The ASUS CrashFree BIOS 3 is an auto recovery tool that allows you to restore the BIOS file if it fails or gets corrupted during the updating process. You can update a corrupted BIOS file using a USB flash drive that contains the updated BIOS file.



---

Prepare a USB flash drive containing the updated motherboard BIOS before using this utility.

---

### Recovering the BIOS from a USB flash drive

To recover the BIOS from a USB flash drive:

1. Insert the USB flash drive with the original or updated BIOS file to one USB port on the system.
2. The utility will automatically recover the BIOS. It resets the system when the BIOS recovery finished.



---

**DO NOT** shut down or reset the system while recovering the BIOS! Doing so would cause system boot failure!

---



---

The recovered BIOS may not be the latest BIOS version for this motherboard. Visit the ASUS website at [www.asus.com](http://www.asus.com) to download the latest BIOS file.

---

## 4.1.2 ASUS EZ Flash Utility

The ASUS EZ Flash Utility feature allows you to update the BIOS without having to use a DOS-based utility.



Before you start using this utility, download the latest BIOS from the ASUS website at [www.asus.com](http://www.asus.com).

To update the BIOS using EZ Flash Utility:

1. Insert the USB flash disk that contains the latest BIOS file into the USB port.
2. Enter the BIOS setup program. Go to the **Tool** menu, then select **Start ASUS EZ Flash**. Press <Enter>.

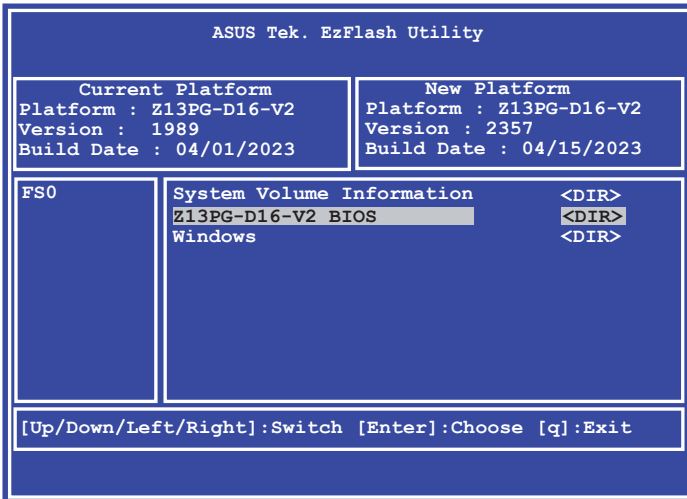

3. Press the Left/Right arrow keys to switch to the **Drive** field.
4. Press the Up/Down arrow keys to find the USB flash disk that contains the latest BIOS, then press <Enter>.
5. Press Left/Right arrow keys to switch to the **Folder Info** field.
6. Press the Up/Down arrow keys to find the BIOS file, then press <Enter> to perform the BIOS update process. Reboot the system when the update process is done.



- This function can support devices such as a USB flash disk with FAT 32/16 format and single partition only.
- DO NOT shut down or reset the system while updating the BIOS to prevent system boot failure!



Ensure to load the BIOS default settings to ensure system compatibility and stability. Press <F5> and select **Yes** to load the BIOS default settings.

## 4.2 BIOS setup program

This motherboard supports a programmable firmware chip that you can update using the provided utility described in the **Managing and updating your BIOS** section.

Use the BIOS Setup program when you are installing a motherboard, reconfiguring your system, or prompted to “Run Setup.” This section explains how to configure your system using this utility.

Even if you are not prompted to use the Setup program, you can change the configuration of your computer in the future. For example, you can enable the security password feature or change the power management settings. This requires you to reconfigure your system using the BIOS Setup program so that the computer can recognize these changes and record them in the CMOS RAM of the firmware chip.

The firmware chip on the motherboard stores the Setup utility. When you start up the computer, the system provides you with the opportunity to run this program. Press <Del> during the Power-On Self-Test (POST) to enter the Setup utility; otherwise, POST continues with its test routines.

If you wish to enter Setup after POST, restart the system by pressing <Ctrl>+<Alt>+<Delete>, or by pressing the reset button on the system chassis. You can also restart by turning the system off and then back on. Do this last option only if the first two failed.

The Setup program is designed to make it as easy to use as possible. Being a menu-driven program, it lets you scroll through the various sub-menus and make your selections from the available options using the navigation keys.



- 
- The default BIOS settings for this motherboard apply for most conditions to ensure optimum performance. If the system becomes unstable after changing any BIOS settings, load the default settings to ensure system compatibility and stability. Press <F5> and select **Yes** to load the BIOS default settings.
  - Support for BIOS functions and options may vary based on AVL testing progress. Please contact your sales representative for more information.
  - The BIOS setup screens shown in this section are for reference purposes only, and may not exactly match what you see on your screen.
  - Visit the ASUS website ([www.asus.com](http://www.asus.com)) to download the latest BIOS file for this motherboard.
-

## 4.2.1 BIOS menu screen

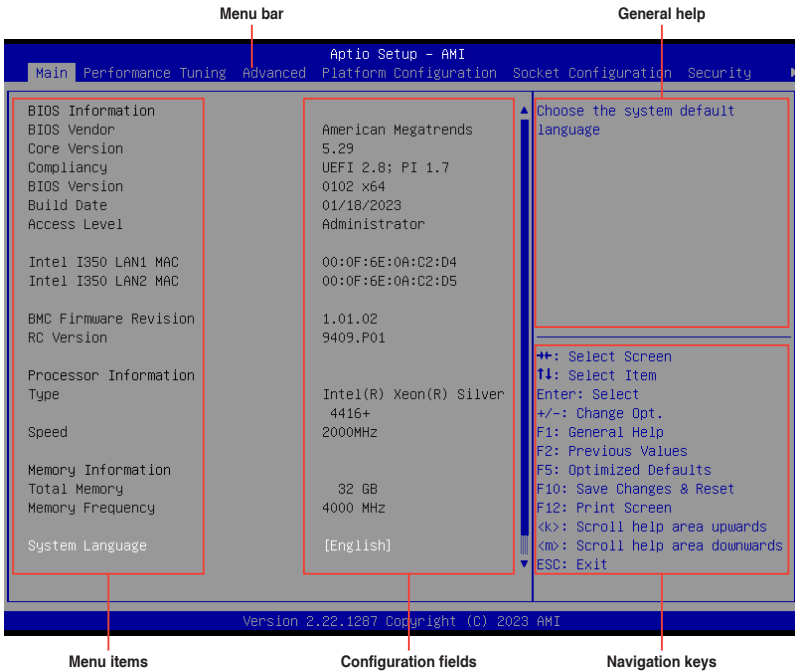

## 4.2.2 Menu bar

The menu bar on top of the screen has the following main items:

- |                    |   |
|--------------------|---|
| <b>Main</b>        | For changing the basic system configuration   |
| <b>Advanced</b>    | For changing the advanced system settings     |
| <b>Chipset</b>     | For changing the chipset settings             |
| <b>Security</b>    | For changing the security settings            |
| <b>Boot</b>        | For changing the system boot configuration    |
| <b>Tool</b>        | For configuring options for special functions |
| <b>Event Logs</b>  | For changing the event log settings           |
| <b>Server Mgmt</b> | For changing the Server Mgmt settings         |
| <b>Exit</b>        | For selecting the exit options                |

To select an item on the menu bar, press the right or left arrow key on the keyboard until the desired item is highlighted.

## Menu items

The highlighted item on the menu bar displays the specific items for that menu. For example, selecting **Main** shows the Main menu items.

The other items (such as **Advanced**) on the menu bar have their respective menu items.

## Submenu items

A solid triangle before each item on any menu screen means that the item has a submenu. To display the submenu, select the item then press <Enter>.

## Navigation keys

At the bottom right corner of a menu screen are the navigation keys for the BIOS setup program. Use the navigation keys to select items in the menu and change the settings.

## General help

At the top right corner of the menu screen is a brief description of the selected item.

## Configuration fields

These fields show the values for the menu items. If an item is user-configurable, you can change the value of the field opposite the item. You cannot select an item that is not user-configurable.

A configurable field is enclosed in brackets, and is highlighted when selected. To change the value of a field, select it and press <Enter> to display a list of options.

## Pop-up window

Select a menu item and press <Enter> to display a pop-up window with the configuration options for that item.

## Scroll bar

A scroll bar appears on the right side of a menu screen when there are items that do not fit on the screen. Press the Up/Down arrow keys or <Page Up> / <Page Down> keys to display the other items on the screen.



## 4.3 Main menu

When you enter the BIOS Setup program, the Main menu screen appears. The Main menu provides you an overview of the basic system information, and allows you to set the system date, time, and language settings.

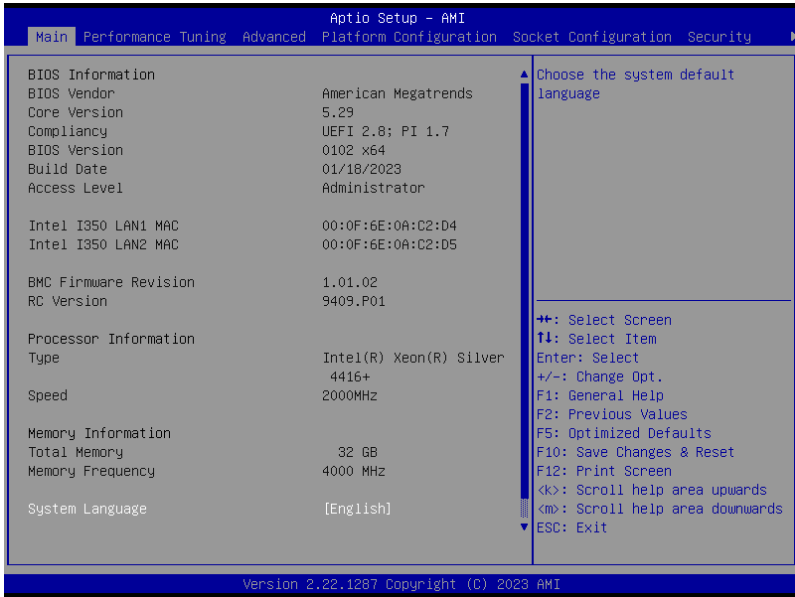

### System Language

Allows you to set the system language.

### System Date [MM/DD/YYYY]

Allows you to set the system date.

### System Time [HH:MM:SS]

Allows you to set the system time.

## 4.4 Performance Tuning menu

The Performance Tuning menu items allow you to change performance related settings for different scenarios.

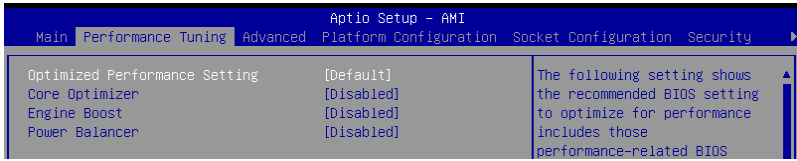

### Optimized Performance Setting [Default]

Allows you to select performance settings for different scenarios.

[Default] Default settings.

[By Benchmark] Optimize for different kinds of benchmarks. Select this option, then select a benchmark type from the >> list.

[By Workload] Optimize for different kinds of workloads. Select this option, then select a workload type from the >> list.



This function will reset some BIOS settings that you have changed back to their default values. Please check your BIOS settings again.



The following item appears only when **Power Balancer** is set to [Disabled], or if Optimized Performance Setting is set to [Default] or [By Benchmark].

### Core Optimizer [Disabled]

Allows you to keep the processor operating at the turbo highest frequency for the maximum performance.

Configuration options: [Disabled] [Auto] [Manual]



The following item appears only when you set **Core Optimizer** to [Manual].

### CPU Max frequency [XXXX]

The default value for this option will be the maximum supported frequency of the CPU installed and may vary between different CPUs.



The following item appears only when you set **Optimized Performance Setting** to [Default] or [By Benchmark].

### Engine Boost [Disabled]

Enable this item to boost the CPU's frequency. Recommended operation at an ambient temperature of 25°C or below for optimized performance.

Configuration options: [Disabled] [Normal] [Aggressive]



Operate with an ambient temperature of 25°C or lower for optimized performance.



---

The following item appears only when you set **Core Optimizer** to **[Disabled]**, or if **Optimized Performance Setting** is set to **[Default]** or **[By Benchmark]**.

---

### **Power Balancer [Disabled]**

Allows you to dynamically adjust the frequency of all CPU cores based on their current utilization, delivering better performance per watt for improved system energy efficiency.

Configuration options: [Disabled] [Enabled by BIOS] [Enabled by ACC]



---

When setting **Power Balancer** to **[Enabled by ACC]**, make sure that you have the latest ASUS Control Center software installed to support Power Balancer. Please see below for recommended software versions:

- **ACC**: 1.4.3.5 version or above.

---



---

The following item appears only when you set **Power Balancer** to **[Enabled by BIOS]** or **[Enabled by ACC]**.

---

### **Policy [Auto]**

Configuration options: [Auto] [Manual]



---

The following item appears only when you set **Policy** to **[Manual]**.

---

### **CPU Max frequency [XXXX]**

The default value for this option will be the maximum supported frequency of the CPU installed and may vary between different CPUs.

## 4.5 Advanced menu

The Advanced menu items allow you to change the settings for the CPU and other system devices.



Take caution when changing the settings of the Advanced menu items. Incorrect field values can cause the system to malfunction.

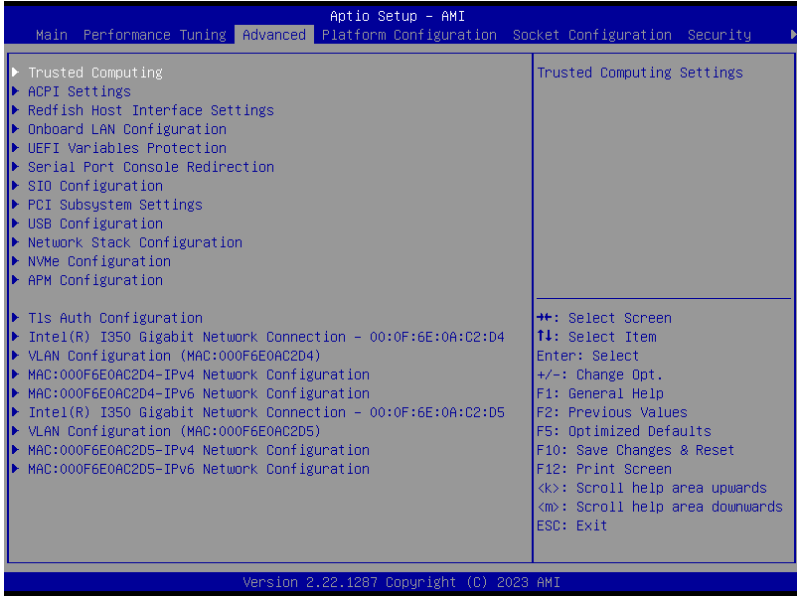

### 4.5.1 Trusted Computing

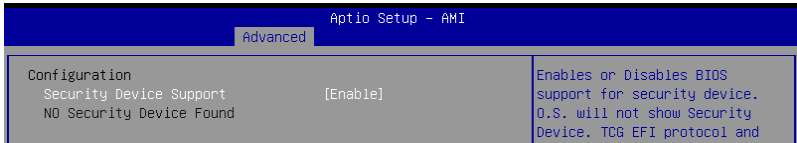

#### Configuration

#### Security Device Support [Enabled]

Configuration options: [Disabled] [Enabled]

## 4.5.2 ACPI Settings

Aptio Setup - AMI	
Advanced	
ACPI Settings	Enables or Disables BIOS ACPI Auto Configuration.
Enable ACPI Auto Configuration	[Disabled]

### Enable ACPI Auto Configuration [Disabled]

Configuration options: [Disabled] [Enabled]

## 4.5.3 Redfish Host Interface Settings

Aptio Setup - AMI	
Advanced	
Redfish Host Interface Settings	Enable/Disable AMI Redfish
Redfish	[Enabled]

### Redfish [Disabled]

Configuration options: [Disabled] [Enabled]



---

The following items appear only when **Redfish** is set to **[Enabled]**.

---

#### **Authentication mode [Basic Authentication]**

Allows you to select the authentication mode.

Configuration options: [Basic Authentication] [Session Authentication]

#### **IP address**

Allows you to enter the IP address.

#### **IP Mask address**

Allows you to enter the IP Mask address.

#### **IP Port**

Allows you to enter the IP Port.

## 4.5.4 Onboard LAN Configuration

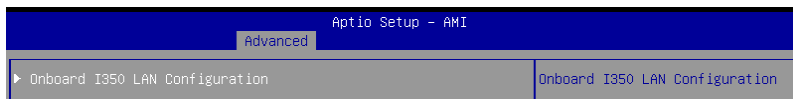

### Onboard I350 LAN Configuration

LAN1/LAN2

LAN Enable [Enabled]

Configuration options: [Disabled] [Enabled]

## 4.5.5 UEFI Variables Protection

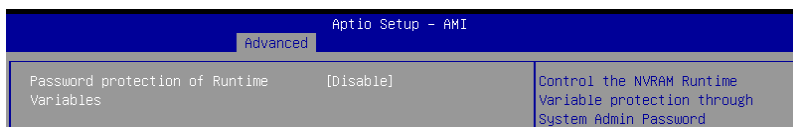

### Password protection of Runtime Variables [Disabled]

Configuration options: [Disabled] [Enabled]

## 4.5.6 Serial Port Console Redirection

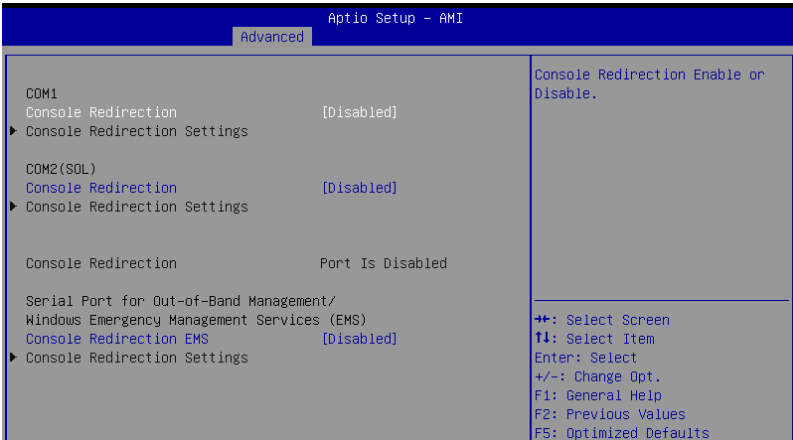

### COM1/COM2(SOL)

#### Console Redirection [Disabled]

Allows you to enable or disable the console redirection feature.

Configuration options: [Disabled] [Enabled]



The following item is available only when **Console Redirection** for **COM1** or **COM2(SOL)** is set to **[Enabled]**.

#### Console Redirection Settings

These items become configurable only when you enable the **Console Redirection** item. The settings specify how the host computer and the remote computer (which the user is using) will exchange data. Both computers should have the same or compatible settings.

#### Terminal Type [VT100Plus]

Allows you to set the terminal type.

- [VT100] ASCII char set.
- [VT100Plus] Extends VT100 to support color, function keys, etc.
- [VT-UTF8] Uses UTF8 encoding to map Unicode chars onto 1 or more bytes.
- [ANSI] Extended ASCII char set.

#### Bits per second [115200]

Selects serial port transmission speed. The speed must be matched on the other side. Long or noisy lines may require lower speeds.

Configuration options: [9600] [19200] [38400] [57600] [115200]

#### Data Bits [8]

Configuration options: [7] [8]

### **Parity [None]**

A parity bit can be sent with the data bits to detect some transmission errors. [Mark] and [Space] parity do not allow for error detection.

[None] None

[Even] Parity bit is 0 if the number of 1's in the data bits is even.

[Odd] Parity bit is 0 if number of 1's in the data bits is odd.

[Mark] Parity bit is always 1.

[Space] Parity bit is always 0.

### **Stop Bits [1]**

Stop bits indicate the end of a serial data packet. (A start bit indicates the beginning.)

The standard setting is 1 stop bit. Communication with slow devices may require more than 1 stop bit.

Configuration options: [1] [2]

### **Flow Control [None]**

Flow control can prevent data loss from buffer overflow. When sending data, if the receiving buffers are full, a "stop" signal can be sent to stop the data flow. Once the buffers are empty, a "start" signal can be sent to re-start the flow. Hardware flow control uses two wires to send start/stop signals.

Configuration options: [None] [Hardware RTS/CTS]

### **VT-UTF8 Combo Key Support [Enabled]**

This allows you to enable the VT -UTF8 Combination Key Support for ANSI/VT100 terminals.

Configuration options: [Disabled] [Enabled]

### **Recorder Mode [Disabled]**

With this mode enabled only text will be sent. This is to capture Terminal data.

Configuration options: [Disabled] [Enabled]

### **Resolution 100x31 [Enabled]**

This allows you enable or disable extended terminal resolution.

Configuration options: [Disabled] [Enabled]

### **Putty Keypad [VT100]**

This allows you to select the Function Key and Keypad on Putty.

Configuration options: [VT100] [LINUX] [XTERMR6] [SCO] [ESCN] [VT400]



## Serial Port for Out-of-Band Management/ Windows Emergency Management Services (EMS)

### Console Redirection EMS [Enabled]

Allows you to enable or disable the console redirection feature.

Configuration options: [Disabled] [Enabled]



---

The following item is available only when **Console Redirection EMS** is set to **[Enabled]**.

---

### Console Redirection Settings

#### Out-of-Band Mgmt Port [COM1]

Microsoft Windows Emergency Management Services (EMS) allow for remote management of a Windows Server OS through a serial port.

Configuration options: [COM1] [COM2(SOL)]

#### Terminal Type EMS [VT-UTF8]

VT-UTF8 is the preferred terminal type for out-of-band management. The next best choice is VT100+, and then VT100. See above, in Console Redirection Settings page for more help with Terminal Type/Emulation.

Configuration options: [VT100] [VT100+] [VT-UTF8] [ANSI]

#### Bits per second EMS [115200]

Selects serial port transmission speed. The speed must be matched on the other side. Long or noisy lines may require lower speeds.

Configuration options: [9600] [19200] [57600] [115200]

#### Flow Control EMS [None]

Flow control can prevent data loss from buffer overflow. When sending data, if the receiving buffers are full, a “stop” signal can be sent to stop the data flow. Once the buffers are empty, a “start” signal can be sent to re-start the flow. Hardware flow control uses two wires to send start/stop signals.

Configuration options: [None] [Hardware RTS/CTS] [Software Xon/Xoff]

## 4.5.7 SIO Configuration

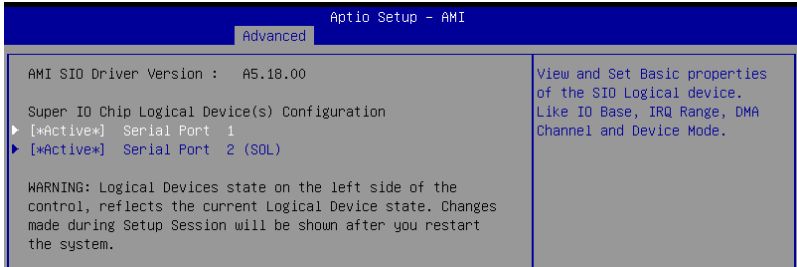

Logical Devices state on the left side of the control, reflects the current Logical Device state. Changes made during Setup Session will be shown after you restart the system.

### [\*Active\*] Serial Port 1 / [\*Active\*] Serial Port 2 (SOL)

Allows you to view and set basic properties of the SIO Logical device.

#### Use This Device [Enabled]

Allows you to enable or disable this Logical Device.

Configuration options: [Disabled] [Enabled]



The following item appears only when **Use This Device** is set to **[Enabled]**.



Disabling SIO Logical Devices may have unwanted side effects. PROCEED WITH CAUTION.

#### **Possible: [Use Automatic Settings]**

Allows the user to change the device resource settings. New settings will be reflected no this setup page after system restarts.

Configuration options: [Use Automatic Settings] [IO=3F8h; IRQ=4; DMA;]  
[IO=3F8h; IRQ=3, 4, 5, 7, 9, 10, 11, 12; DMA;] [IO=2F8h; IRQ=3, 4, 5, 7, 9, 10, 11, 12; DMA;] [IO=3E8h; IRQ=3, 4, 5, 7, 9, 10, 11, 12; DMA;] [IO=2E8h; IRQ=3, 4, 5, 7, 9, 10, 11, 12; DMA;]

## 4.5.8 PCI Subsystem Settings

Allows you to configure PCI, PCI-X, and PCI Express Settings.

Advanced		Aptio Setup - AMI
PCI Bus Driver Version	A5.01.29	Enables or Disables 64bit capable Devices to be Decoded in Above 4G Address Space (Only if System Supports 64 bit PCI Decoding).
PCI Devices Common Settings:		
Above 4G Decoding	[Enabled]	
Re-Size BAR Support	[Disabled]	
SR-IOV Support	[Enabled]	
BME DMA Mitigation	[Disabled]	

### Above 4G Decoding [Enabled]

Allows you to enable or disable 64-bit capable devices to be decoded in above 4G address space. It only works if the system supports 64-bit PCI decoding.

Configuration options: [Disabled] [Enabled]

### Re-Size BAR Support [Disabled]

If system has Resizable BAR capable PCIe Devices, this option enables or disables Resizable BAR Support. (Only if system supports 64-bit PCI Decoding).

Configuration options: [Disabled] [Enabled]

### SR-IOV Support [Enabled]

Allows you to enable or disable Single Root IO Virtualization Support if the system has SR-IOV capable PCIe devices.

Configuration options: [Disabled] [Enabled]

### BME DMA Mitigation [Disabled]

Allows you to re-enable the Bus Master Attribute disabled during PCI enumeration for PCI bridges after SMM lock.

Configuration options: [Disabled] [Enabled]

## 4.5.9 USB Configuration

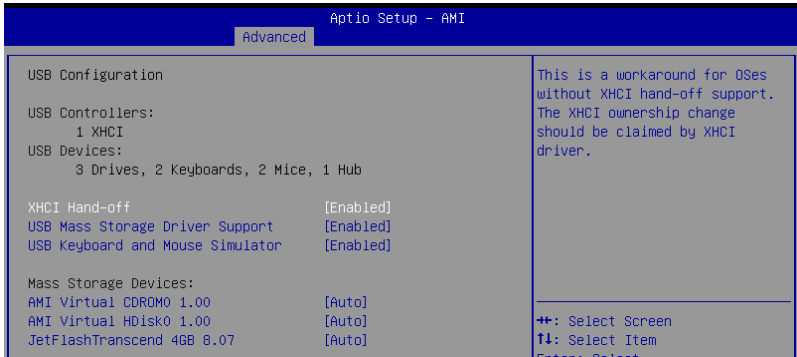

### XHCI Hand-off [Enabled]

Allows you to enable or disable workaround for OSes without XHCI hand-off support. The XHCI ownership change should be claimed by XHCI driver.

Configuration options: [Enabled] [Disabled]

### USB Mass Storage Driver Support [Enabled]

Allows you to enable or disable the USB Mass Storage driver support.

Configuration options: [Disabled] [Enabled]

### USB Keyboard and Mouse Simulator [Enabled]

Allows you to enable or disable simulation of a USB keyboard and mouse for the PS/2 module in Windows 7. Ensure that the appropriate USB drivers are installed before this option is disabled.

Configuration options: [Disabled] [Enabled]

### Mass Storage Devices

Allows you to select the mass storage device emulation type for devices connected.

Configuration options: [Auto] [Floppy] [Forced FDD] [Hard Disk] [CD-ROM]

## 4.5.10 Network Stack Configuration

Aptio Setup - AMI		
Advanced		
Network Stack	[Enabled]	Enable/Disable UEFI Network Stack
IPv4 PXE Support	[Enabled]	
IPv4 HTTP Support	[Disabled]	
IPv6 PXE Support	[Disabled]	
IPv6 HTTP Support	[Disabled]	
PXE boot wait time	0	
Media detect count	1	

### Network Stack [Enabled]

Enables or disables the UEFI network stack.

Configuration options: [Disabled] [Enabled]



The following items appear only when **Network Stack** is set to **[Enabled]**.

#### IPv4 PXE Support [Enabled]

Enables or disables the IPv4 PXE Boot Support. If disabled, IPv4 PXE boot support will not be available.

Configuration options: [Disabled] [Enabled]

#### IPv4 HTTP Support [Disabled]

Enables or disables the IPv4 HTTP Boot Support. If disabled, IPv4 HTTP boot support will not be available.

Configuration options: [Disabled] [Enabled]

#### IPv6 PXE Support [Disabled]

Enables or disables the IPv6 PXE Boot Support. If disabled, IPv6 PXE boot support will not be available.

Configuration options: [Disabled] [Enabled]

#### IPv6 HTTP Support [Disabled]

Enables or disables the IPv6 HTTP Boot Support. If disabled, IPv6 HTTP boot support will not be available.

Configuration options: [Disabled] [Enabled]

#### PXE boot wait time [0]

Set the wait time to press ESC key to abort the PXE boot. Use the <+> or <-> to adjust the value. The values range from 0 to 5.

#### Media detect count [1]

Set the number of times presence of media will be checked. Use the <+> or <-> to adjust the value. The values range from 1 to 50.

## 4.5.11 NVMe Configuration

This page will display the NVMe controller and drive information.



### Device



The devices and names shown in the NVMe configuration list depends on the connected devices. If no devices are connected, **No NVMe Device Found** will be displayed.

#### Self Test Option [Short]

This option allows you to select either Short or Extended Self Test. Short option will take couple of minutes, and the extended option will take several minutes to complete. Configuration options: [Short] [Extended]

#### Self Test Action [Controller Only Test]

This item allows you to select either to test Controller alone or Controller and NameSpace. Selecting Controller and Namespace option will take a lot longer to complete the test.

Configuration options: [Controller Only Test] [Controller and NameSpace Test]

#### Run Device Self Test

Press <Enter> to perform device self test for the corresponding Option and Action selected by the user. Pressing the <ESC> key will abort the test. The results shown below is the most recent result logged in the device.

## 4.5.12 APM Configuration

This page will allow you to configure the Advanced Power Management (APM) settings.

Aptio Setup - AMI		
Advanced		
Restore AC Power Loss	[Last State]	Select AC power state when power is re-applied after a power failure.
Power On By PCI-E	[Disabled]	
Power On By RTC	[Disabled]	

### Restore AC Power Loss [Last State]

When set to **[Power Off]**, the system goes into off state after an AC power loss. When set to **[Power On]**, the system will reboot after an AC power loss. When set to **[Last State]**, the system goes into either off or on state, whatever the system state was before the AC power loss.

Configuration options: [Power Off] [Power On] [Last State]

### Power On By PCI-E [Disabled]

[Disabled] Disables wake events from PCI-E devices.

[Enabled] Enables wake evens from PCI-E devices.

### Power On By RTC [Disabled]

[Disabled] Disables RTC to generate a wake event.

[Enabled] When set to **[Enabled]**, the items **RTC Alarm Date (Days)** and **Hour/Minute/Second** will become user-configurable with set values.

## 4.5.13 T1s Auth Configuration

Allows you to configure the Server Certificate Authority (CA).

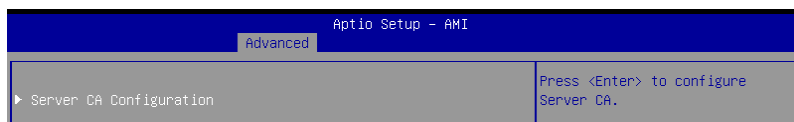

### Enroll Cert

Allows you to enroll a certificate using a certificate file or manually input a certificate GUID.

#### Enroll Cert Using File

Allows you to enroll a certificate using a certificate file. You will be prompted to select a storage device and navigate to the location of the certificate file.

#### Cert GUID

Allows you to enroll a certificate by manually inputting the certificate GUID.

#### Commit Changes and Exit

Exit Server CA configuration after saving the changes.

#### Discard Changes and Exit

Exit Server CA configuration without saving any changes.

### Delete Cert

Allows you to delete the certificate.



## 4.5.14 Third-party UEFI driver configurations

Additional configuration options for third-party UEFI drivers installed to the system will appear in the section marked in red in the screenshot below.

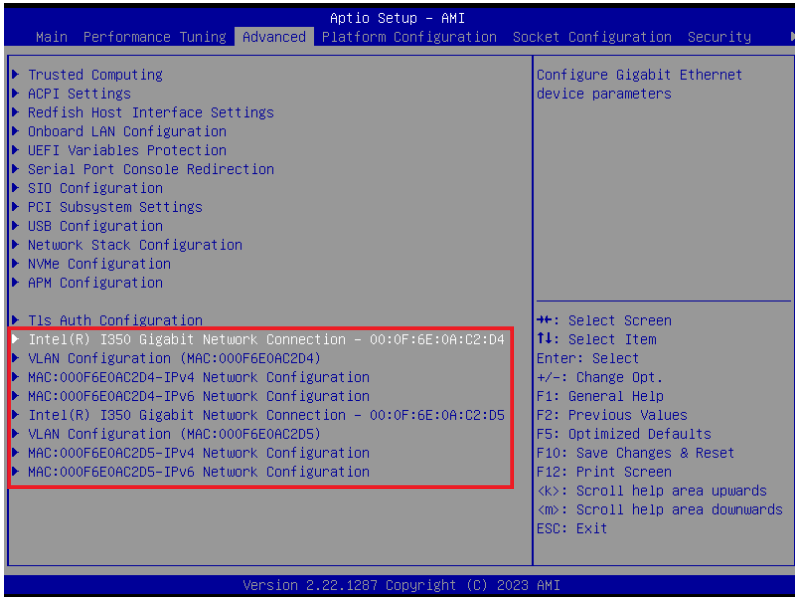

## 4.6 Platform Configuration menu

The Platform Configuration menu items allow you to change the platform settings.



Setting items in this menu to incorrect values may cause the system to malfunction!

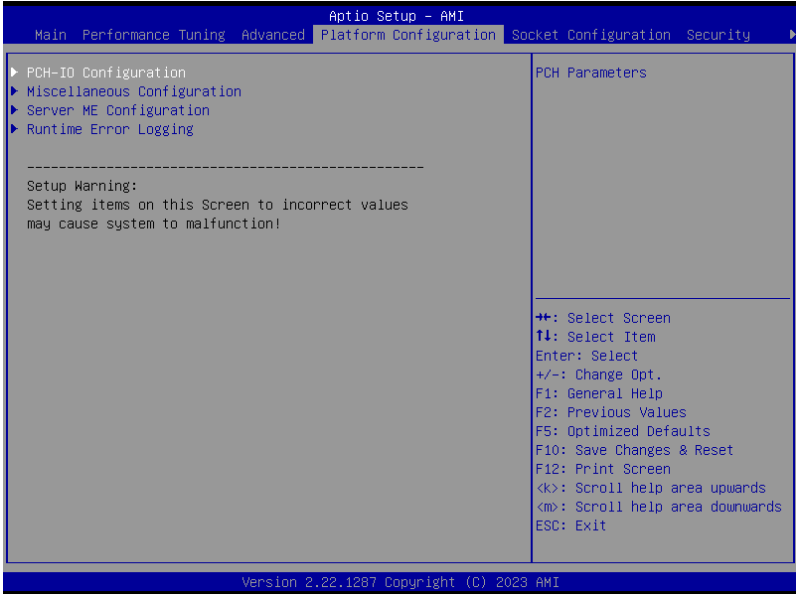

## 4.6.1 PCH-IO Configuration

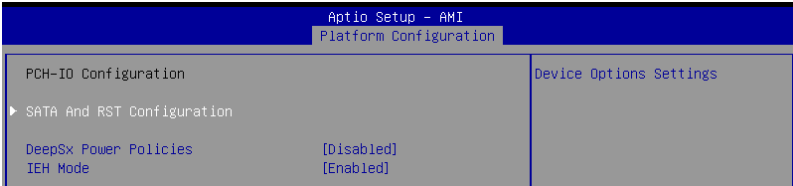

### SATA And RST Configuration

Allows you to configure SATA and RST settings.

#### DeepSx Power Policies [Disabled]

Allows you to configure the DeepSx power policy.  
Configuration options: [Disabled] [Enabled in S5]

#### IEH Mode [Enabled]

Allows you to enable or bypass Interrupt Error Handling (IEH).  
Configuration options: [Bypass Mode] [Enabled]

## 4.6.2 Miscellaneous Configuration

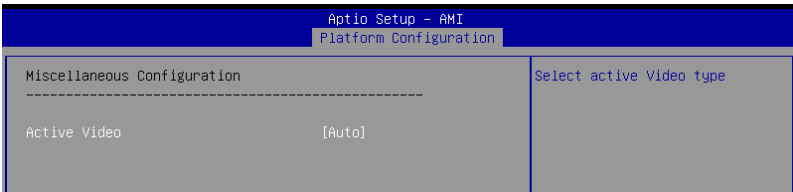

### Active Video [Auto]

Allows you to select the active video type.  
Configuration options: [Auto] [Onboard Device] [PCIe Device]

### 4.6.3 Server ME Configuration

Displays the Server ME Technology parameters on your system. Scroll using <Page Up> / <Page Down> keys to see more items.

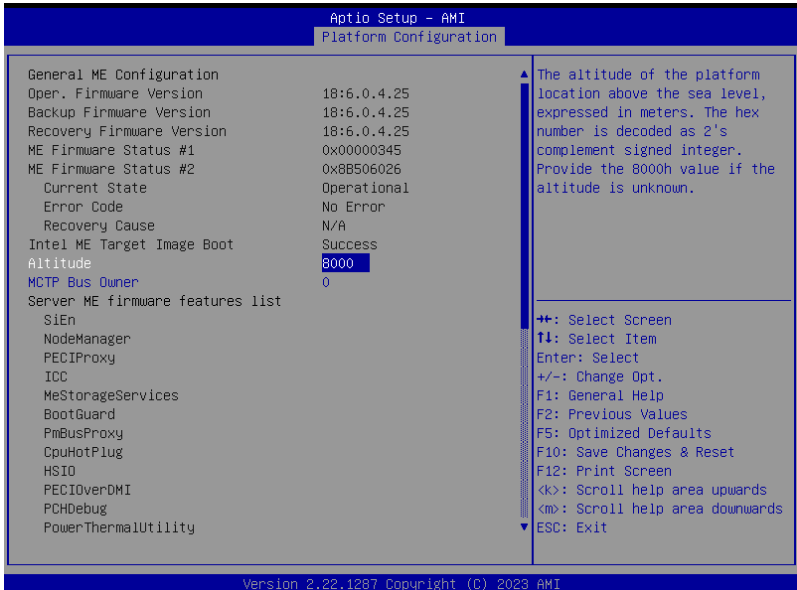

#### Altitude [8000]

Allows you to set the altitude of the platform location above the sea level, expressed in meters. The hex number is decoded as 2's complement signed integer. Provide the 8000h value if the altitude is unknown.

#### MCTP Bus Owner [0]

Allows you to enter the MCTP bus owner location on PCIe: [15:8] bus, [7:3] device, [2:0] function. If all zeros, sending bus owner will be disabled.

#### PSU #1-4

Allows you to enter the PMBus address (7-bit) that will be used to retrieve the status of the PSU. Set to 0 to disable the query..

## 4.6.4 Runtime Error Logging Support

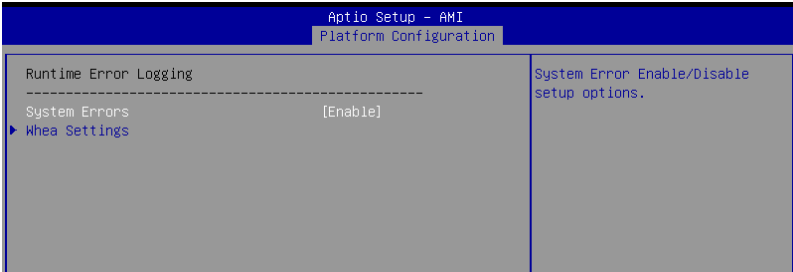

### System Errors [Enable]

Allows you to enable or disable System Errors setup options.

Configuration options: [Disable] [Enable]



---

The following item is available only when **System Errors** is set to **[Enabled]**.

---

### Whea Settings

Allows you to configure Whea settings.

# 4.7 Socket Configuration menu

The Socket Configuration menu items allow you to change the socket settings.

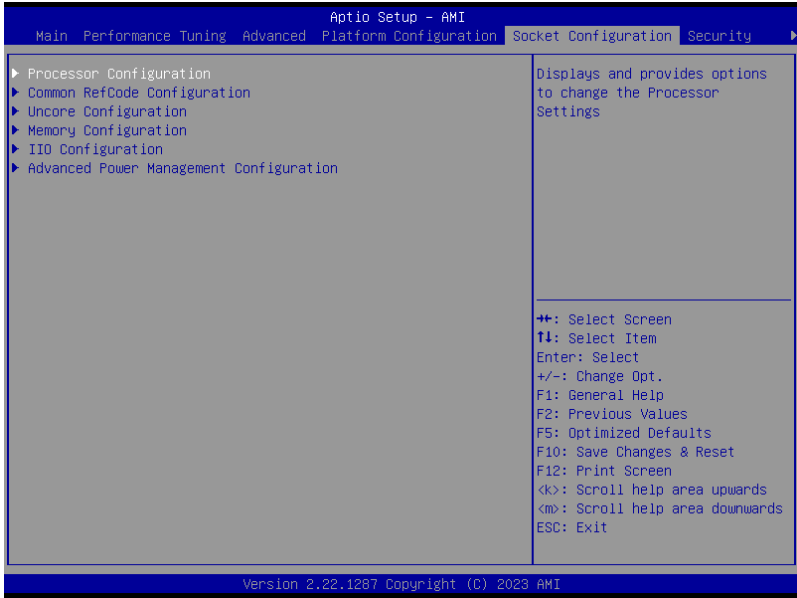

## 4.7.1 Processor Configuration

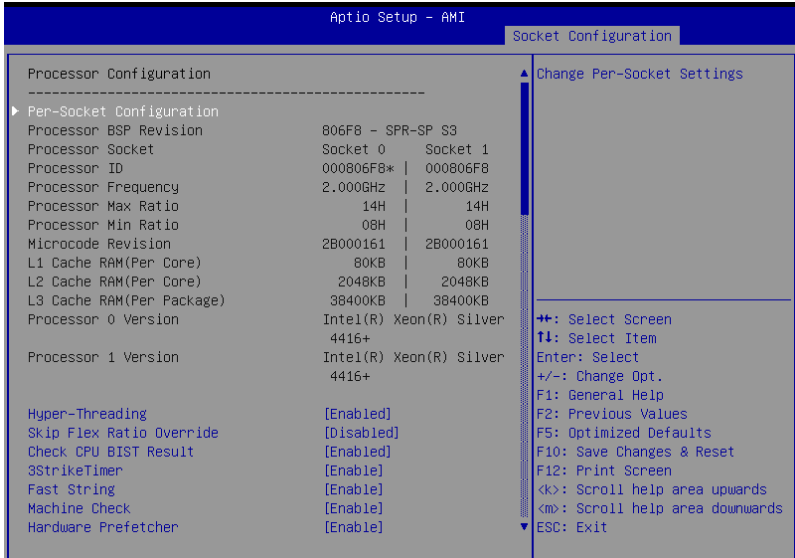

### Per-Socket Configuration

Allows you to configure per-socket settings.

### Hyper Threading [Enabled]

Allows you to enable or disable the Hyper-Threading Technology function. When disabled, only one thread per activated core is enabled. This is the software method to enable or disable Logical Processor threads.

Configuration options: [Disabled] [Enabled]

### Skip Flex Ratio Override [Disabled]

Allows you to skip flex ratio overrides to use power-on default flex ratio values. In multi-socket systems, this will allow mixed flex ratio limits.

Configuration options: [Disabled] [Enabled]

### Check CPU BIST Result [Enabled]

Allows you to check or ignore BIST results. If enabled, cores with failed BIST results will be disabled.

Configuration options: [Disabled] [Enabled]

### **3StrikeTimer [Enabled]**

Allows you to enable or disable the 3 strike counter.  
Configuration options: [Disabled] [Enabled]

### **Fast String [Enabled]**

Allows you to enable or disable fast strings for REP MOVStOS.  
Configuration options: [Disabled] [Enabled]

### **Machine Check [Enabled]**

Allows you to enable or disable the machine check.  
Configuration options: [Disabled] [Enabled]

### **Hardware Prefetcher [Enabled]**

Allows you to enable or disable the hardware prefetcher.  
Configuration options: [Disabled] [Enabled]

### **L2 RFO Prefetch Disable [Disabled]**

Allows you to turn enable or disable L2 RFO prefetcher.  
Configuration options: [Disabled] [Enabled]

### **Adjacent Cache Prefetch [Enabled]**

Allows you to enable or disable prefetching of adjacent cache lines.  
Configuration options: [Disabled] [Enabled]

### **DCU Streamer Prefetcher [Enabled]**

Allows you to enable or disable the L1 data cache prefetcher (MSR 1A4h [2]).  
Configuration options: [Disabled] [Enabled]

### **DCU IP Prefetcher [Enabled]**

Allows you to enable or disable the L1 data cache prefetcher (MSR 1A4h [3]).  
Configuration options: [Disabled] [Enabled]

### **LLC Prefetch [Disabled]**

Allows you to enable or disable LLC Prefetch on all threads.  
Configuration options: [Disabled] [Enabled]

### **Homeless Prefetch [Auto]**

Allows you to enable or disable Homeless Prefetch on all threads.  
Configuration options: [Disabled] [Enabled] [Auto]

### **FB Thread Slicing [Disabled]**

Allows you to enable or disable fill buffer thread slicing per thread.  
Configuration options: [Disabled] [Enabled]

### **AMP Prefetch [Disabled]**

Allows you to enable or disable MLC AMP Prefetch.  
Configuration options: [Disabled] [Enabled]

### **Bsp Selection [Auto]**

Choose the method for BSP selection. Auto maps to hardware default BSP.  
Configuration options: [Socket 0-1] [Auto]



## Extended APIC [Enabled]

Allows you to enable or disable the extended APIC support.

Configuration options: [Disabled] [Enabled]



---

Enabling Extended APIC will automatically enable VT-d and Interrupt Remapping.

---

## APIC Physical Mode [Disabled]

Allows you to enable or disable the APIC physical destination mode.

Configuration options: [Disabled] [Enabled]

## PECI Trust Mode [Use per-PECI agent trust mode]

Allows you to select the PEFI trust mode

Configuration options: [All PEFI Agents untrusted] [All PEFI Agents trusted] [Use per-PECI agent trust mode]



---

The following items are available only when **PECI Trust Mode** is set to **[Use per-PECI agent trust mode]**.

---

### Legacy Agent [Enabled]

Allows you to enable or disable legacy agent trust.

Configuration options: [Disabled] [Enabled]

### SMBus Agent [Disabled]

Allows you to enable or disable SMBus agent trust.

Configuration options: [Disabled] [Enabled]

### IE Agent [Enabled]

Allows you to enable or disable IE agent trust.

Configuration options: [Disabled] [Enabled]

### Generic Agent [Disabled]

Allows you to enable or disable generic agent trust.

Configuration options: [Disabled] [Enabled]

### eSPI Agent [Disabled]

Allows you to enable or disable eSPI agent trust.

Configuration options: [Disabled] [Enabled]

### DfxRedManu Agent [Disabled]

Allows you to enable or disable DfxRedManu agent trust.

Configuration options: [Disabled] [Enabled]

### DfxOrange Agent [Disabled]

Allows you to enable or disable DfxOrange agent trust.

Configuration options: [Disabled] [Enabled]

### **DBP-F [Disabled]**

Allows you to enable or disable DBP-F.  
Configuration options: [Disabled] [Enabled]

### **IIO LLC Ways [14:0] (Hex) [0]**

Allows you to set the bitmask for IIO LLC Ways. All bits set in the mask must be contiguous.

### **SMM Blocked and Delayed [Disabled]**

Allows you to enable or disable SMM Blocked and Delayed.  
Configuration options: [Disabled] [Enabled]

### **eSMM Save State [Disabled]**

Allows you to enable or disable the eSMM save state feature.  
Configuration options: [Disabled] [Enabled]

### **Smbus Error Recovery [Enabled]**

Allows you to enable or disable Smbus Error Recovery.  
Configuration options: [Disabled] [Enabled]

### **Enable Intel(R) TXT [Disabled]**

Allows you to enable or disable Intel® TXT.  
Configuration options: [Disabled] [Enabled]



---

The following items are available only when **Intel(R) TXT** is set to **[Disabled]**.

---

#### **VMX [Enabled]**

Allows you to enable or disable Vanderpool Technology.  
Configuration options: [Disabled] [Enabled]

#### **Enable SMX [Disabled]**

Allows you to enable or disable Safer Mode Extensions.  
Configuration options: [Disabled] [Enabled]

#### **Lock Chipset [Enabled]**

Allows you to lock or unlock the chipset.  
Configuration options: [Disabled] [Enabled]

### **MSR Lock Control [Enabled]**

Allows you to lock or unlock MSR 3Ah and CSR 80h.  
Configuration options: [Disabled] [Enabled]

### **PPIN Control [Unlock/Enabled]**

Allows you to enable or disable PPIN Control.  
Configuration options: [Lock/Disabled] [Unlock/Enabled]

## **AES-NI [Enable]**

Allows you to enable or disable AES-NI support.

Configuration options: [Disable] [Enable]

## **TME, TME-MT, TDX**

### **Memory Encryption (TME) [Disabled]**

Allows you to enable or disable memory encryption (TME).

Configuration options: [Disabled] [Enabled]



---

The following item appears only when **Memory Encryption (TME)** is set to **[Enabled]**.

---

#### **Total Memory Encryption (TME) Bypass [Disabled]**

Allows you to enable or disable Total Memory Encryption (TME).

Configuration options: [Disabled] [Enabled]

## **Software Guard Extension (SGX)**

### **SGX Factory Reset [Disabled]**

Allows you to enable or disable SGX factory reset, which deletes all registration data, on the subsequent boot.

Configuration options: [Disabled] [Enabled]



---

When enabled, the system will force Initial Platform Establishment flow.

---

### **SW Guard Extensions (SGX) [Disabled]**

Allows you to enable or disable Software Guard Extensions (SGX).

Configuration options: [Disabled] [Enabled]

### **SGX Package Info In-Band Access [Disabled]**

Allows you to enable or disable Software Guard Extensions (SGX) package info in-band access.

Configuration options: [Disabled] [Enabled]



---

The following items appear only when **SW Guard Extensions (SGX)** is set to **[Enabled]**.

---

#### **SGX PRM Size [256M]**

Allows you to select the SGX PRM size, which may not be equal to the total PRM size.

Configuration options: [256M] [512M] [1G] [2G] [4G] [8G] [16G]

#### **SGX QoS [Enabled]**

Allows you to enable or disable SGX Quality of Service.

Configuration options: [Disabled] [Enabled]

#### **Select Owner EPOCH input type [Manual User Defined Owner EPOCHs]**

Allows you to select the owner EPOCH input type. Each EPOCH is 64-bit.

Configuration options: [Change to New Random Owner EPOCHs] [Manual User Defined Owner EPOCHs]

### **Software Guard Extensions Epoch 0 [67]**

Allows you to set Software Guard Extensions Epoch 0.

### **Software Guard Extensions Epoch 1 [4388E8D3C9E73ADC]**

Allows you to set Software Guard Extensions Epoch 1.

### **SGXLEPUBKEYHASHx Write Enable [Enabled]**

Allows you to enable or disable writing to SGXLEPUBKEYHASH [3..0] from PS/SW.  
Configuration options: [Disabled] [Enabled]



---

The following items appear only when **SGXLEPUBKEYHASHx Write Enable** is set to **[Enabled]**.

---

#### ***SGXLEPUBKEYHASH0 [0]***

Allows you to input SGX launch enclave public key hash byte 7-0.

#### ***SGXLEPUBKEYHASH1 [0]***

Allows you to input SGX launch enclave public key hash byte 15-8.

#### ***SGXLEPUBKEYHASH2 [0]***

Allows you to input SGX launch enclave public key hash byte 23-16.

#### ***SGXLEPUBKEYHASH3 [0]***

Allows you to input SGX launch enclave public key hash byte 31-24.

#### ***SGX Auto MP Registration [Disabled]***

Allows you to enable or disable automatic registration in OS MPA agent.  
Configuration options: [Disabled] [Enabled]

### **In Field Test (IFT)**

Press <Enter> to bring up the In Field Test menu.

#### **Enable SAF [Disabled]**

Allows you to enable or disable Scan At Field (SAF)

Configuration options: [Disabled] [Enabled]



---

The following item appears only when **Enable SAF** is set to **[Enabled]**.

---

#### ***SAF size [128M]***

Allows you to set the SAF size region inside of PRM.

## PSMI Configuration

Press <Enter> to bring up the PSMI Configuration menu.

### **Global PSMI Enable [Enable]**

Allows you to enable or disable Scan At Field (SAF)  
Configuration options: [Disabled] [Enabled] [Force setup]



---

The following items appear only when **Global PSMI Enable** is set to **[Enable]** or **[Force setup]**.

---

### ***Socket 0/1 Configuration***

Press <Enter> to bring up the Socket 0/1 Configuration menu.

### ***PSMI Enable***

Allows you to enable or disable PSMI Enable.  
Configuration options: [Disabled] [Enabled]

## Processor CFR Configuration

Press <Enter> to bring up the Processor CFR Configuration menu that displays and provides options to change the processor CFR settings.

### **Provision S3M CFR [Enable]**

Allows you to enable or disable provision S3M CFR.  
Configuration options: [Disabled] [Enabled]



---

The following item appears only when **Provision S3M CFR** is set to **[Enable]**.

---

### ***Manual Commit S3M FW CFR [Disable]***

Allows you to enable or disable manual commit S3M FW CFR.  
Configuration options: [Disabled] [Enabled]

### **Provision PUCode CFR [Enable]**

Allows you to enable or disable provision PUCode CFR.  
Configuration options: [Disabled] [Enabled]



---

The following item appears only when **Provision PUCode CFR** is set to **[Enable]**.

---

### ***Manual Commit PUCode CFR [Disable]***

Allows you to enable or disable manual commit PUCode CFR.  
Configuration options: [Disabled] [Enabled]

### **Socket0/1/2/3 CFR Revision Info**

These items display the CFR revision info for each socket.

## 4.7.2 Common RefCode Configuration

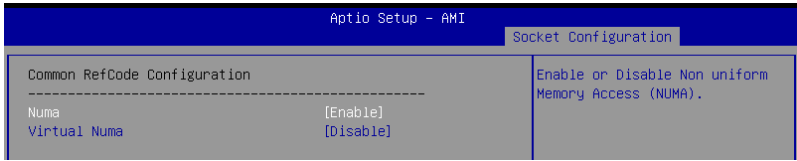

### Numa [Enabled]

Allows you to enable or disable non-uniform memory access (NUMA).

Configuration options: [Disabled] [Enabled]

### Virtual Numa [Disabled]

Allows you to enable or disable virtual non-uniform memory access (NUMA).

Configuration options: [Disabled] [Enabled]

## 4.7.3 Uncore Configuration



### Uncore General Configuration

Allows you to configure Uncore General settings.

### Uncore Per Socket Configuration

Allows you to configure Uncore Per Socket settings.

## 4.7.4 Memory Configuration

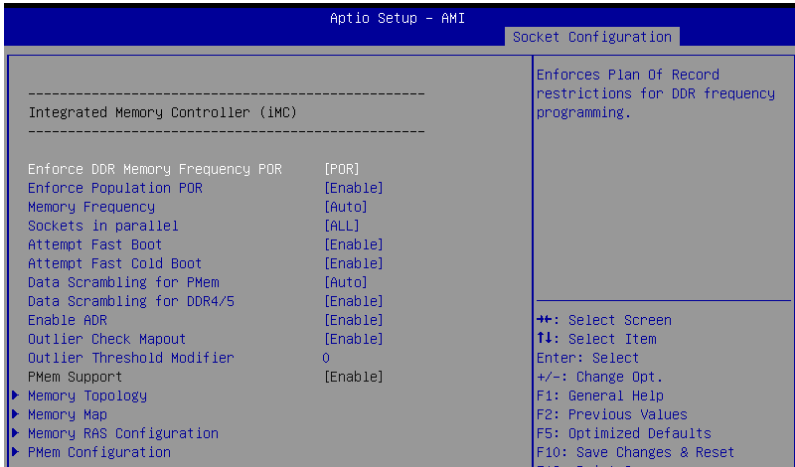

### Enforce DDR Memory Frequency POR [POR]

Allows you to enforce POR restrictions for DDR frequency and voltage programming. If this item is disabled, system memory can be run at frequencies higher than the memory supports, specified in the Memory Frequency field (limited by processor support).

Configuration options: [POR] [Disabled]

### Enforce Population POR [Enabled]

Allows you to enforce POR restrictions for memory population.

Configuration options: [Disabled] [Enabled]

### Memory Frequency [Auto]

Allows you to set the maximum memory frequency in MHz. If Enforce POR is disabled, system memory can be run at frequencies higher than the memory supports (limited by processor support).

Configuration options: [Auto] [3200] [3600] [4000] [4400] [4800]

### Sockets in Parallel [All]

Allows you to set the number of sockets operating in parallel.

Configuration options: [All] [1] [2] [4]

### Attempt Fast Boot [Enabled]

Allows you to enable or disable fast boot. Portions of memory reference code will be skipped when possible to increase boot speed on warm boots.

Configuration options: [Disabled] [Enabled]

### Attempt Fast Cold Boot [Enabled]

Allows you to enable or disable fast cold boot. Portions of memory reference code will be skipped when possible to increase boot speed on cold boots.

Configuration options: [Disabled] [Enabled]

### **Data Scrambling for PMem [Auto]**

Allows you to enable or disable data scrambling for PMem. If set to Auto, data scrambling will be enabled or disabled depending on stepping.

Configuration options: [Disabled] [Enabled] [Auto]

### **Data Scrambling for DDR4/5 [Enabled]**

Allows you to enable or disable data scrambling for DDR4/5.

Configuration options: [Disabled] [Enabled]

### **Enable ADR [Enabled]**

Allows you to enable or disable ADR. Automatically enabled if fADR is enabled.

Configuration options: [Disabled] [Enabled]

### **Outlier Check Mapout [Enabled]**

Configuration options: [Disabled] [Enabled]

### **Outlier Threshold Modifier [0]**

Allows you to modify the base outlier threshold.

### **Memory Topology**

Displays memory topology with DIMM population information.

### **Memory Map**

Allows you to configure memory mapping settings.

### **Memory RAS Configuration**

Allows you to configure memory RAS settings.

### **PMem Configuration**

Allows you to configure PMem settings.



## 4.7.5 IIO Configuration



### Intel(R) VT for Directed I/O (VT-d)

#### Intel(R) VT for Directed I/O [Enabled]

Allows you to enable or disable the Intel Virtualization Technology for Directed I/O (VT-d) by reporting the I/O device assignment to VMM through DMAR ACPI Tables. Configuration options: [Disabled] [Enabled]



The following items are available only when **Intel(R) VT for Directed I/O** is set to **[Enabled]**.

#### ***DMA Control Opt-in Flag [Disabled]***

Configuration options: [Disabled] [Enabled]

#### ***Pre-boot DMA Protection [Disabled]***

Configuration options: [Disabled] [Enabled]

## 4.7.6 Advanced Power Management Configuration



### CPU P State Control

Allows you to configure CPU P State Control settings.

### Hardware PM State Control

Allows you to configure Hardware PM State Control settings.

### Frequency Prioritization

Allows you to configure Frequency Prioritization settings.

### CPU C State Control

Allows you to configure CPU C State Control settings.

### Package C State Control

Allows you to configure Package C State Control settings.

## 4.8 Security menu

This menu allows a new password to be created or a current password to be changed. The menu also enables or disables the Secure Boot state and lets the user configure the System Mode state.

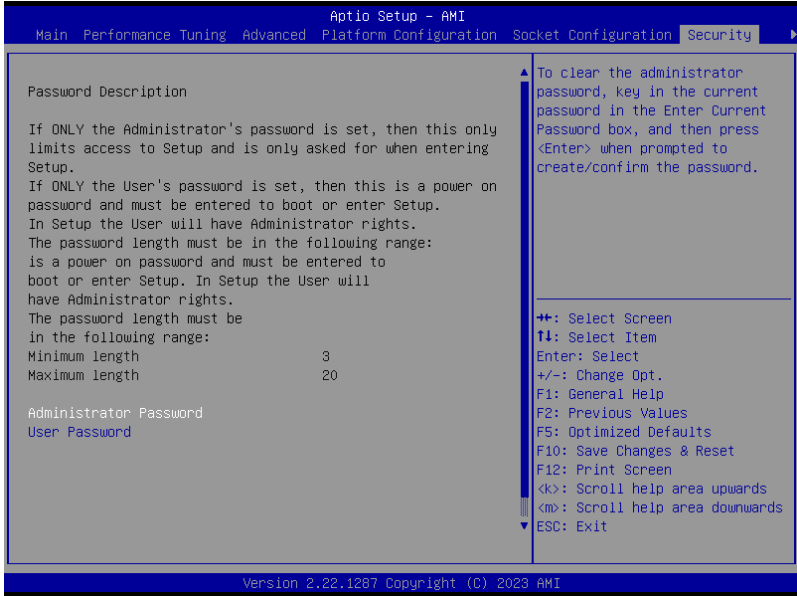

### Administrator Password

To set an administrator password:

1. Select the Administrator Password item and press <Enter>.
2. From the Create New Password box, enter a password, then press <Enter>.
3. Confirm the password when prompted.

To change an administrator password:

1. Select the Administrator Password item and press <Enter>.
2. From the Enter Current Password box, enter the current password, then press <Enter>.
3. From the Create New Password box, enter a new password, then press <Enter>.
4. Confirm the password when prompted.



To clear the administrator password, follow the same steps as in changing an administrator password, but press <Enter> when prompted to create/confirm the password.

## User Password

To set a user password:

1. Select the User Password item and press <Enter>.
2. From the Create New Password box, enter a password, then press <Enter>.
3. Confirm the password when prompted.

To change a user password:

1. Select the User Password item and press <Enter>.
2. From the Enter Current Password box, enter the current password, then press <Enter>.
3. From the Create New Password box, enter a new password, then press <Enter>.
4. Confirm the password when prompted.

To clear a user password:

1. Select the Clear User Password item and press <Enter>.
2. Select **Yes** from the Warning message window, then press <Enter>.

## Secure Boot

### Secure Boot [Disabled]

Secure Boot can be enabled if the system is running in User mode with enrolled platform Key (EPK) or if the CSM function is disabled.  
Configuration options: [Disabled] [Enabled]

### Secure Boot Mode [Custom]

Allows you to set the Secure Boot selector.  
Configuration options: [Standard] [Custom]

### Install Default Secure Boot Keys

Allows you to load the default secure boot keys.

### Clear Secure Boot Keys

Allows you to delete all previously applied secure boot keys.

### Key Management

Allows you to configure Key Management options.

## 4.9 Boot menu

The Boot menu items allow you to change the system boot options.

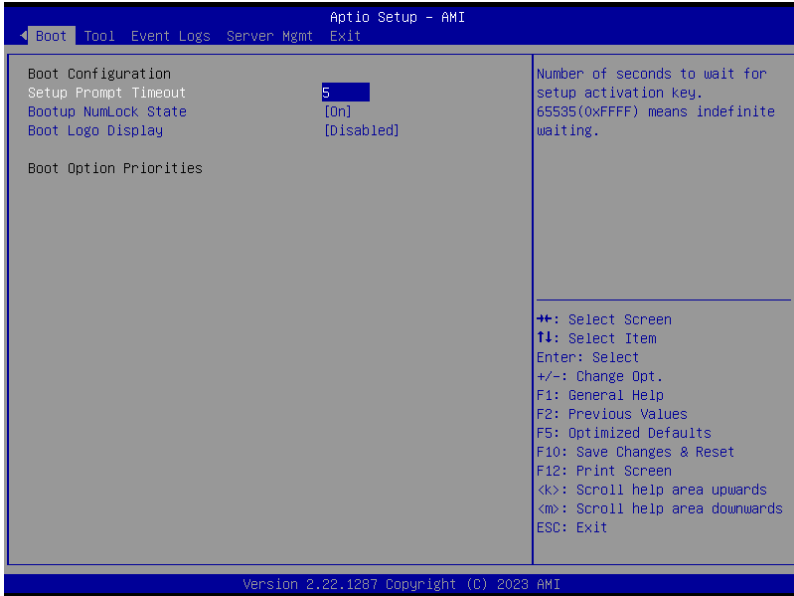

### Setup Prompt Timeout [5]

Allows you to set the number of seconds that the firmware waits before initiating the original default boot selection. 65535(0xFFFF) means indefinite waiting. Use the <+> or <-> to adjust the value.

### Bootup NumLock State [On]

Allows you to select the power-on state for the NumLock.

Configuration options: [Off] [On]

### Boot Logo Display [Disabled]

[Disabled] Hide the logo during POST.

[Enabled] Display the logo during POST.

### Boot Option Priorities

These items specify the boot device priority sequence from the available devices. The number of device items that appears on the screen depends on the number of devices installed in the system.



- To select the boot device during system startup, press <F11> when logo appears.
- To access Windows OS in Safe Mode, please press <F8> after POST.

## 4.10 Tool menu

The Tool menu items allow you to configure options for special functions. Select an item, then press <Enter> to display the submenu.

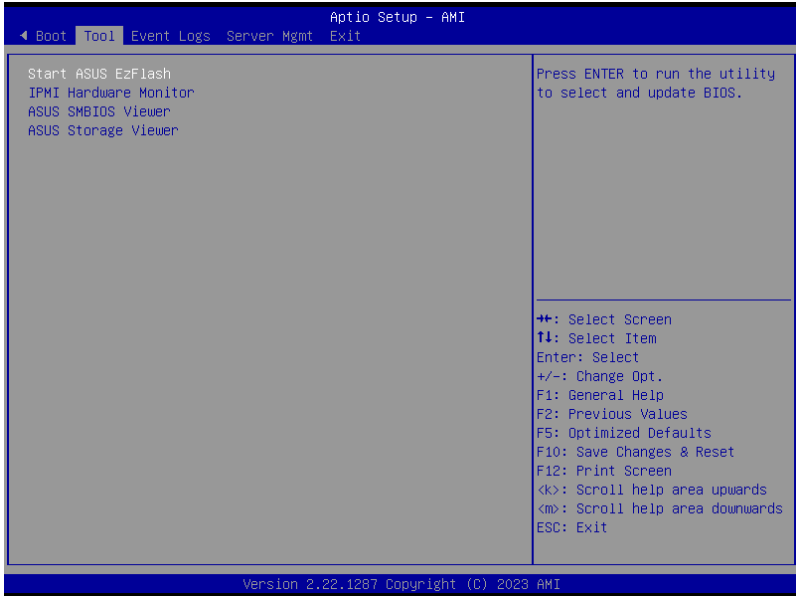

### Start ASUS EzFlash

Allows you to start the ASUS EzFlash BIOS ROM Utility. Refer to the **ASUS EzFlash Utility** section for details.

### IPMI Hardware Monitor

Allows you to start the IPMI hardware monitor.

### ASUS SMBIOS Viewer

Allows you to start the ASUS SMBIOS Viewer.

### ASUS Storage Viewer

Allows you to start the ASUS Storage Viewer.

## 4.11 Event Logs menu

The Event Logs menu items allow you to change the event log settings and view the system event logs.

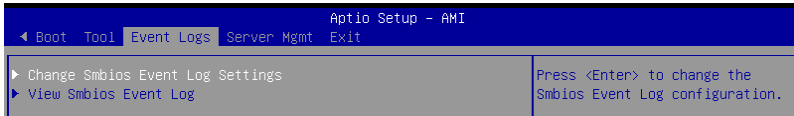

### 4.11.1 Change Smbios Event Log Settings

Press <Enter> to change the Smbios Event Log configuration.



---

All values changed here do not take effect until computer is restarted.

---

#### Smbios Event Log [Enabled]

Change this to enable or disable all features of Smbios Event Logging during boot.  
Configuration options: [Disabled] [Enabled]



---

The following item appears only when **Smbios Event Log** is set to **[Enabled]**.

---

#### Erase Event Log [No]

Choose options for erasing Smbios Event Log. Erasing is done prior to any logging activation during reset.

Configuration options: [No] [Yes, Next reset] [Yes, Every reset]

#### When Log is Full [Do Nothing]

Choose options for reactions to a full Smbios Event Log.

Configuration options: [Do Nothing] [Erase Immediately]

#### Log EFI Status Code [Enabled]

This option allows you to enable or disable logging of the EFI Status Codes.

Configuration options: [Disabled] [Enabled]



---

The following item appears only when **Log EFI Status Code** is set to **[Enabled]**.

---

#### **Convert EFI Status Codes to Standard Smbios Type [Disabled]**

This option allows you to enable or disable converting of EFI Status Codes to Standard Smbios Type (Not all may be translated).

Configuration options: [Disabled] [Enabled]

### 4.11.2 View Smbios Event Log

Press <Enter> to view all Smbios event logs.

## 4.12 Server Mgmt menu

The Server Management menu displays the server management status and allows you to change the settings.



### OS Watchdog Timer [Disabled]

This item allows you to start a BIOS timer which can only be shut off by Management Software after the OS loads.

Configuration options: [Enabled] [Disabled]



The following items appear only when **OS Watchdog Timer** is set to **[Enabled]**.

#### OS Wtd Timer Timeout [10]

Enter the value between 1 to 30 minutes to configure the length for the OS Boot Watchdog Timer.

#### OS Wtd Timer Policy [Reset]

This item allows you to configure the how the system should respond if the OS Boot Watch Timer expires.

Configuration options: [Do Nothing] [Reset] [Power Down] [Power Cycle]

### Serial Mux [Disabled]

Configuration options: [Enabled] [Disabled]

## 4.12.1 System Event Log

Allows you to change the SEL event log configuration.

### SEL Components [Enabled]

Allows you to enable or disable event logging for error/progress codes during boot.

Configuration options: [Disabled] [Enabled]



---

The following item appears only when **SEL Components** is set to **[Enabled]**.

---

### Erase SEL [No]

Allows you to choose options for erasing SEL.

Configuration options: [No] [Yes, On next reset] [Yes, On every reset]

## 4.12.2 View FRU Information

Allows you to view FRU information.

## 4.12.3 BMC network configuration

The sub-items in this configuration allow you to configure the BMC network parameters.

### DM\_LAN/Shared LAN

#### Configuration Address source [Unspecified]

Configuration options: [Unspecified] [Static] [DynamicBmcDhcp]

## 4.12.4 View System Event Log

This item allows you to view the system event log records.



## 4.13 Save & Exit menu

The Save & Exit menu items allow you to save or discard your changes to the BIOS items.

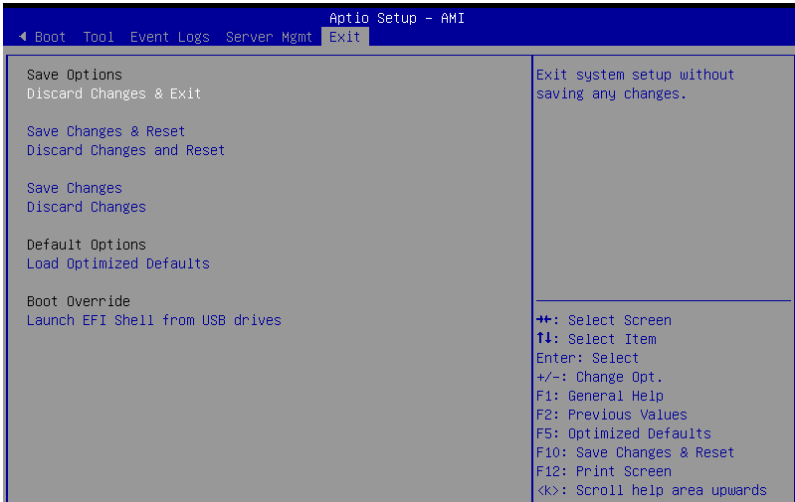

Pressing <Esc> does not immediately exit this menu. Select one of the options from this menu or <F10> from the legend bar to exit.

### Discard Changes and Exit

Exit system setup without saving any changes.

### Save Changes and Reset

Reset system after saving the changes.

### Discard Changes and Reset

Reset system setup without saving any changes.

### Save Changes

Save changes done so far to any of the setup options.

### Discard Changes

Discard changes done so far to any of the setup options.

### Load Optimized Defaults

Restore/load default values for all the setup options.

### Boot Override

These items displays the available devices. The device items that appears on the screen depends on the number of devices installed in the system. Click an item to start booting from the selected device.



# Driver Installation

# 5

This chapter provides instructions for installing the necessary drivers for different system components.

## 5.1 Running the Support DVD

The support DVD that is bundled with your motherboard contains drivers, management applications, and utilities that you can install to maximize the features of your motherboard.



---

The contents of the support DVD are subject to change at any time without notice. Visit [www.asus.com](http://www.asus.com) for the latest updates on software and utilities.

---

The main screen of the Support DVD contains the following tabs:

1. Drivers - Shows the available device drivers that the system detects.
2. Utilities - Displays the software applications and utilities that the motherboard supports.
3. Manual - Provides the link to the user guide(s).



---

You need an internet browser installed in your OS to view the User Guide.

---

4. Contact - Displays the ASUS contact information, e-mail addresses, and useful links if you need more information or technical support for your motherboard.

# Appendix

This appendix includes additional information that you may refer to when configuring the motherboard.

# Block diagram

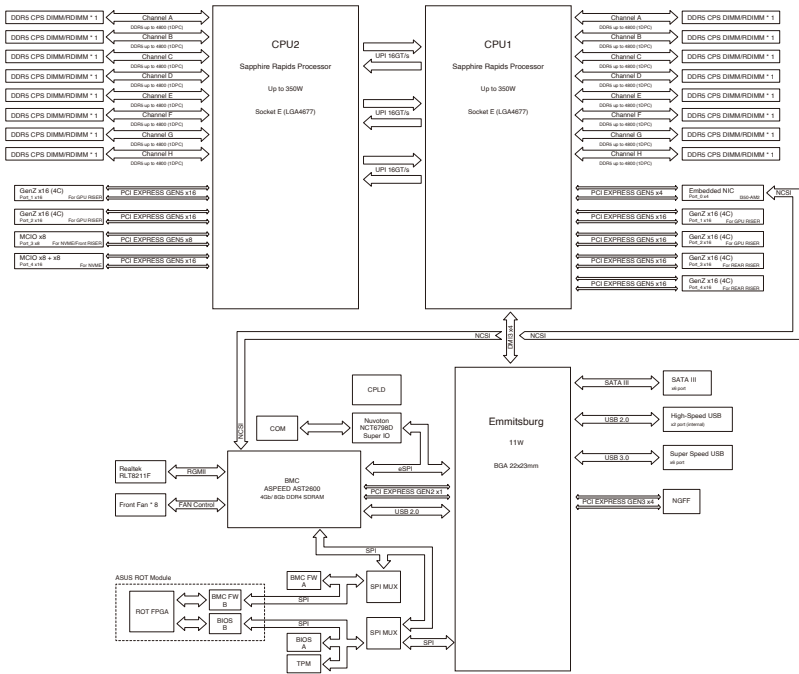

# Q-Code table

ACTION	PHASE	POST CODE	TYPE	DESCRIPTION
Normal boot	Security Phase	01	Progress	First post code(POWER_ON_POST_CODE)
		02	Progress	Load BSP microcode(MICROCODE_POST_CODE)
		03	Progress	Set cache as ram for PEI phase(CACHE_ENABLED_POST_CODE)
		06	Progress	CPU Early init.(CPU_EARLY_INIT_POST_CODE)
		04	Progress	initializes South bridge for PEI preparation
	PEI(Pre-EFI initialization) phase	10	Progress	PEI Core Entry
		15	Progress	NB initialize before installed memory
		19	Progress	SB initialize before installed memory
		78-00	Progress	Wait BMC ready(duration: 120 seconds).
		A1	MRC Progress	QPI initialization
		A3	MRC Progress	QPI initialization
		A7	MRC Progress	QPI initialization
		A8	MRC Progress	QPI initialization
		A9	MRC Progress	QPI initialization
		AA	MRC Progress	QPI initialization
		AB	MRC Progress	QPI initialization
		AC	MRC Progress	QPI initialization
		AD	MRC Progress	QPI initialization
		AE	MRC Progress	QPI initialization
		AF	MRC Progress	QPI initialization Complete
		2F	Progress	Memory Init.
		B0	MRC Progress	Memory Init.
		B1	MRC Progress	Memory Init.
		AF	MRC Progress	RC Reset if require
		B4	MRC Progress	Memory Init.
		B2	MRC Progress	Memory Init.
		B3	MRC Progress	Memory Init.
		B5	MRC Progress	Memory Init.
		B6	MRC Progress	Memory Init.
		B7	MRC Progress	Memory Init.
	B8	MRC Progress	Memory Init.	
	B9	MRC Progress	Memory Init.	
BA	MRC Progress	Memory Init.		

(continued on the next page)

ACTION	PHASE	POST CODE	TYPE	DESCRIPTION
Normal boot	PEI(Pre-EFI initialization) phase	BB	MRC Progress	Memory Init.
		BC	MRC Progress	Memory Init.
		BF	MRC Progress	Memory Init. Done
		5A	MRC Progress	Other config. After RC end
		31	Progress	Memory already installed.
		32	Progress	CPU Init.
		34	Progress	CPU Init.
		36	Progress	CPU Init.
		4F	Progress	DXE Initial Program Load(IPL)
	DXE(Driver Execution Environment) phase	60	Progress	DXE Core Started
		61	Progress	DXE NVRAM Init.
		62	Progress	SB run-time init.
		63	Progress	DXE CPU Init
		68	Progress	NB Init.
		69	Progress	NB Init.
		6A	Progress	NB Init.
		70	Progress	SB Init.
		71	Progress	SB Init.
		72	Progress	SB Init.
	BDS(Boot Device Selection) phase	78	Progress	ACPI Init.
		79	Progress	CSM Init.
		90	Progress	BDS started
		91	Progress	Connect device event
		92	Progress	PCI Bus Enumeration.
		93	Progress	PCI Bus Enumeration.
		94	Progress	PCI Bus Enumeration.
		95	Progress	PCI Bus Enumeration.
		96	Progress	PCI Bus Enumeration.
		97	Progress	Console outout connect event
		98	Progress	Console input connect event
		99	Progress	AMI Super IO start
		9A	Progress	AMI USB Driver Init.
		9B	Progress	AMI USB Driver Init.
		9C	Progress	AMI USB Driver Init.
		9D	Progress	AMI USB Driver Init.
		b2	Progress	Legacy Option ROM Init.
		b3	Progress	Reset system
		b4	Progress	USB hotplug
		b6	Progress	NVRAM clean up
		b7	Progress	NVRAM configuration reset
		A0	Progress	IDE, AHCI Init.
		A1	Progress	IDE, AHCI Init.
A2	Progress	IDE, AHCI Init.		
A3	Progress	IDE, AHCI Init.		
A8	Progress	BIOS Setup Utility password verify		
A9	Progress	BIOS Setup Utility start		
AB	Progress	BIOS Setup Utility input wait		
AD	Progress	Ready to boot event		
AE	Progress	Legacy boot event		
Operating system phase	AA	Progress	APIC mode	
	AC	Progress	PIC mode	



## Notices

### Federal Communications Commission Statement

This device complies with Part 15 of the FCC Rules. Operation is subject to the following two conditions:

- This device may not cause harmful interference.
- This device must accept any interference received including interference that may cause undesired operation.

This equipment has been tested and found to comply with the limits for a Class A digital device, pursuant to part 15 of the FCC Rules. These limits are designed to provide reasonable protection against harmful interference when the equipment is operated in a commercial environment. This equipment generates, uses, and can radiate radio frequency energy and, if not installed and used in accordance with the instruction manual, may cause harmful interference to radio communications. Operation of this equipment in a residential area is likely to cause harmful interference in which case the user will be required to correct the interference at his own expense.



---

The use of shielded cables for connection of the monitor to the graphics card is required to assure compliance with FCC regulations. Changes or modifications to this unit not expressly approved by the party responsible for compliance could void the user's authority to operate this equipment.

---

### Compliance Statement of Innovation, Science and Economic Development Canada (ISED)

This device complies with Innovation, Science and Economic Development Canada licence exempt RSS standard(s). Operation is subject to the following two conditions: (1) this device may not cause interference, and (2) this device must accept any interference, including interference that may cause undesired operation of the device.

CAN ICES-003(A)/NMB-003(A)

### Déclaration de conformité de Innovation, Sciences et Développement économique Canada (ISED)

Le présent appareil est conforme aux CNR d'Innovation, Sciences et Développement économique Canada applicables aux appareils radio exempts de licence. L'exploitation est autorisée aux deux conditions suivantes : (1) l'appareil ne doit pas produire de brouillage, et (2) l'utilisateur de l'appareil doit accepter tout brouillage radioélectrique subi, même si le brouillage est susceptible d'en compromettre le fonctionnement.

CAN ICES-003(A)/NMB-003(A)

### Japan JATE

本製品は電気通信事業者（移动通信会社、固定通信会社、インターネットプロバイダ等）の通信回線（公衆無線LANを含む）に直接接続することができません。本製品をインターネットに接続する場合は、必ずルータ等を経由し接続してください。」等が考えられる。

## Japan statement notice

This product cannot be directly connected to the Internet (including public wireless LAN) of a telecom carrier (mobile network companies, landline network companies, Internet providers, etc.). When connecting this product to the Internet, be sure to connect it through a router or switch.

## Australia statement notice

From 1 January 2012 updated warranties apply to all ASUS products, consistent with the Australian Consumer Law. For the latest product warranty details please visit <https://www.asus.com/support/>. Our goods come with guarantees that cannot be excluded under the Australian Consumer Law. You are entitled to a replacement or refund for a major failure and compensation for any other reasonably foreseeable loss or damage. You are also entitled to have the goods repaired or replaced if the goods fail to be of acceptable quality and the failure does not amount to a major failure.

If you require assistance please call ASUS Customer Service 1300 2787 88 or visit us at <https://www.asus.com/support/>.



---

DO NOT throw the motherboard in municipal waste. This product has been designed to enable proper reuse of parts and recycling. This symbol of the crossed out wheeled bin indicates that the product (electrical and electronic equipment) should not be placed in municipal waste. Check local regulations for disposal of electronic products.

---



---

DO NOT throw the mercury-containing button cell battery in municipal waste. This symbol of the crossed out wheeled bin indicates that the battery should not be placed in municipal waste.

---

## Declaration of compliance for product environmental regulation

ASUS follows the green design concept to design and manufacture our products, and makes sure that each stage of the product life cycle of ASUS product is in line with global environmental regulations. In addition, ASUS disclose the relevant information based on regulation requirements.

Please refer to <http://csr.asus.com/Compliance.htm> for information disclosure based on regulation requirements ASUS is complied with:

### EU REACH and Article 33

Complying with the REACH (Registration, Evaluation, Authorization, and Restriction of Chemicals) regulatory framework, we publish the chemical substances in our products at ASUS REACH website at <http://csr.asus.com/english/REACH.htm>.

### EU RoHS

This product complies with the EU RoHS Directive. For more details, see <http://csr.asus.com/english/article.aspx?id=35>

### Japan JIS-C-0950 Material Declarations

Information on Japan RoHS (JIS-C-0950) chemical disclosures is available on <http://csr.asus.com/english/article.aspx?id=19>

## India RoHS

This product complies with the "India E-Waste (Management) Rules, 2016" and prohibits use of lead, mercury, hexavalent chromium, polybrominated biphenyls (PBBs) and polybrominated diphenyl ethers (PBDEs) in concentrations exceeding 0.1% by weight in homogenous materials and 0.01% by weight in homogenous materials for cadmium, except for the exemptions listed in Schedule II of the Rule.

## Vietnam RoHS

ASUS products sold in Vietnam, on or after September 23, 2011, meet the requirements of the Vietnam Circular 30/2011/TT-BCT.

Các sản phẩm ASUS bán tại Việt Nam, vào ngày 23 tháng 9 năm 2011 trở về sau, đều phải đáp ứng các yêu cầu của Thông tư 30/2011/TT-BCT của Việt Nam.

## Türkiye RoHS

AEEE Yönetmeliğine Uygundur

## ASUS Recycling/Takeback Services

ASUS recycling and takeback programs come from our commitment to the highest standards for protecting our environment. We believe in providing solutions for you to be able to responsibly recycle our products, batteries, other components as well as the packaging materials. Please go to <http://csr.asus.com/english/Takeback.htm> for detailed recycling information in different regions.

## Ecodesign Directive

European Union announced a framework for the setting of ecodesign requirements for energy-related products (2009/125/EC). Specific Implementing Measures are aimed at improving environmental performance of specific products or across multiple product types. ASUS provides product information on the CSR website. The further information could be found at <https://csr.asus.com/english/article.aspx?id=1555>.

## KC: Korea Warning Statement



R-R-MSQ-ESC4000-E11

이 기기는 업무용 환경에서 사용할 목적으로 적합성평가를 받은 기기로서 가정용 환경에서 사용하는 경우 전파간섭의 우려가 있습니다.

## Safety Precautions

Accessories that came with this product have been designed and verified for the use in connection with this product. Never use accessories for other products to prevent the risk of electric shock or fire.

## 安全上のご注意

付属品は当該専用品です。他の機器には使用しないでください。機器の破損もしくは、火災や感電の原因となることがあります。

# Service and Support

Visit our multi-language website at <https://www.asus.com/support/>

