

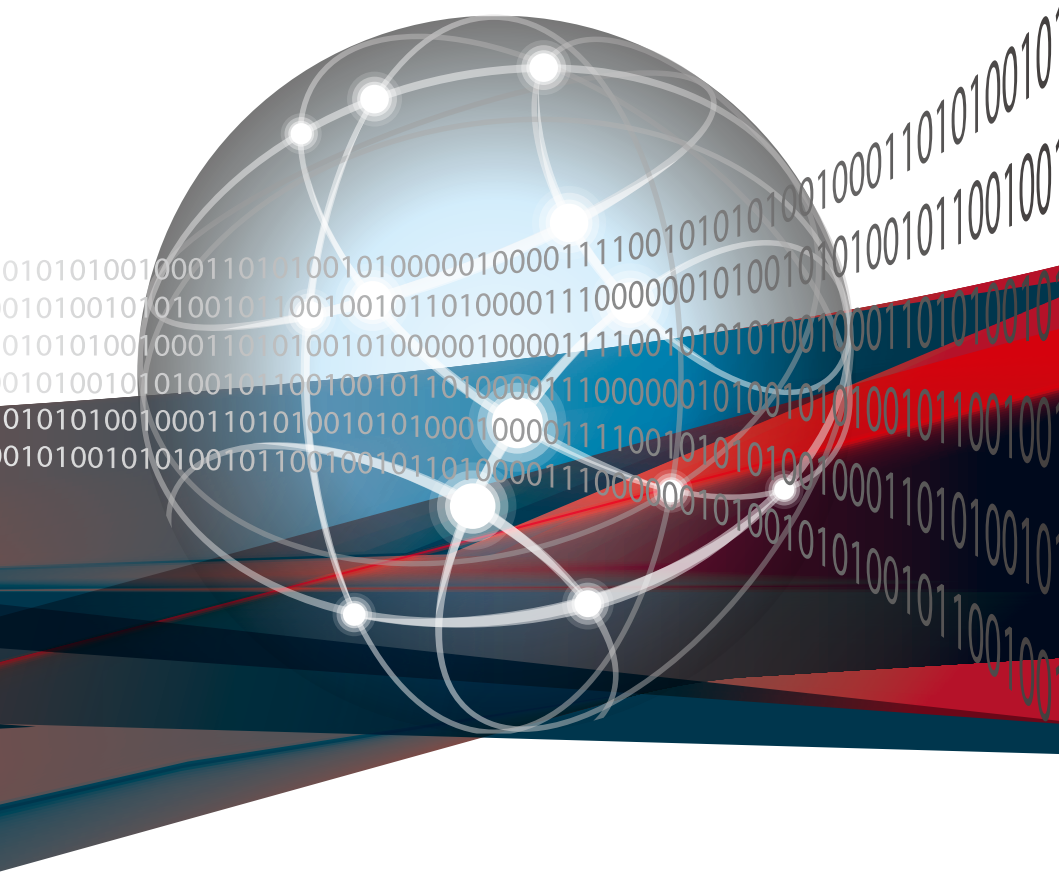

# ESC4000A-E10

## 2U Rackmount Server User Guide



E21771  
Revised Edition V9  
March 2023

**Copyright © 2023 ASUSTeK COMPUTER INC. All Rights Reserved.**

No part of this manual, including the products and software described in it, may be reproduced, transmitted, transcribed, stored in a retrieval system, or translated into any language in any form or by any means, except documentation kept by the purchaser for backup purposes, without the express written permission of ASUSTeK COMPUTER INC. ("ASUS").

ASUS provides this manual "as is" without warranty of any kind, either express or implied, including but not limited to the implied warranties or conditions of merchantability or fitness for a particular purpose. In no event shall ASUS, its directors, officers, employees, or agents be liable for any indirect, special, incidental, or consequential damages (including damages for loss of profits, loss of business, loss of use or data, interruption of business and the like), even if ASUS has been advised of the possibility of such damages arising from any defect or error in this manual or product.

Specifications and information contained in this manual are furnished for informational use only, and are subject to change at any time without notice, and should not be construed as a commitment by ASUS. ASUS assumes no responsibility or liability for any errors or inaccuracies that may appear in this manual, including the products and software described in it.

Product warranty or service will not be extended if: (1) the product is repaired, modified or altered, unless such repair, modification or alteration is authorized in writing by ASUS; or (2) the serial number of the product is defaced or missing.

Products and corporate names appearing in this manual may or may not be registered trademarks or copyrights of their respective companies, and are used only for identification or explanation and to the owners' benefit, without intent to infringe.

# Contents

Safety information.....	vi
About this guide.....	viii

## Chapter 1: Product Introduction

1.1	System package contents.....	1-2
1.2	Serial number label.....	1-2
1.3	System specifications .....	1-3
1.4	Front panel features.....	1-5
1.5	Rear panel features.....	1-5
1.6	Internal features .....	1-6
1.7	LED information .....	1-7
1.7.1	Front panel LEDs .....	1-7
1.7.2	LAN (RJ-45) LEDs .....	1-8
1.7.3	HDD status LEDs.....	1-9
1.7.4	Q-Code/Port 80 status LEDs.....	1-10

## Chapter 2: Hardware Setup

2.1	Chassis cover.....	2-2
2.1.1	Air duct.....	2-4
2.2	Central Processing Unit (CPU) .....	2-5
2.2.1	Installing the CPU and heatsink .....	2-5
2.3	System memory .....	2-9
2.3.1	Overview .....	2-9
2.3.2	Memory Configurations.....	2-9
2.4	Hard disk drives .....	2-11
2.4.1	Installing the 3.5-inch SATA HDD/SAS HDD.....	2-11
2.4.2	Installing the 2.5-inch SSD/SATA HDD/SAS HDD/NVMe.....	2-12
2.5	Expansion slots.....	2-13
2.5.1	The PCI Express riser card.....	2-13
2.5.2	Installing an ASUS PIKE II card.....	2-16
2.5.3	Reconnecting the cable to the M.2 expansion board (only for SKU-3) .....	2-22
2.5.4	Installing an M.2 (NGFF) card.....	2-24
2.5.5	Reconnecting the cable to the OCP 3.0 slot baseboard (only for SKU-2) .....	2-25
2.5.6	Configuring an expansion card .....	2-27
2.6	Cable connections .....	2-28
2.7	SATA/SAS backplane cabling.....	2-29

# Contents

<b>2.8</b>	<b>Removable/optional components</b> .....	<b>2-30</b>
2.8.1	Cable organizer metal cover .....	2-30
2.8.2	System fans .....	2-31
2.8.3	Redundant power supply units.....	2-32
2.8.4	U.2 drives .....	2-34
2.8.5	GPU cards.....	2-36
<b>2.9</b>	<b>Rail Kit Options</b> .....	<b>2-40</b>

## Chapter 3: Motherboard Information

<b>3.1</b>	<b>KRPG-U8 Motherboard layout</b> .....	<b>3-2</b>
<b>3.2</b>	<b>Jumpers</b> .....	<b>3-4</b>
<b>3.3</b>	<b>Internal connectors</b> .....	<b>3-8</b>
<b>3.4</b>	<b>Onboard LEDs</b> .....	<b>3-16</b>

## Chapter 4: BIOS Setup

<b>4.1</b>	<b>Managing and updating your BIOS</b> .....	<b>4-2</b>
4.1.1	ASUS CrashFree BIOS 3 utility.....	4-2
4.1.2	ASUS EZ Flash Utility .....	4-3
4.1.3	BUPDATER utility .....	4-4
<b>4.2</b>	<b>BIOS setup program</b> .....	<b>4-6</b>
4.2.1	BIOS menu screen.....	4-7
4.2.2	Menu bar .....	4-7
<b>4.3</b>	<b>Main menu</b> .....	<b>4-9</b>
<b>4.4</b>	<b>Performance Tuning menu</b> .....	<b>4-10</b>
<b>4.5</b>	<b>Advanced menu</b> .....	<b>4-12</b>
4.5.1	Trusted Computing.....	4-12
4.5.2	PSP Firmware Versions .....	4-13
4.5.3	APM Configuration .....	4-13
4.5.4	Onboard LAN Configuration .....	4-14
4.5.5	Serial Port Console Redirection .....	4-15
4.5.6	CPU Configuration .....	4-17
4.5.7	PCI Subsystem Settings .....	4-18
4.5.8	USB Configuration .....	4-19
4.5.9	Network Stack Configuration.....	4-20

# Contents

4.5.10	CSM Configuration .....	4-21
4.5.11	NVMe Configuration .....	4-22
4.5.12	SATA Configuration .....	4-22
4.5.13	AMD Mem Configuration Status .....	4-23
4.5.14	iSCSI Configuration .....	4-23
<b>4.6</b>	<b>Chipset menu .....</b>	<b>4-24</b>
<b>4.7</b>	<b>Security menu .....</b>	<b>4-25</b>
<b>4.8</b>	<b>Boot menu .....</b>	<b>4-28</b>
<b>4.9</b>	<b>Tool menu .....</b>	<b>4-29</b>
<b>4.10</b>	<b>Save &amp; Exit menu .....</b>	<b>4-30</b>
<b>4.11</b>	<b>AMD CBS menu .....</b>	<b>4-31</b>
4.11.1	CPU Common Options .....	4-31
4.11.2	DF Common Options .....	4-33
4.11.3	UMC Common Option .....	4-35
4.11.4	NBIO Common Options .....	4-40
4.11.5	NTB Common Options .....	4-44
<b>4.12</b>	<b>Event Logs menu .....</b>	<b>4-45</b>
4.12.1	Change Smbios Event Log Settings .....	4-45
4.12.2	View Smbios Event Log .....	4-46
<b>4.13</b>	<b>Server Mgmt menu .....</b>	<b>4-47</b>

## Chapter 5: Driver Installation

<b>5.1</b>	<b>Running the Support DVD .....</b>	<b>5-2</b>
------------	--------------------------------------	------------

## Appendix

KRPG-U8 block diagram .....	A-2
Notices .....	A-3
Service and Support .....	A-5

# Safety information

## Electrical Safety

- Before installing or removing signal cables, ensure that the power cables for the system unit and all attached devices are unplugged.
- To prevent electrical shock hazard, disconnect the power cable from the electrical outlet before relocating the system.
- When adding or removing any additional devices to or from the system, ensure that the power cables for the devices are unplugged before the signal cables are connected. If possible, disconnect all power cables from the existing system before you add a device.
- If the power supply is broken, do not try to fix it by yourself. Contact a qualified service technician or your dealer.

## Operation Safety

- Any mechanical operation on this server must be conducted by certified or experienced engineers.
- Before operating the server, carefully read all the manuals included with the server package.
- Before using the server, ensure all cables are correctly connected and the power cables are not damaged. If any damage is detected, contact your dealer as soon as possible.
- To avoid short circuits, keep paper clips, screws, and staples away from connectors, slots, sockets and circuitry.
- Avoid dust, humidity, and temperature extremes. Place the server on a stable surface.



---

This product is equipped with a three-wire power cable and plug for the user's safety. Use the power cable with a properly grounded electrical outlet to avoid electrical shock.

---

## Restricted Access Location

This product is intended for installation only in a Computer Room where:

- Access can only be gained by **SERVICE PERSONS** or by **USERS** who have been instructed about the reasons for the restrictions applied to the location and about any precautions that shall be taken.
- Access is through the use of a **TOOL**, or other means of security, and is controlled by the authority responsible for the location.

### Heavy System

**CAUTION!** This server system is heavy. Ask for assistance when moving or carrying the system.

### Lithium-Ion Battery Warning

**CAUTION:** Danger of explosion if battery is incorrectly replaced. Replace only with the same or equivalent type recommended by the manufacturer. Dispose of used batteries according to the manufacturer's instructions.

### Avertissement sur les batteries Lithium-Ion

**ATTENTION :** Danger d'explosion si la batterie n'est pas correctement remplacée. Remplacer uniquement avec une batterie de type semblable ou équivalent, recommandée par le fabricant. Jeter les batteries usagées conformément aux instructions du fabricant.

# About this guide

## Audience

This user guide is intended for system integrators, and experienced users with at least basic knowledge of configuring a server.

## Contents

This guide contains the following parts:

**1. Chapter 1: Product Introduction**

This chapter describes the general features of the server, including sections on front panel and rear panel specifications.

**2. Chapter 2: Hardware Setup**

This chapter lists the hardware setup procedures that you have to perform when installing or removing system components.

**3. Chapter 3: Motherboard Information**

This chapter gives information about the motherboard that comes with the server. This chapter includes the motherboard layout, jumper settings, and connector locations.

**4. Chapter 4: BIOS Setup**

This chapter tells how to change system settings through the BIOS Setup menus and describes the BIOS parameters.

**5. Chapter 5: Driver Installation**

This chapter provides instructions for installing the necessary drivers for different system components.



## Conventions

To ensure that you perform certain tasks properly, take note of the following symbols used throughout this manual.



**DANGER/WARNING:** Information to prevent injury to yourself when trying to complete a task.



**CAUTION:** Information to prevent damage to the components when trying to complete a task.



**IMPORTANT:** Instructions that you **MUST** follow to complete a task.



**NOTE:** Tips and additional information to help you complete a task.

## Typography

### **Bold text**

Indicates a menu or an item to select.

### *Italics*

Used to emphasize a word or a phrase.

### <Key>

Keys enclosed in the less-than and greater-than sign means that you must press the enclosed key.

Example: <Enter> means that you must press the Enter or Return key.

### <Key1>+<Key2>+<Key3>

If you must press two or more keys simultaneously, the key names are linked with a plus sign (+).

Example: <Ctrl>+<Alt>+<Del>

### **Command**

Means that you must type the command exactly as shown, then supply the required item or value enclosed in brackets.

Example: At the DOS prompt,  
type the command line: **format A: /S**

## References

Refer to the following sources for additional information, and for product and software updates.

### 1. **ASUS Control Center (ACC) user guide**

This manual tells how to set up and use the proprietary ASUS server management utility.

### 2. **ASUS websites**

The ASUS websites provide updated information for all ASUS hardware and software products. Visit <https://www.asus.com> for more information.



# Product Introduction

# 1

This chapter describes the general features of the chassis kit. It includes sections on front panel and rear panel specifications.

# 1.1 System package contents

Check your system package for the following items.

ESC4000A-E10	
Chassis	ASUS 2U Rackmount Chassis
Motherboard	ASUS KRPG-U8 Server Board
Accessory box	1 x MB Support DVD 1 x ACC instruction card 1 x Bag of Screws 2 x AC Power Cables 8 x 6+2-pin VGA Power cables 4 x ASUS GPU 8-pin Power cables 4 x GPU air ducts (for Nvidia/AMD cards) 1 x CPU heatsink 1 x Rail Kit (optional)



- If any of the above items is damaged or missing, contact your retailer.
- Optional items come bundled if you selected them when purchasing the system and cannot be bought separately.

# 1.2 Serial number label

Before requesting support from the ASUS Technical Support team, you must take note of the product's serial number containing 12 characters such as xxSxxxxxxx. See the figure below.

With the correct serial number of the product, ASUS Technical Support team members can then offer a quicker and satisfying solution to your problems.



The serial number is printed on the Asset tag.

## 1.3 System specifications

The ASUS ESC4000A-E10 Series servers features the ASUS KRPG-U8 server board that supports AMD EPYC™ 7002 & 7003 Series Processor Family.

Model Name		ESC4000A-E10
Processor / System Bus		AMD EPYC™ 7002 & 7003 Series Processor Family (up to TDP 280W)
Memory	Total Slots	8 (8-channel per CPU, 8 DIMM per CPU)
	Capacity	Up to 2TB
	Memory Type	DDR4 3200 RDIMM
	Memory Size	256GB, 128GB, 64GB, 32GB, 16GB* * Please refer to <a href="http://www.asus.com">www.asus.com</a> for latest memory AVL update
Expansion Slots	Total PCI/PCI-X/PCI-E/PIKE Slots	11
	Slot Type	<b>Rear:</b> - 4 x PCIe x16 slots (Gen4 x16 link, FH,FL) or 8 x PCIe x16 slots (Gen4 x8 link, FH,FL) - 2 x PCIe x16 slots (Gen4 x16 link, LP,HL) <b>Front:</b> <u>SKU-1 (default)</u> - 1 x PCIe x8 slot (Gen4 x8 link, LP,HL) <u>SKU-2 (per request)</u> - 1 x PCIe x8 slot (Gen4 x8 link, LP,HL) or 1 x OCP3.0 slot (Gen4 x8 link) by reconnecting the cables <u>SKU-3 (per request)</u> - 1 x PCIe x8 slot (Gen4 x8 link, LP,HL) or 2 x M.2 socket (Gen4 x4 link, up to 22110 module) by reconnecting the cables
Storage Bays		8 x 2.5" or 3.5" Hot-swap Storage Device Bays (2 x NVMe as default; up to 4 x NVMe Supported)
Networking	LAN	2 x 1Gb/s LAN ports (Intel® I350-AM2)
		1 x Dedicated management port
Graphic	VGA	AST2500 64MB
Security		TPM2.0
Front I/O ports		4 x USB 3.2 Gen 1 ports
Rear I/O ports		2 x USB 3.2 Gen 1 ports
		2 x Gigabit LAN ports (RJ45)
		1 x Management port (RJ45)
		1 x VGA port

(continued on the next page)

# System specifications

Model Name		ESC4000A-E10
Switch/LED		<b>Front Switch/LED:</b> 1 x Power Switch/LED 1 x Location Switch/LED 1 x HDD Access LED 1 x Message LED 1 x Q-Code/Port 80 LED 2 x LAN LED  <b>Rear Switch/LED:</b> 1 x Power switch/LED 1 x Location LED 1 x Message LED 1 x HDD Access LED
OS Support		Windows® Server 2019, RedHat®, SuSE®, Ubuntu, Vmware * Please find the latest OS support from <a href="http://www.asus.com/">http://www.asus.com/</a>
Management Solution	Out of Band Remote Hardware	On-Board ASMB9-iKVM for KVM-over-IP
	Software	ASUS Control Center
Dimension		800mm x 440mm x 88.9mm (2U) 31.50" x 17.22" x 3.46"
Net Weight Kg (CPU, DRAM & HDD not included)		34 kg
Gross Weight Kg (CPU, DRAM & HDD not included, Packing include)		44 kg
Power Supply (following different configuration by region)		1+1 Redundant 1600W 80 PLUS Platinum Power Supply 1+1 Redundant 2200W 80 PLUS Platinum Power Supply
Environment		Operation temperature: 10° ~ 35° Non operation temperature: -40° ~ 70° Non operation humidity: 20% ~ 90% ( Non condensing)



Always use PSUs with the same watt and power rating. Combining PSUs with different wattage (e.g. 1 x 1600 W + 1 x 2200 W) may yield unstable results and potential damage to your system.



Specifications are subject to change without notice.

## 1.4 Front panel features

The barebone server features a simple yet stylish front panel. The power and location buttons, LED indicators, and USB ports are located and easily accessible on the front panel.



Refer to the **Front panel LEDs** section for the LED descriptions.

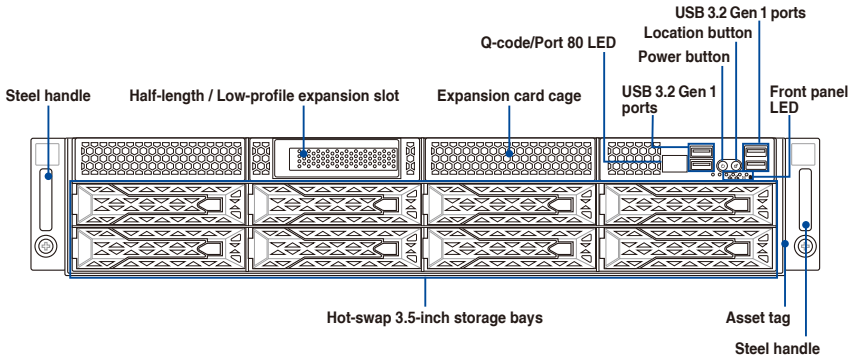

## 1.5 Rear panel features

The expansion slots and system power socket is located on the rear panel of the server. The middle part includes the I/O shield with openings for the rear panel connectors on the motherboard.

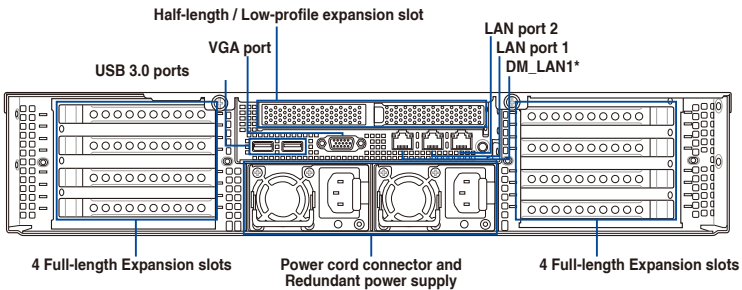

- The rear I/O ports do not appear on the rear panel if motherboard is not present.
- \*The DM\_LAN1 port is for ASUS ASMB9-iKVM controller only.

## 1.6 Internal features

The barebone server includes the basic components as shown.

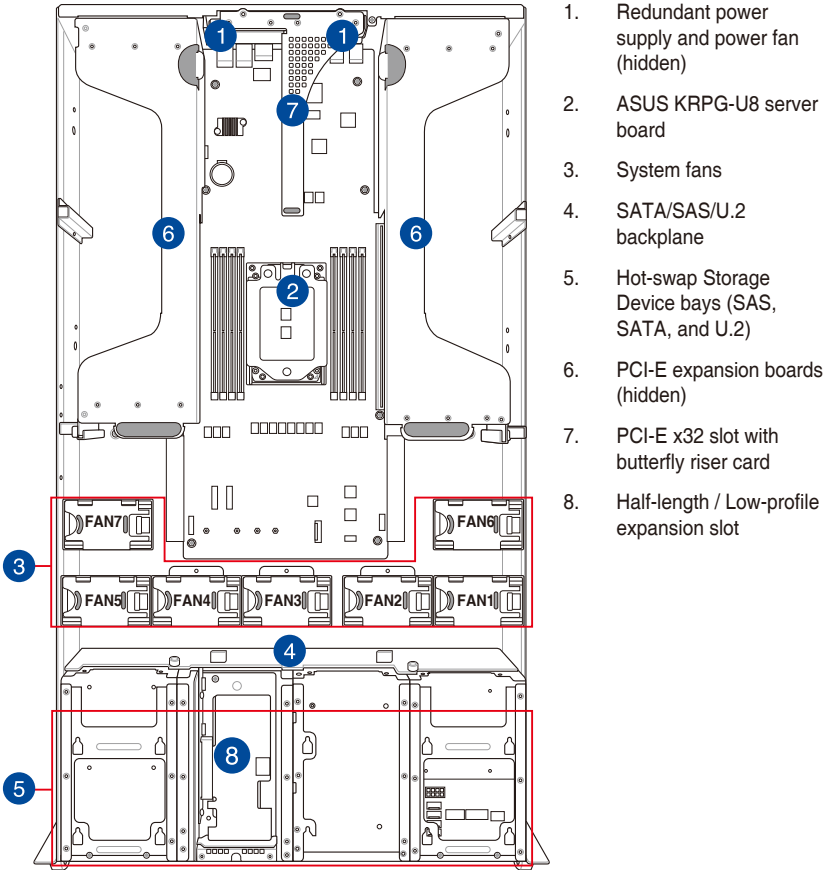

A protection film is pre-attached to the front cover before shipping. Please remove the protection film before turning on the system for proper heat dissipation.

### WARNING

HAZARDOUS MOVING PARTS  
KEEP FINGERS AND OTHER BODY PARTS AWAY



# 1.7 LED information

## 1.7.1 Front panel LEDs

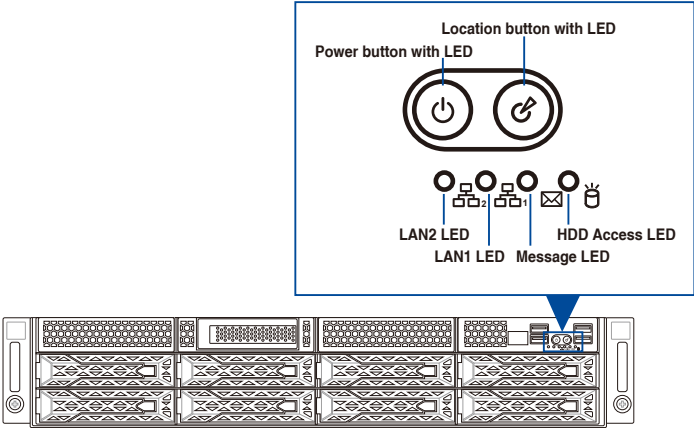

LED	Icon	Display status	Description
Power button with LED		ON	System power on
HDD access LED		OFF	No activity
		Blinking	Data activity
Message LED		OFF	System is normal; no incoming event
		ON	A hardware monitor event is indicated
Location button with LED		OFF	Function off
		ON	Location switch is pressed (Press the location switch again to turn off)
LAN LEDs		OFF	No LAN connection
		Blinking	LAN is transmitting or receiving data
		ON	LAN connection is present

## 1.7.2 LAN (RJ-45) LEDs

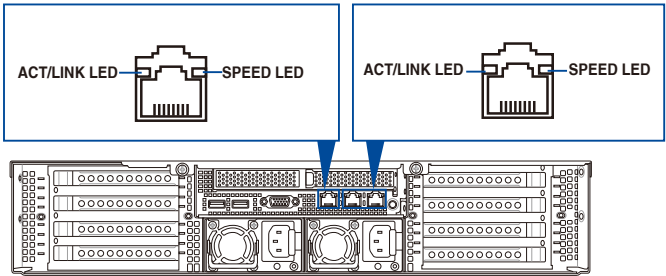

### LAN1/LAN2 LEDs

ACT/LINK LED		SPEED LED	
Status	Description	Status	Description
OFF	No link	OFF	10 Mbps connection
GREEN	Linked	ORANGE	100 Mbps connection
BLINKING	Data activity	GREEN	1 Gbps connection

### Dedicated Management LAN (for ASMB9 and DM\_LAN1)

ACT/LINK LED		SPEED LED	
Status	Description	Status	Description
OFF	No link	OFF	10 Mbps connection
ORANGE	Linked	ORANGE	100 Mbps connection
BLINKING	Data activity	GREEN	1 Gbps connection

### 1.7.3 HDD status LEDs

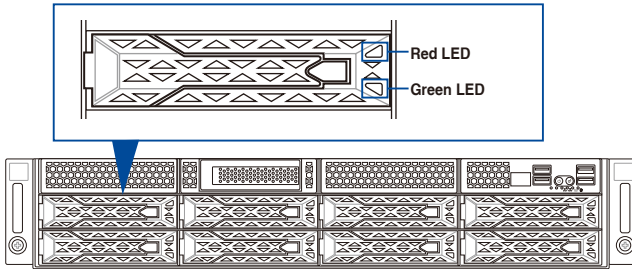

SATA/SAS HDD LED Description		
GREEN	ON	SATA/SAS HDD power ON
RED	ON	HDD has failed and should be swapped immediately
GREEN/ RED	Blinking	RAID rebuilding
GREEN/ RED	Blinking	Locate
GREEN/ RED	OFF	HDD not found
GREEN	Blinking	SATA/SAS storage device reading or writing data

## 1.7.4 Q-Code/Port 80 status LEDs

The Q-Code LED provides a 2-digit display that shows the status of your system. Refer to the **Q-Code** table of this user guide for more information about the 2-digit codes.

**Q-Code table**

ACTION	PHASE	POST CODE	TYPE	DESCRIPTION
SEC Start up	Security Phase	0x1	Progress	First post code
		0x2	Progress	Load BSP microcode
		0x3	Progress	Perform early platform Initialization
		0x4	Progress	Set cache as ram for PEI phase
		0x5	Progress	Establish Stack
		0x6	Progress	CPU Early Initialization
	PEI(Pre-EFI Initialization) phase	0x10	Progress	PEI Core Entry
		0x11	Progress	PEI cache as ram CPU initial
		0x15	Progress	NB Initialization before installed memory
		0x19	Progress	SB Initialization before installed memory
		0x20	Progress	SB Initialization after installed memory
	MRC Progress phase	0xB0	MRC Progress	DIMM detect
		0xB1	MRC Progress	DIMM clock Initialization
		0xB2	MRC Progress	DIMM SPD data Initialization
		0xB3	MRC Progress	DIMM global early
		0xB4	MRC Progress	DIMM rank detect
		0xB5	MRC Progress	DIMM channel early
		0xB6	MRC Progress	DIMM DDRI0 Initialization
		0xB7	MRC Progress	DIMM channel training
		0xB8	MRC Progress	DIMM Initialization throttling
		0xB9	MRC Progress	memory BIST
		0xBA	MRC Progress	MEM memory Initialization
		0xBB	MRC Progress	DIMM DDR memory map
		0xBC	MRC Progress	RAS configuration
		0xBD	MRC Progress	Get Margins
0xBE	MRC Progress	Memory SSA api Initialization		
0xBF	MRC Progress	MRC done		
Quick VGA		0x32	Progress	CPU POST-Memory Initialization
		0x33	Progress	CPU Cache Initialization
		0x34	Progress	Application Processor(s) (AP) Initialization
		0x35	Progress	BSP Selection
		0x36	Progress	CPU Initialization
		0x37	Progress	Pre-memory NB Initialization
		0x3B	Progress	Pre-memory SB Initialization
		0x4F	Progress	DXE Initial Program Load(IPL)
		0x60	Progress	DXE Core Started
		0x61	Progress	DXE NVRAM Initialization
	DXE(Driver Execution Environment) phase	0x62	Progress	SB run-time Initialization
		0x63	Progress	CPU DXE Initialization
		0x68	Progress	PCI HB Initialization
		0x69	Progress	NB DXE Initialization
		0x6A	Progress	NB DXE SMM Initialization
		0x70	Progress	SB DXE Initialization
		0x71	Progress	SB DXE SMM Initialization
		0x72	Progress	SB DEVICES Initialization
		0x78	Progress	ACPI Module Initialization
		0x79	Progress	CSM Initialization
		0xD0	Progress	CPU PM Structure Initialization
		0xD1	Progress	CPU PM CSR programming
		0xD2	Progress	CPU PM MSR programming
		0xD3	Progress	CPU PM PSTATE transition
		0xD4	Progress	CPU PM driver exit
0xD5	Progress	CPU PM On ready to boot event		

(continued on the next page)

## Q-Code table

ACTION	PHASE	POST CODE	TYPE	DESCRIPTION
Normal boot	BDS(Boot Device Selection) phase	0x90	Progress	BDS started
		0x91	Progress	Connect device event
		0x92	Progress	PCI Bus Enumeration
		0x93	Progress	PCI Bus Enumeration
		0x94	Progress	PCI Bus Enumeration
		0x95	Progress	PCI Bus Enumeration
		0x96	Progress	PCI Bus Enumeration
		0x97	Progress	Console outout connect event
		0x98	Progress	Console input connect event
		0x99	Progress	AMI Super IO start
		0x9A	Progress	AMI USB Driver Initialization
		0x9B	Progress	AMI USB Driver Initialization
		0x9C	Progress	AMI USB Driver Initialization
		0x9D	Progress	AMI USB Driver Initialization
		0xb2	Progress	Legacy Option ROM Initialization
		0xb3	Progress	Reset system
		0xb4	Progress	USB hotplug
		0xb6	Progress	NVRAM clean up
		0xb7	Progress	NVRAM configuration reset
		0xA0	Progress	IDE, AHCI Initialization
		0xA1	Progress	IDE, AHCI Initialization
		0xA2	Progress	IDE, AHCI Initialization
		0xA3	Progress	IDE, AHCI Initialization
		0x00-0xFF	Progress	Wait BMC ready
	0xA8	Progress	BIOS Setup Utility password verify	
	0xA9	Progress	BIOS Setup Utility start	
	0xAB	Progress	BIOS Setup Utility input wait	
	0xAD	Progress	Ready to boot event	
	0xAE	Progress	Legacy boot event	
	Operating system phase	0xAA	Progress	APIC mode
0xAC		Progress	PIC mode	



# Hardware Setup

# 2

This chapter lists the hardware setup procedures that you have to perform when installing or removing system components.

## 2.1 Chassis cover

There are three parts of the chassis cover you may remove.



---

The diagrams in this section are for reference only. The system layout may vary with models, but the installation steps are the same for all models.

---

To remove the rear chassis cover:

1. Release the two (2) thumbscrews on the rear of the chassis.
2. Push and hold the cover buttons down, then slide the chassis cover towards the rear to disengage it from the chassis.
3. Lift the chassis cover to completely remove it from the chassis.

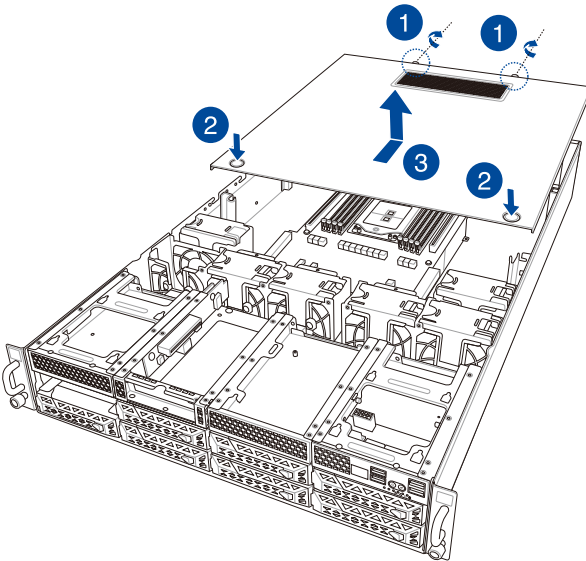



To remove the middle chassis cover:

1. Press the cover latches down on both sides of the middle chassis cover.
2. Lift the chassis cover to completely remove it from the chassis.

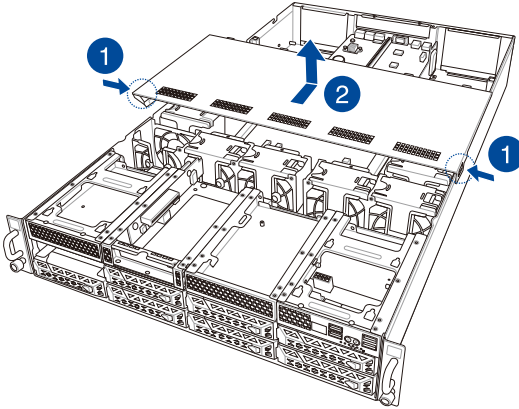

To remove the front chassis cover:

1. Push and hold the cover buttons down, then slide the chassis cover towards the front to disengage it from the chassis.
2. Lift the chassis cover to completely remove it from the chassis.

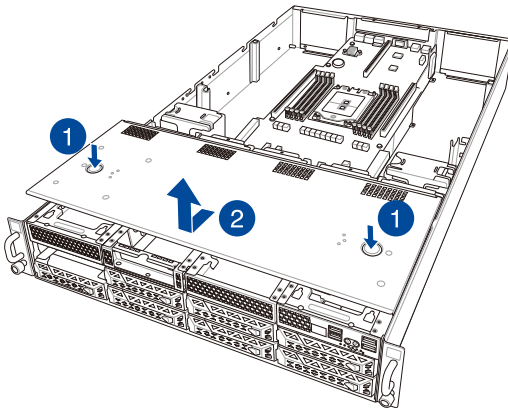

A protection film is pre-attached to the system cover before shipping. Please remove the protection film before turning on the system for proper heat dissipation.

## 2.1.1 Air duct



The diagrams in this section are for reference only. The system layout may vary with models, but the installation steps are the same for all models.

To remove the air duct:

1. Remove the three screws as shown.
2. Lift the air duct to remove it from the chassis.

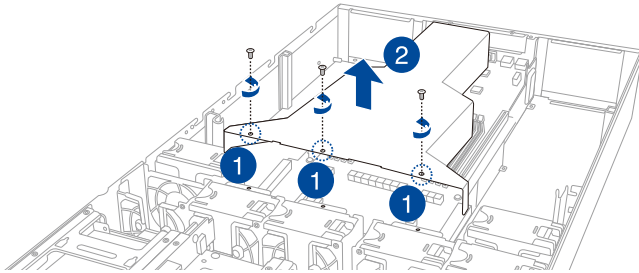

To reinstall the air duct:

1. Align and replace the air duct to the chassis ensuring that the screw holes on the air duct match the screw holes on chassis.
2. Secure the air duct to the chassis with three screws.

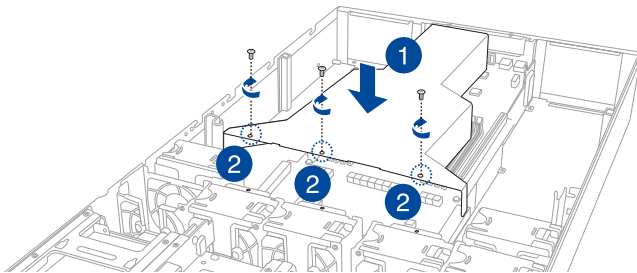

## 2.2 Central Processing Unit (CPU)

The motherboard comes with a surface mount Socket SP3 socket designed for the AMD EPYC™ 7002 & 7003 Series Family processors.



- Upon purchase of the motherboard, ensure that the PnP cap is on the socket and the socket contacts are not bent. Contact your retailer immediately if the PnP cap is missing, or if you see any damage to the PnP cap/socket contacts/motherboard components. ASUS will shoulder the cost of repair only if the damage is shipment/transit-related.
- Keep the cap after installing the motherboard. ASUS will process Return Merchandise Authorization (RMA) requests only if the motherboard comes with the cap on the socket.
- The product warranty does not cover damage to the socket contacts resulting from incorrect CPU installation/removal, or misplacement/loss/incorrect removal of the PnP cap.

### 2.2.1 Installing the CPU and heatsink

1. Remove the rear chassis cover. For more information, see the **Chassis cover** section.
2. Remove the air duct. For more information, see the **Air Duct** section.
3. Locate the CPU socket on the motherboard.

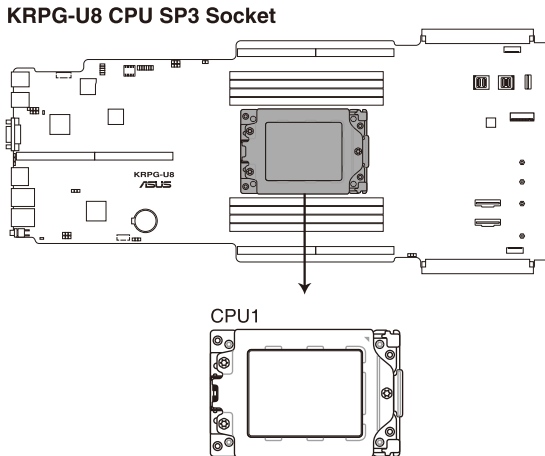

4. Loosen each screw one by one in the sequence shown on the socket to open the load plate.

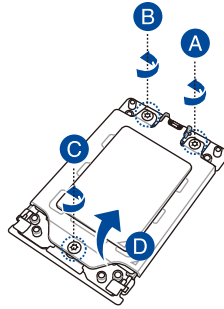

5. Slightly lift open the rail frame.

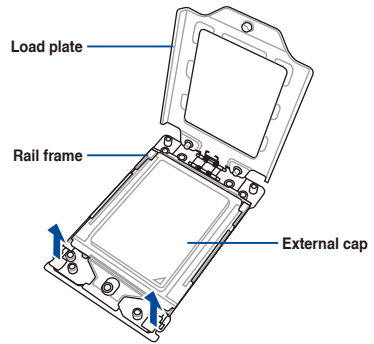

6. Slide the external cap out of the rail frame.

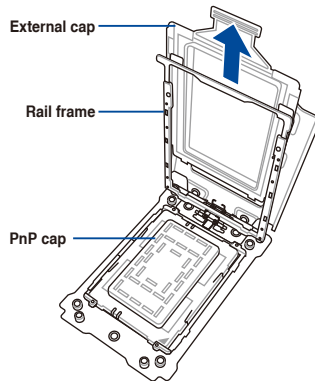

- Slide the carrier frame with CPU into the rail frame, then remove the PnP cap.



The carrier frame with CPU fits in only one correct orientation. DO NOT force the carrier frame with CPU into the rail frame.

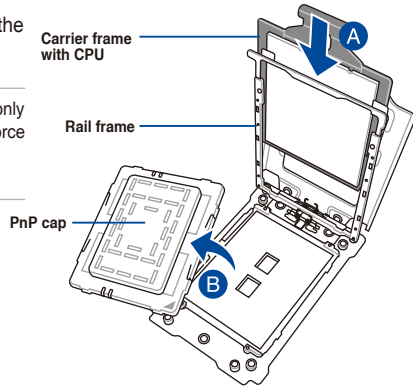

- Gently push the rail frame just enough to let it sit on top of the CPU socket.

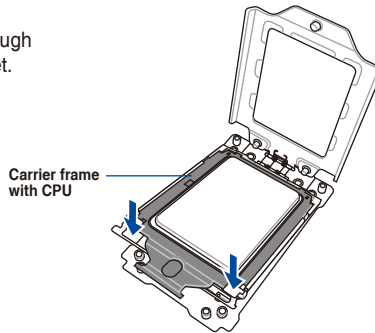

- Close the load plate just enough to let it sit on top of the CPU, then secure each screw one by one in the sequence shown on the socket to completely secure the load plate.



The load plate screws are T20 models. A torque value of  $16.1 \pm 1.2$  kgf-cm ( $14.0 \pm 1.0$  lbf-in) is recommended.

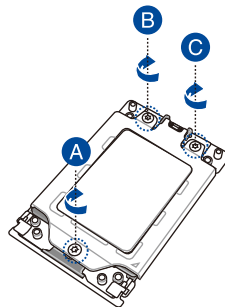

- Twist each of the four screws with a screwdriver in the order shown in the illustration just enough to attach the heatsink to the motherboard. When the four screws are attached, tighten them one by one in a the same diagonal sequence to completely secure the heatsink.



---

The heatsink screws are T20 models. A torque value of  $16.1 \pm 1.2$  kgf-cm ( $14.0 \pm 1.0$  lbf-in) is recommended.

---

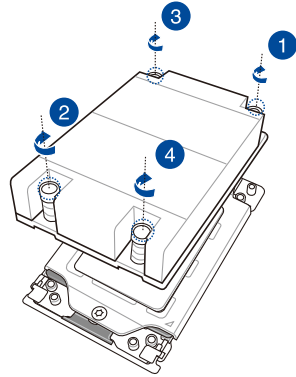

- Reinstall the air duct. For more information, see the section **Air Duct**.

## 2.3 System memory

### 2.3.1 Overview

The motherboard comes with eight (8) Double Data Rate 4 (DDR4) Dual Inline Memory Modules (DIMM) sockets.

The figure illustrates the location of the DDR4 DIMM sockets:

**KRPG-U8 288-pin DDR4 DIMM sockets**

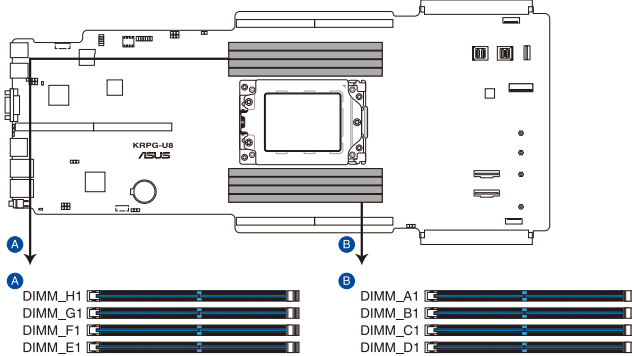

### 2.3.2 Memory Configurations

You may install 16 GB, 32 GB, 64 GB, 128 GB, 256 GB DDR4 RDIMMs into the DIMM sockets using the memory configurations in this section.



- 6 DIMM configuration is not recommended for AMD EPYC™ 7002 Series processors.
- When mixing 2DPC and 1DPC, ensure that each channel's total DIMM size should be equal. The DIMM size of 2DPC should equal to that of 1DPC, for example, if 2DPC is using a 32GB memory module (32GB \* 2), then a 64GB memory module should be installed for 1DPC.
- All memory modules for 2DPC should be the same.
- Always install DIMMs with the same CAS latency. For optimum compatibility, it is recommended that you obtain memory modules from the same vendor.

1 CPU Configuration	A1	B1	C1	D1	E1	F1	G1	H1
1 DIMM			•					
2 DIMMs			•	•				
4 DIMMs			•	•			•	•
8 DIMMs	•	•	•	•	•	•	•	•

### 2.3.3 Installing a DIMM on a single clip DIMM socket

1. Press the retaining clip outward to unlock a DIMM socket.
2. Align a DIMM on the socket such that the notch on the DIMM matches the DIMM slot key on the socket.

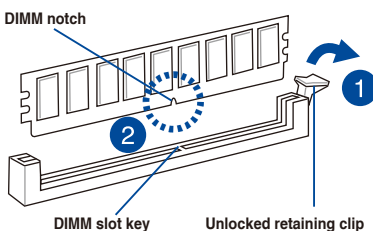

A DIMM is keyed with a notch so that it fits in only one direction. DO NOT force a DIMM into a socket in the wrong direction to avoid damaging the DIMM.

3. Hold the DIMM on both ends, then insert the DIMM vertically into the socket. Apply force to both ends of the DIMM simultaneously until the retaining clip snaps back into place, and the DIMM cannot be pushed in any further to ensure proper sitting of the DIMM.

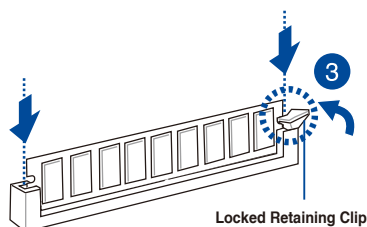

Always insert the DIMM into the socket VERTICALLY to prevent damage to the DIMM notch.



- To install two or more DIMMs, refer to the user guide bundled in the motherboard package.
- Refer to [www.asus.com](http://www.asus.com) for vendor lists of the memory modules.

### Removing a DIMM from a single clip DIMM socket

1. Press the retaining clip outward to unlock the DIMM.
2. Remove the DIMM from the socket.

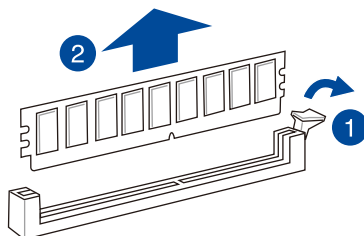

Support the DIMM lightly with your fingers when pressing the retaining clips. The DIMM might get damaged when it flips out with extra force.



## 2.4 Hard disk drives

The system supports 3.5-inch and 2.5-inch SATA/SAS hard disk drives, or U.2 drives.

### 2.4.1 Installing the 3.5-inch SATA HDD/SAS HDD

1. Press the spring lock.
2. Pull the tray lever outwards to remove the drive tray.

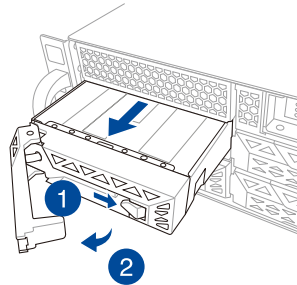

3. Prepare the SATA/SAS HDD then place the 3.5" storage device into the tray until it clicks into place.

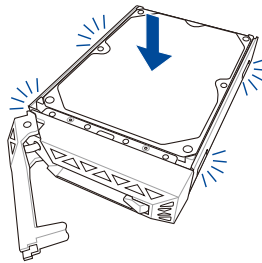

4. Push the drive tray and HDD assembly all the way into the depth of the bay until the tray lever and spring lock clicks and secures the drive tray in place.

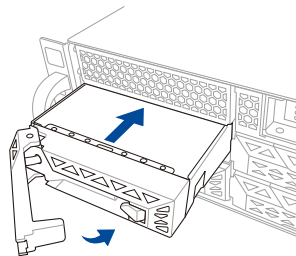

- When installed, the SATA/SAS connector on the drive connects to the SATA/SAS interface on the backplane.
- The drive tray is correctly placed when its front edge aligns with the bay edge.

5. Repeat steps 1 to 4 to install the other SATA/SAS HDDs.

## 2.4.2 Installing the 2.5-inch SSD/SATA HDD/SAS HDD/NVMe

The NVMe drives may be installed in storage device bays 5, 6, 7, and 8 as shown in the illustration below:



- The default storage device bays to install NVMe drives are storage device bays 7 and 8.
- Support for NVMe drives for storage device bays 5 and 6 is optional, please refer to the **U.2 drives (optional)** section before installing a NVMe drive to storage device bays 5 and 6.

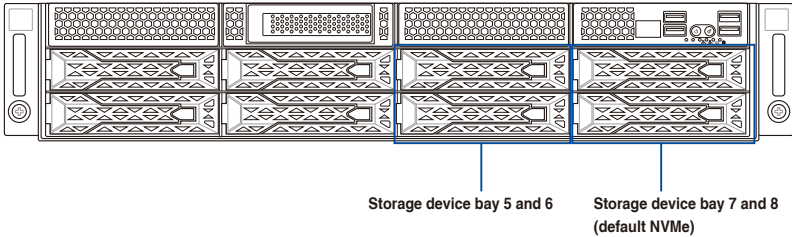

1. Remove the drive tray.



Refer to the **Installing the 3.5-inch SATA HDD/SAS HDD** section for the steps on removing the drive tray.

2. Prepare the SSD/SATA HDD/SAS HDD/NVMe and the bundled set of screws.
3. Place the SSD/SATA HDD/SAS HDD/NVMe into the tray then secure it with four screws (B).



Ensure to take note of the tool-less notch as it may interfere when trying to align the screw holes. Press the SSD/SATA HDD/SAS HDD/NVMe down on the notch if you are experiencing issues trying to align the screw holes.

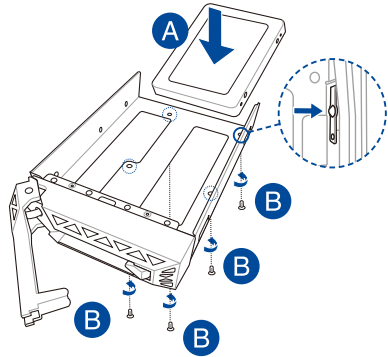

4. Replace the drive tray.



Refer to the **Installing the 3.5-inch SATA HDD/SAS HDD** section for the steps on replacing the drive tray.

5. Repeat steps 1 to 4 to install additional SSD/SATA HDD/SAS HDD/NVMe.

## 2.5 Expansion slots



Ensure to unplug the power cord before adding or removing expansion cards. Failure to do so may cause you physical injury and damage motherboard components.

### 2.5.1 The PCI Express riser card

The onboard PCI Express slot on the motherboard comes pre-installed with a riser card that supports two x16 slot (x16 Gen4 link) for installing PCI-E x16 low profile cards.

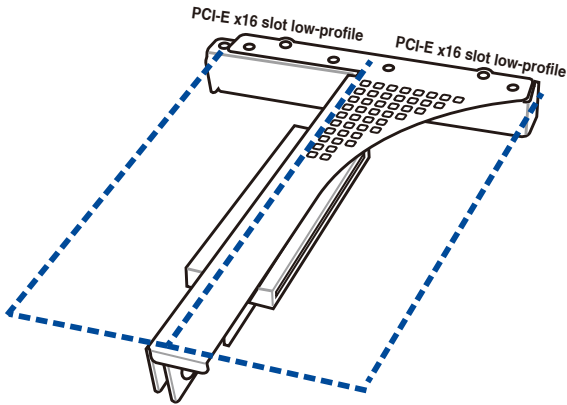

To install PCI-E expansion cards to the riser card:

1. Remove the two (2) screws that secure the riser card to the chassis.
2. Firmly hold the riser card then pull it up to detach it from the PCI Express x32 slot on the motherboard.

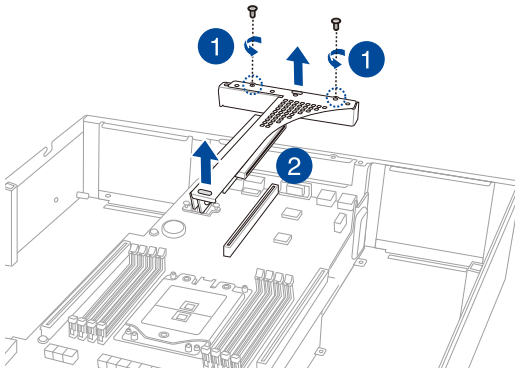

3. Remove the two (2) screws from the metal brackets on the riser card (A), then remove the metal brackets from the riser card (B).

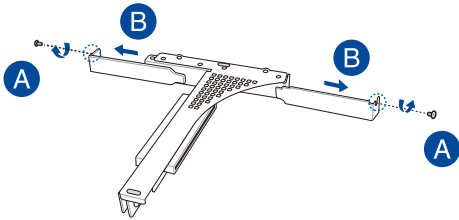

4. Prepare the expansion cards.



Before installing an expansion card, read the documentation that came with it and ensure to make the necessary hardware settings.

5. Align and insert the golden finger connectors of the expansion cards to the PCI-E slot connectors on the riser card as shown.
6. Secure the expansion cards with the screws removed earlier.

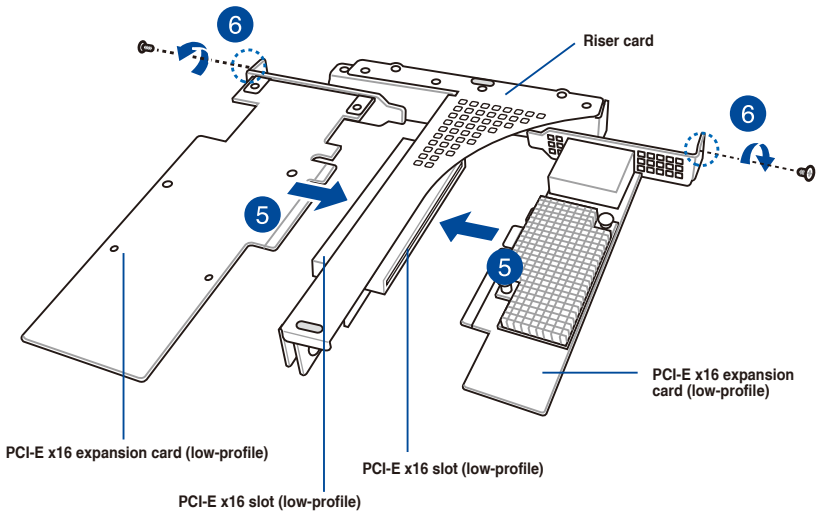

7. Align and insert the riser card and expansion card assembly into the PCI-E slot on the motherboard.



---

The expansion card fits in one orientation only. If it does not fit, try reversing it.

---

8. Secure the riser card with the two (2) screws that you removed earlier in step 1.

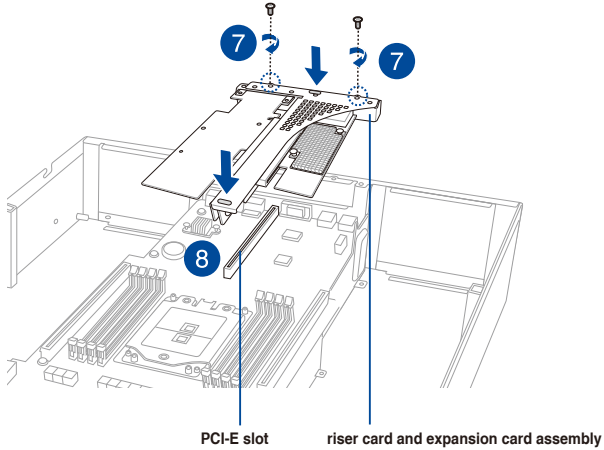

## 2.5.2 Installing an ASUS PIKE II card

You may install an ASUS PIKE II card to the internal SAS/HBA/Storage bracket located in the front of the system.

1. Remove the two (2) default slimline SAS cables from the internal SAS/HBA/Storage bracket.

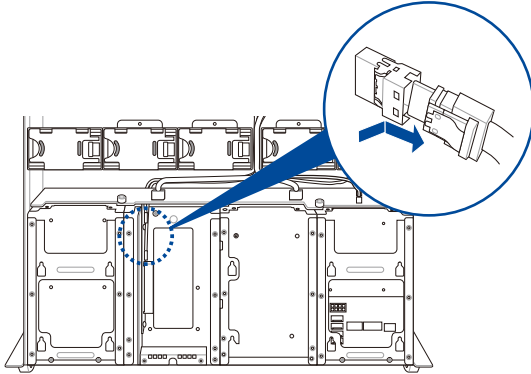

2. Remove the screw from the bracket (A), then push the internal SAS/HBA/Storage bracket towards the rear to remove the internal SAS/HBA/Storage bracket (B).

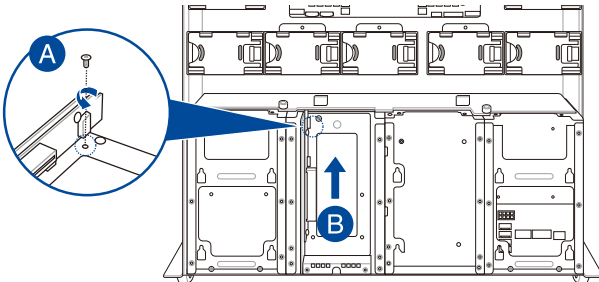

3. Remove the screw from the metal bracket (A), then remove the metal bracket.
4. Prepare the ASUS PIKE II card.

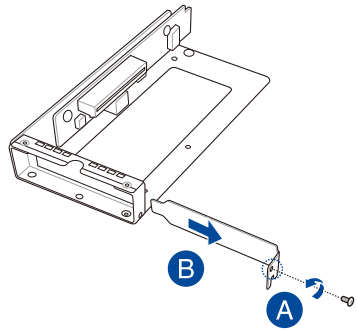

5. Remove the two screws on the ASUS PIKE II card (A), then remove the card bracket (B).

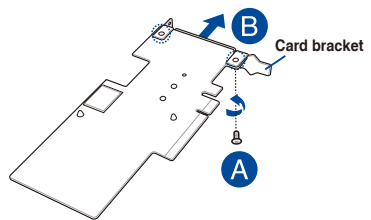

6. Secure the ASUS PIKE II card and the metal cover (internal SAS/HBA/Storage bracket) with the two screws.

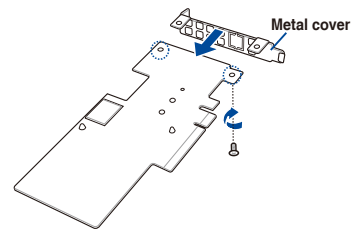

7. Insert the ASUS PIKE II card into the internal SAS/HBA/Storage bracket, then secure it with a screw.

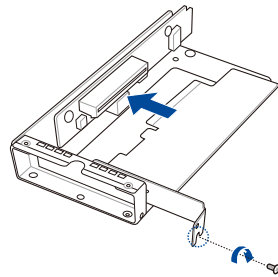

8. Connect the two (2) slimline SAS cables from the internal SAS/HBA/Storage bracket previously earlier.
9. Install the internal SAS/HBA/Storage bracket and secure it with the screw removed earlier.

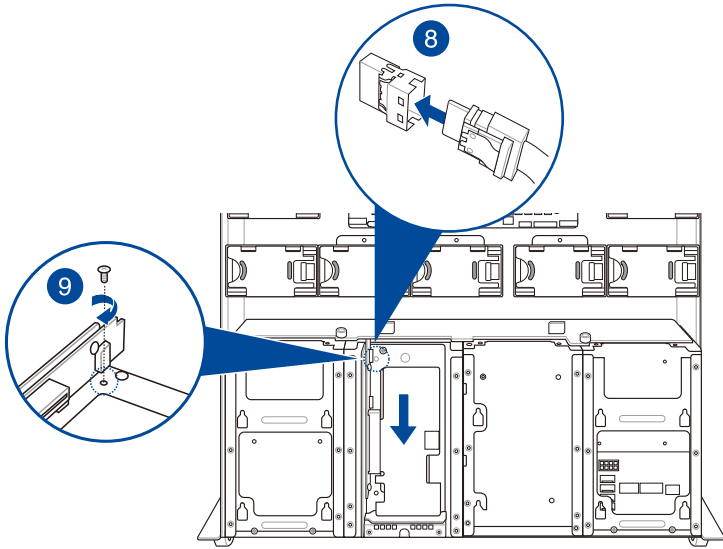

10. Remove the three (3) cables on the Cache Vault Power Module clip holder (A), then release the two (2) screws on the Cache Vault Power Module clip holder (B).

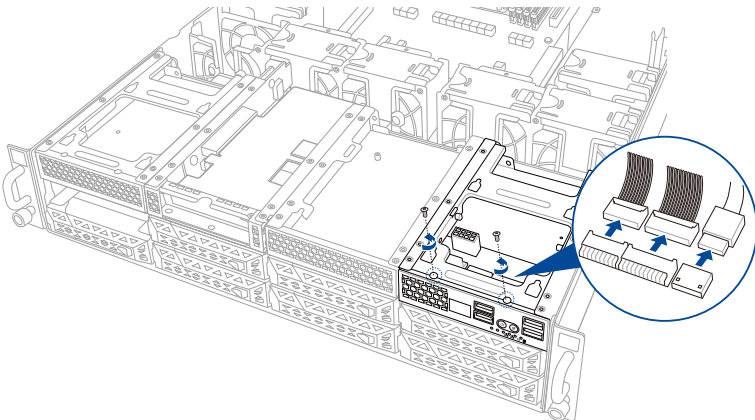



11. From the back of the Cache Vault Power Module clip holder, push the Cache Vault Power Module clip holder out of the server system.

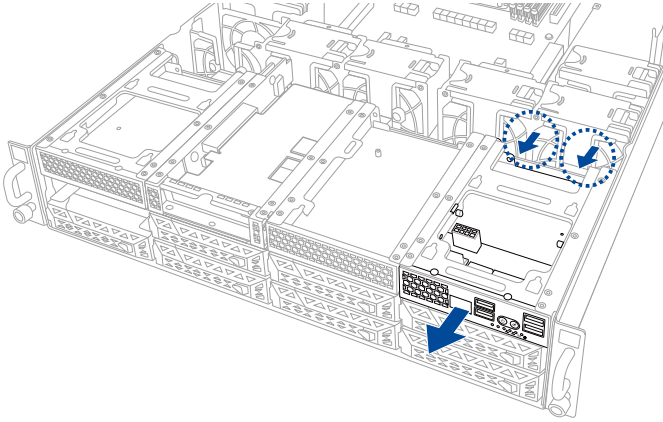

12. Align the three screw holes on the Cache Vault Power Module clip to the three screw holes on the Cache Vault Power Module clip holder, then secure the clip with the bundled three (3) screws and three (3) bundled nuts.

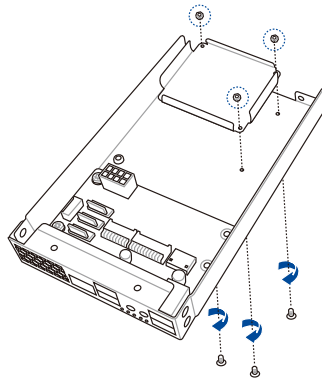

13. Align and install the Cache Vault Power Module into the Cache Vault Power Module clip.

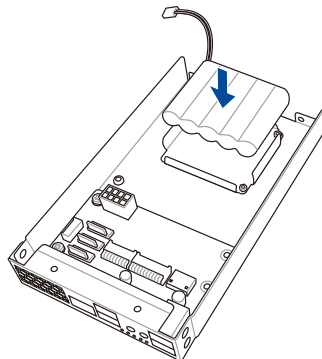

14. Insert the Cache Vault Power Module clip holder into the server system (A), then connect the bundled extension cable to the cable from the Cache Vault Power Module (B) and cable from the Cache Vault Flash Module (C).

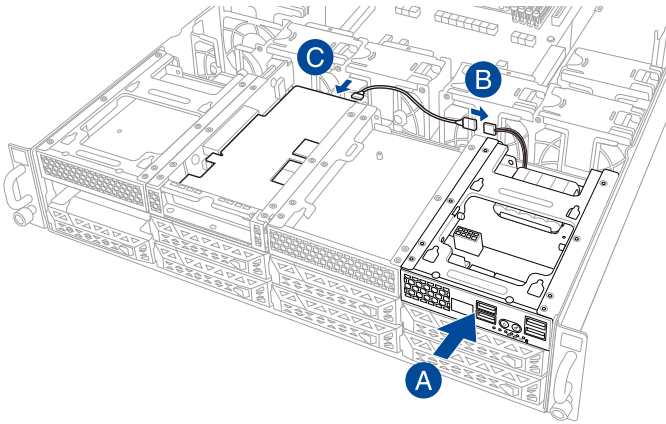

15. Reconnect the three (3) cables to the Cache Vault Power Module clip holder, ensure that the cables are not placed on top of the Cache Vault Power Module.

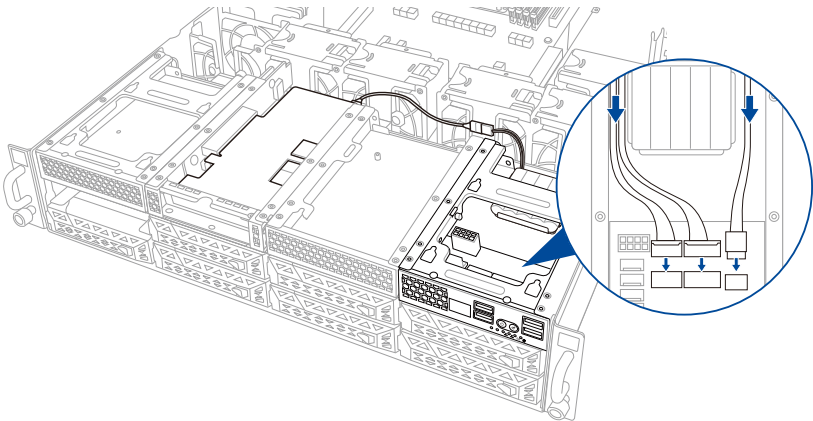

16. Secure the Cache Vault Power Module clip holder with the two (2) screws that you removed earlier in step 10.

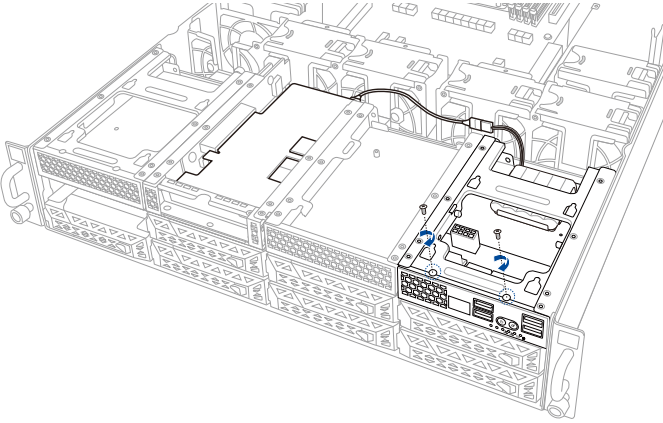

### 2.5.3 Reconnecting the cable to the M.2 expansion board (only for SKU-3)

You may reconnect the cables to enable the M.2 expansion board located in the front of the system.



The cables are connected by default if your system package comes with the M.2 expansion board pre-installed.

1. (optional) Remove the two (2) slimline SAS cables from the internal riser board for PCIe slot, if your system comes with the slimline SAS cables connected.

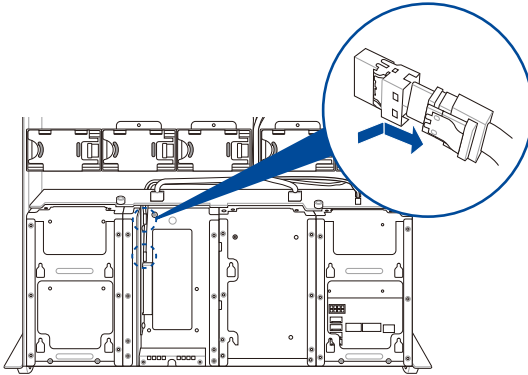

2. Connect the two (2) slimline SAS cables removed from the internal riser board for PCIe slot to your M.2 expansion board.

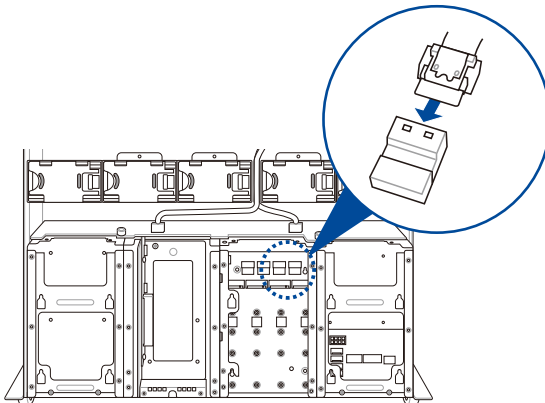

3. Connect the black 4-pin power connector to the 4-pin power connector on the M.2 expansion board.

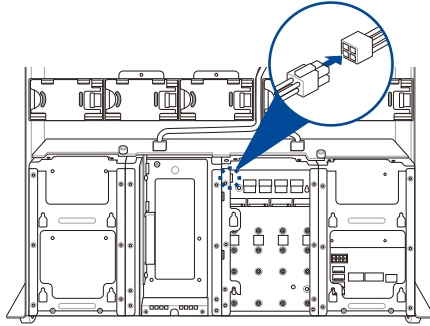

## 2.5.4 Installing an M.2 (NGFF) card

You may install an M.2 card (supports up to 22110) to the onboard M.2 (NGFF) slot on the motherboard.

1. Locate the M.2 connector (NGFF1) on the motherboard.

### KRPG-U8 M.2 (NGFF) connector

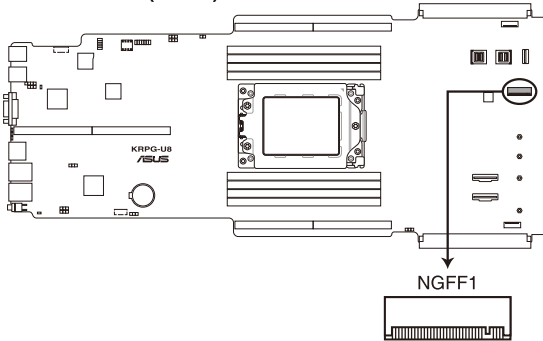

2. Remove the screw on the stand screw.
3. Prepare the M.2 card, then align and insert the M.2 card into the M.2 connector (NGFF1).
4. Secure the M.2 card with the screw you removed in step 2.

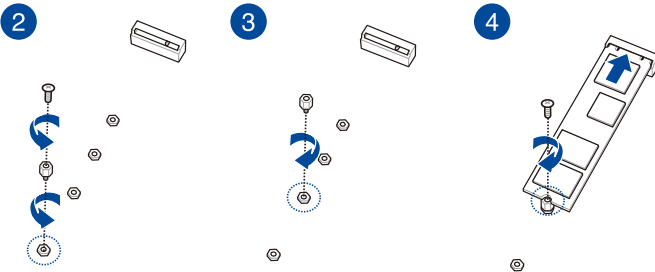

## 2.5.5 Reconnecting the cable to the OCP 3.0 slot baseboard (only for SKU-2)

You may reconnect the cables to enable the OCP3.0 slot baseboard located in the front of the system.



The cables are connected by default if your system package comes with the OCP3.0 slot baseboard pre-installed.

1. (optional) Remove the two (2) slimline SAS cables from the internal riser board for PCIe slot, if your system comes with the slimline SAS cables connected.

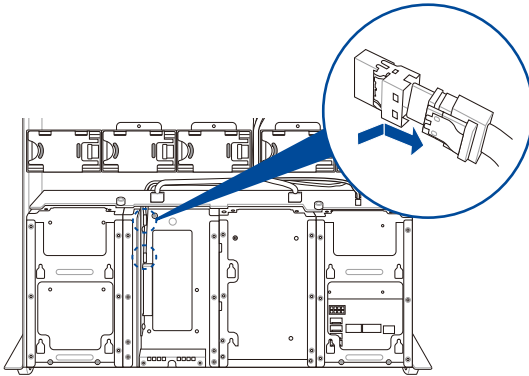

2. Connect two (2) slimline SAS cables to the two connectors to the left on your OCP3.0 slot baseboard.

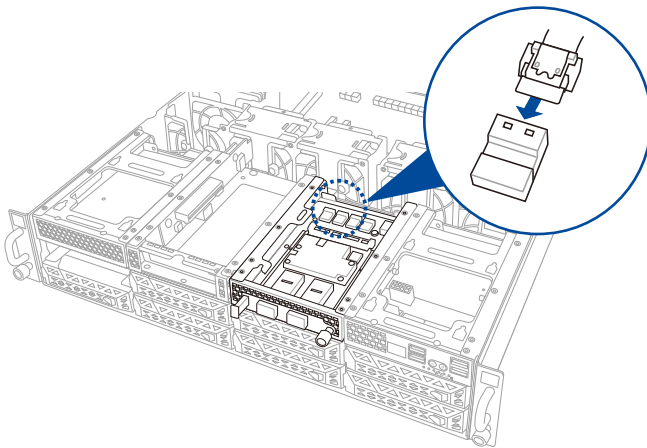

3. Connect the white 4-pin power connector to the 4-pin power connector on the OCP3.0 slot baseboard.

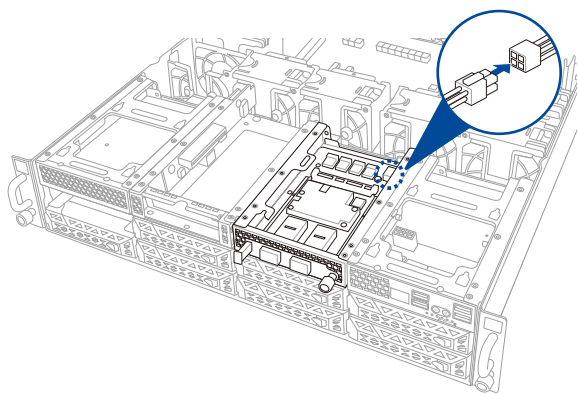



## 2.5.6 Configuring an expansion card

After installing the expansion card, configure it by adjusting the software settings.

1. Turn on the system and change the necessary BIOS settings, if any. See the **BIOS Setup** chapter for information on BIOS setup.
2. Assign an IRQ to the card. Refer to the **Standard Interrupt assignments** table for more information.
3. Install the software drivers for the expansion card.

### Standard Interrupt assignments

IRQ	Priority	Standard function
0	1	System Timer
1	2	Keyboard Controller
2	-	Programmable Interrupt
3*	11	Communications Port (COM2)
4*	12	Communications Port (COM1)
5*	13	--
6	14	Floppy Disk Controller
7*	15	--
8	3	System CMOS/Real Time Clock
9*	4	ACPI Mode when used
10*	5	IRQ Holder for PCI Steering
11*	6	IRQ Holder for PCI Steering
12*	7	PS/2 Compatible Mouse Port
13	8	Numeric Data Processor
14*	9	Primary IDE Channel
15*	10	Secondary IDE Channel

\* These IRQs are usually available for ISA or PCI devices.

## 2.6 Cable connections



- The bundled system cables are pre-connected before shipment. You do not need to disconnect these cables unless you remove the pre-installed components to install additional devices.
- If you need to remove pre-connected system cables please ensure to remove the cable organizer metal cover beforehand.
- Refer to the **Motherboard Information** chapter for information on the connectors.

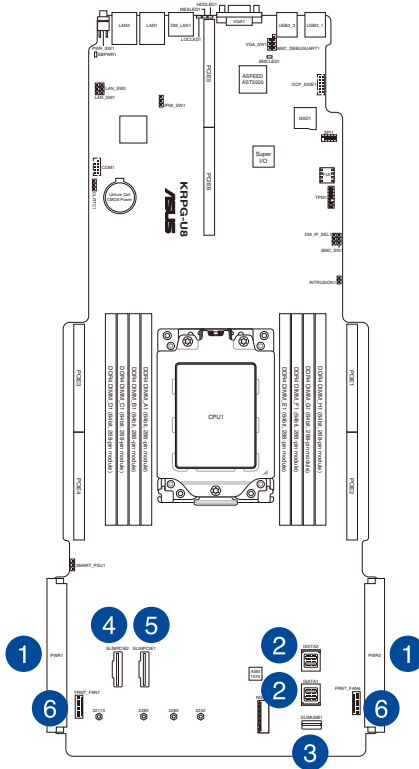

### Pre-connected system cables

1. SSI power connector (from the power distribution board to the motherboard)
2. ISATA connectors (from motherboard to SATA/SAS/U.2 backplane board)
3. Slim USB connector (from the motherboard to front I/O board)
4. SLIMPCIE2 connector (from motherboard to SATA/SAS/U.2 backplane board)
5. SLIMPCIE1 connector (from motherboard to internal riser board for PCIe slot)
6. System fan connectors (from motherboard FRNT\_FAN6, and FRNT\_FAN7 to system fans)

## 2.7 SATA/SAS backplane cabling

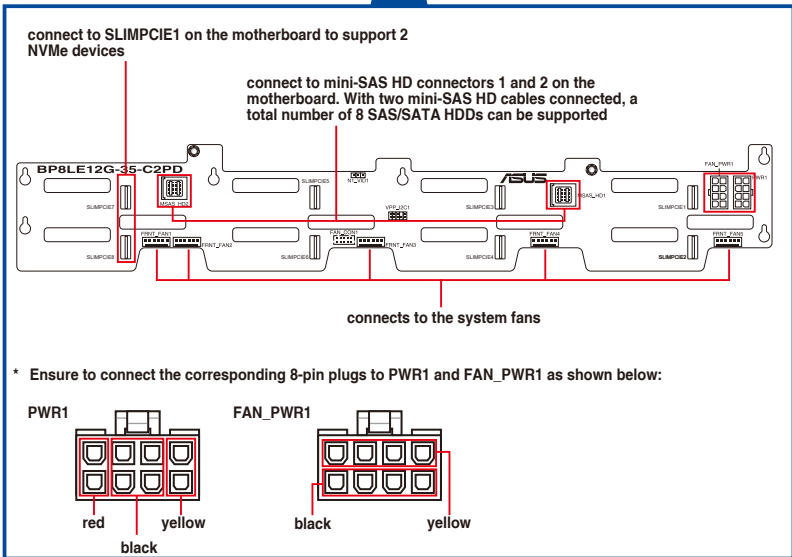
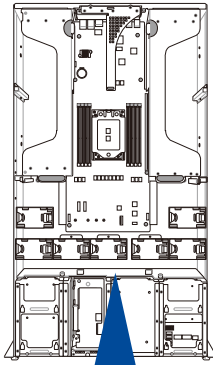

## 2.8 Removable/optional components

The following sections describe installation or removal instructions for the following removable/optional components:

1. Cable organizer metal cover
2. System fans
3. Redundant power supply units
4. U.2 drives
5. GPU cards



---

Ensure that the system is turned off before removing any components.

---

### 2.8.1 Cable organizer metal cover

When you need to organize the cables connecting from the rear to the front of the system, you may need to remove the cable organizer metal cover beforehand.

1. Locate the cable organizer metal cover in between the system fans.

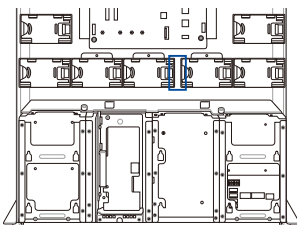

2. Pull the cable organizer metal cover upwards to remove it from the system.

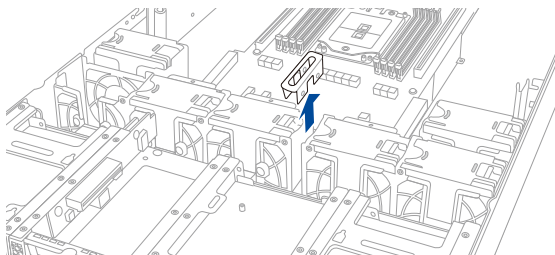

3. Once you have finished organizing the cables, ensure to replace the cable organizer metal cover.

## 2.8.2 System fans

To uninstall the system fans:

1. Hold the system fan by the notches (A), then press the latch inwards (B) to release the system fan from the fan cage.
2. Lift the fan then set it aside.
3. Repeat steps 1 to 2 to uninstall the other system fans.

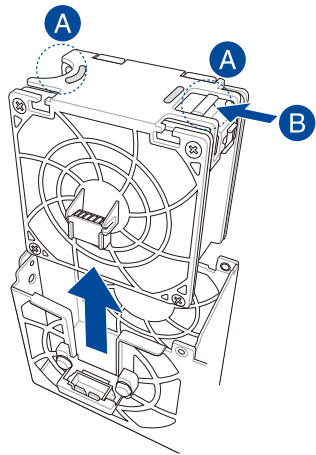

To reinstall the system fans:

1. Insert the fan into the fan cage. Ensure the fan connector is seated firmly within the cable holder.

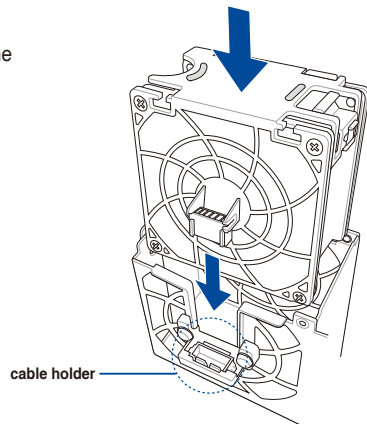

## 2.8.3 Redundant power supply units



We recommend that you use both of your hands in performing the following steps.

To replace a power supply unit (PSU):

1. Lift up the PSU lever.
2. Hold the PSU lever, press the PSU latch (A) then carefully pull the PSU out of the system chassis (B).

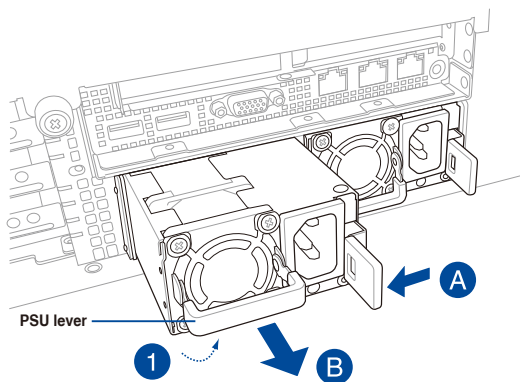

3. Prepare the replacement PSU.
4. Align and insert the replacement PSU into the empty PSU bay until it clicks in place.

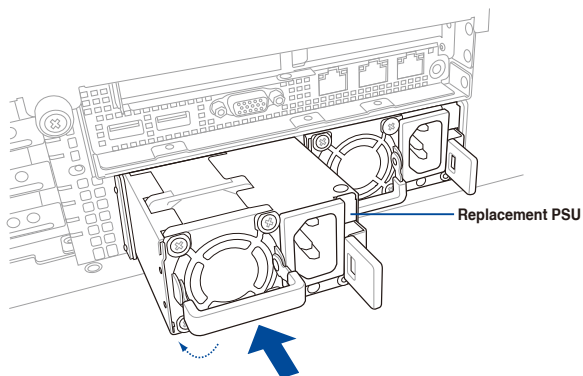



- The system automatically combines the two power supply modules as a single one. The combined output power varies with input voltages. Refer to the table below for details.

#### **1600W**

<b>Input Voltage</b>	<b>Max. Output Power (Watt) per PSU</b>
100V-127Vac, 13A, 50-60Hz	1000W
100V-127Vac, 12.9A, 47-63Hz	
200V-240Vac, 9.5A, 50-60Hz	1600W
200V-240Vac, 9.5A, 47-63Hz	

#### **2200W**

<b>Input Voltage</b>	<b>Max. Output Power (Watt) per PSU</b>
100V-127Vac, 14A, 47-63Hz	1200W
200V-240Vac, 12.6A, 47-63Hz	2200W

- To enable the hot-swap feature (redundant mode), keep the total power consumption of the system under the maximum output power of an individual power supply module.



- Always use PSUs with the same watt and power rating. Combining PSUs with different wattage (e.g. 1 x 1620 W + 1 x 2000 W) may yield unstable results and potential damage to your system.
- For a steady power input, use only the power cables that come with the server system package.

## 2.8.4 U.2 drives

Additional U.2 drives may be installed in storage device bays 5 and 6 as shown in the illustration below:

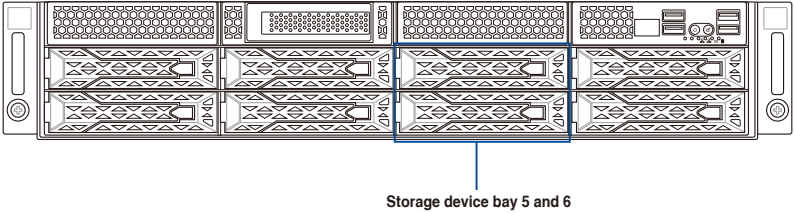

To install a U.2 drive:

1. Install the U.2 drive to storage device bay 5 or 6.



---

Refer to the **Installing the 2.5-inch SSD** section for the steps on installing a 2.5-inch drive to the HDD bay.

---

2. Remove the slimline SAS cables from the internal SAS/HBA/Storage bracket.

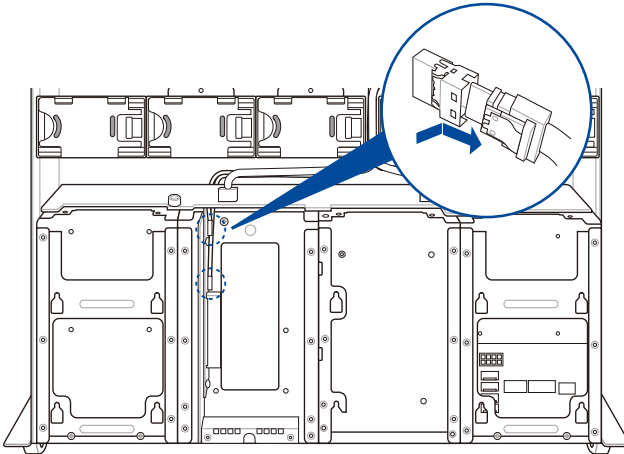



3. Connect the slimline SAS cables removed in step 2 to the SLIMPCIE5 and SLIMPCIE6 slots located on the backplane.

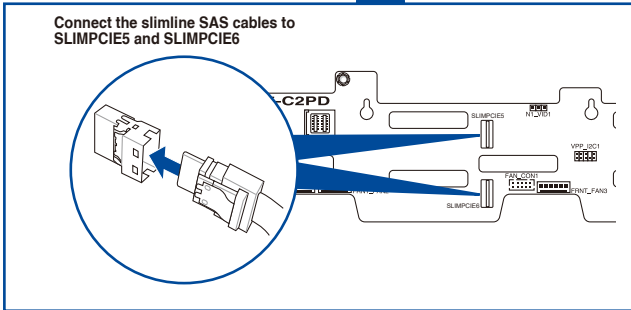
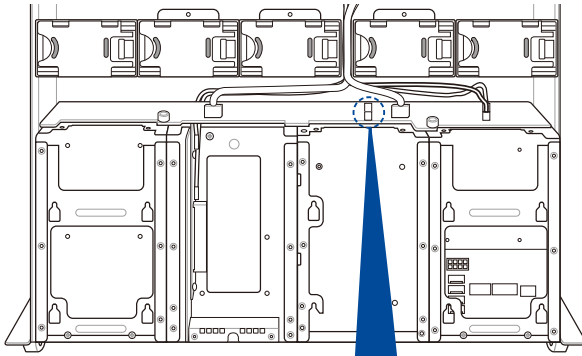

## 2.8.5 GPU cards

Follow the steps below to install a GPU card to the system.

1. Locate and remove the two screws at the rear of the chassis.

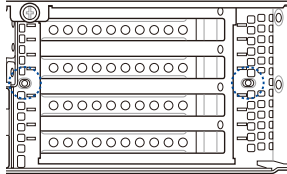

2. Locate and loosen the thumbscrew at the front of the GPU bracket.
3. Firmly hold and pull the GPU bracket upwards to detach it from the motherboard.

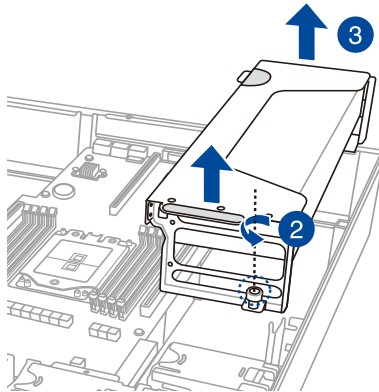

4. Prepare the appropriate GPU power cable depending on the type of GPU card.

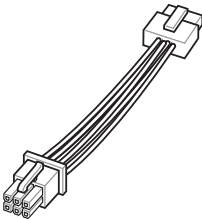

**Tesla/AMD**  
8pin to 6pin power cable

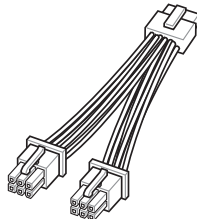

**Quadro**  
8pin to 2x6pin power cable

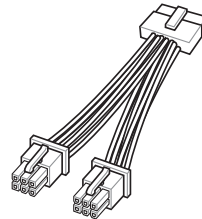

**12VHPWR**  
12+4pin to 2x6pin power cable

5. Install the air duct, if supported by the GPU card, and connect the GPU power cable.



The GPU air duct is designed and recommended for dual-slot GPU cards with a length of 10.5 inches.

#### For GPU card installation with an air duct

Pass the power cable through the air duct and connect it to the GPU card, then secure the air duct to the GPU card with two screws.

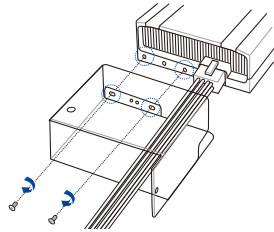

#### For GPU card installation without an air duct

Connect the power cable to the GPU.

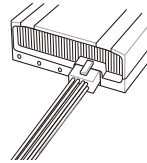

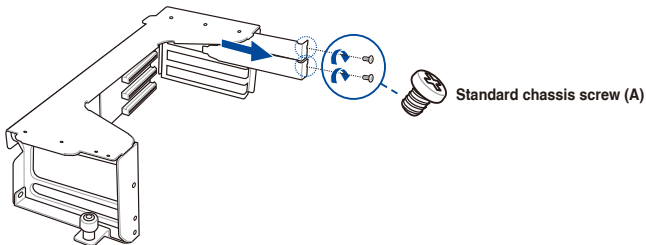

6. Place the GPU bracket on a flat and stable surface.
7. Remove the screws on the metal covers, then remove the metal covers.

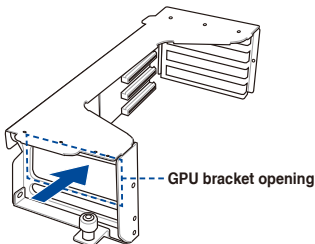

8. Insert the GPU cables into the opening on the GPU bracket.



9. Align and insert the golden fingers of the GPU card into the card slot on the bracket and ensure that it is securely seated in the slot.
10. Secure the GPU card and air duct assembly to the GPU bracket.

	Standard chassis screw (A)	#6-32 X L 4.2 OD 6mm	6.0±0.5 kgf-cm
	GPU support screw (B)	#6-32 X L 4.76 OD 8mm	6.0±0.5 kgf-cm



The GPU support screws are bundled in the accessory bag. Contact your retailer if any screws are missing.

### For GPU card installation with an air duct

Secure the GPU card to the GPU bracket with two standard chassis screws, then secure the air duct using one GPU support screw.

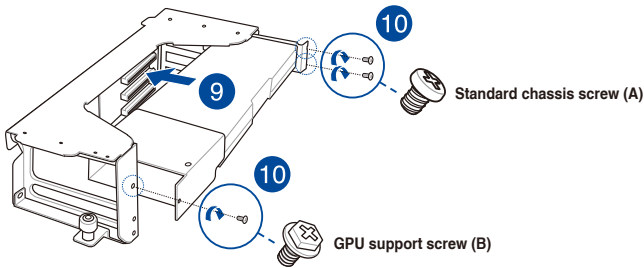

### For GPU card installation without an air duct

Secure the GPU card to the GPU bracket with one or two GPU support screws depending on the type of GPU card.

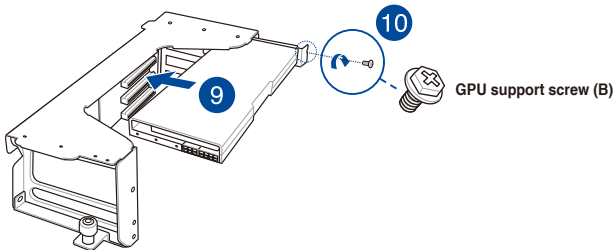

11. Repeat steps 4 to 10 if you need to install an additional GPU card to the bracket.

- Align and insert the golden fingers of the GPU bracket into the card slot on the motherboard and ensure that it is securely seated in the slot.
- Secure the thumbscrew at the front of the GPU bracket.

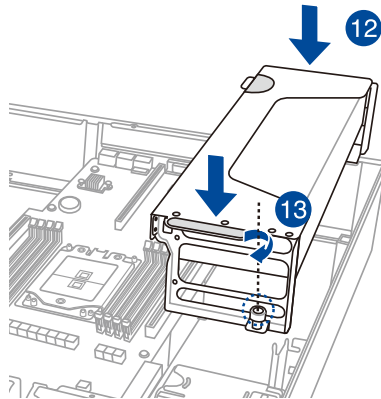

- Connect the other end of the GPU power cable to an available 6-pin power connector in front of the GPU bracket.

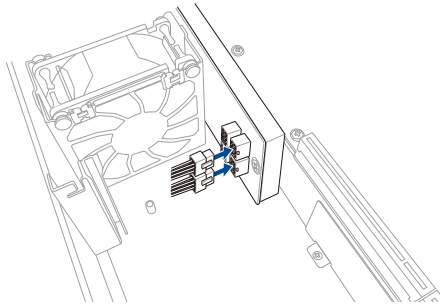

- Secure the GPU bracket to the server chassis with two screws.

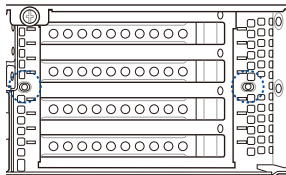

## 2.9 Rail Kit Options

This server system supports the rail kit options listed below. For more information on rail kit installation, refer to corresponding documentation on the ASUS support site or on the official product site for this server system.



- 
- We strongly recommend that at least two able-bodied persons perform the installation of the rail kit.
  - We recommend the use of an appropriate lifting tool or device, if necessary.
- 
- 1m half extension ball bearing rail kit
  - 1.2m half extension ball bearing rail kit

# Motherboard Information

# 3

This chapter gives information about the motherboard that comes with the server. This chapter includes the motherboard layout, jumper settings, and connector locations.

# 3.1 KRPG-U8 Motherboard layout

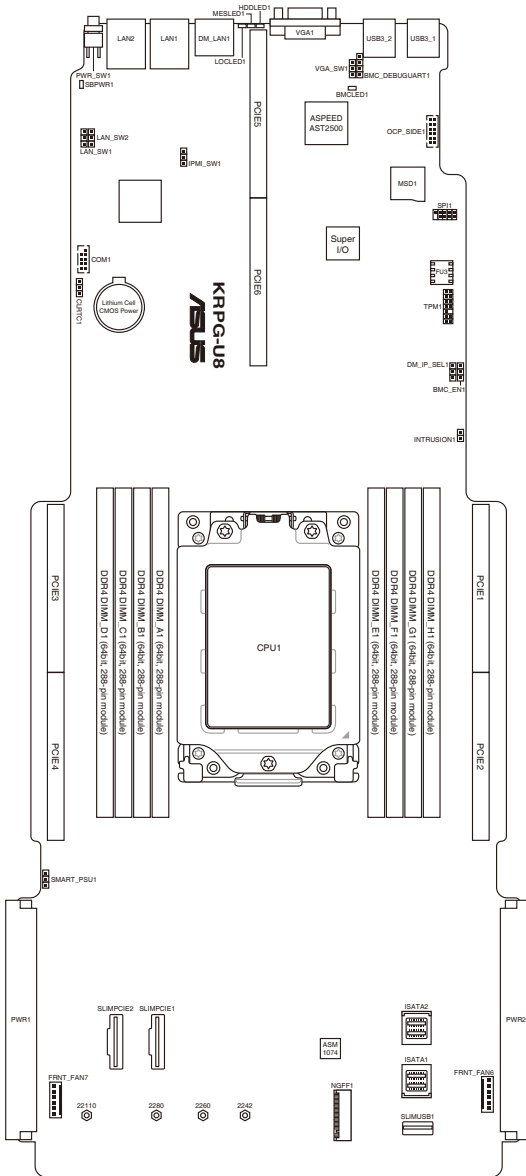



## Layout contents

Jumpers	Page
1. Clear RTC RAM (CLRTC1)	3-4
2. VGA controller setting (3-pin VGA_SW1)	3-5
3. LAN controller setting (3-pin LAN_SW1, LAN_SW2)	3-5
4. Baseboard Management Controller setting (3-pin BMC_EN1)	3-6
5. DMLAN setting (3-pin DM_IP_SEL1)	3-6
6. IPMI SW setting (3-pin IPMI_SW1)	3-7
7. Smart Ride Through jumper (3-pin SMART_PSU1)	3-7

Internal connectors	Page
1. Mini-SAS HD connector (ISATA1-2)	3-8
2. Slim PCIe connectors (SLIMPCIE1-2)	3-8
3. USB 3.2 Gen 1 connectors (SLIMUSB1)	3-9
4. Chassis Intrusion (2-pin INTRUSION1)	3-9
5. Front fan connectors (6-pin FRNT_FAN6-7)	3-10
6. Serial port connector (10-1 pin COM1)	3-11
7. TPM connector (13-1 pin TPM1)	3-11
8. M.2 (NGFF) card connector (NGFF1)	3-12
9. CRPS power connectors (PWR1-2)	3-13
10. MicroSD card slot (MSD1)	3-14
11. OCP3.0 Sideband Signal connector (10-pin OCP_SIDE1)	3-15

Onboard LEDs	Page
1. Standby Power LED (SBPWR1)	3-16
2. Baseboard Management Controller LED (BMCLED1)	3-16
3. Hard disk activity LED (HDDLED1)	3-17
4. Message LED (MESLED1)	3-17
5. Location LED (LOCLED1)	3-18

## 3.2 Jumpers

### 1. Clear RTC RAM (CLRRTC1)

This jumper allows you to clear the CMOS memory system setup parameters by erasing the CMOS Real Time Clock (RTC) RAM data. The onboard button cell battery powers the RAM data in CMOS, which include system setup information such as system passwords.

To erase the RTC RAM:

1. Turn OFF the computer and unplug the power cord.
2. Move the jumper cap from pins 1–2 (default) to pins 2–3. Keep the cap on pins 2–3 for about 5–10 seconds, then move the cap back to pins 1–2.
3. Plug the power cord and turn ON the computer.
4. Hold down the <Del> key during the boot process and enter BIOS setup to re-enter data.



Except when clearing the RTC RAM, never remove the cap on CLRRTC jumper default position. Removing the cap will cause system boot failure!



If the steps above do not help, remove the onboard battery and move the jumper again to clear the CMOS RTC RAM data. After the CMOS clearance, reinstall the battery.

### KRPG-U8 Clear RTC RAM

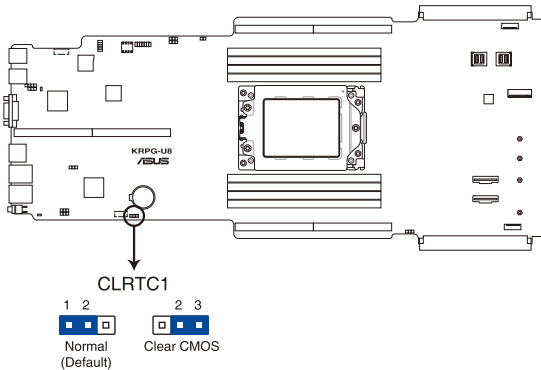

## 2. VGA controller setting (3-pin VGA\_SW1)

This jumper allows you to enable or disable the onboard VGA controller. Set to pins 1–2 to activate the VGA feature.

### KRPG-U8 VGA controller setting

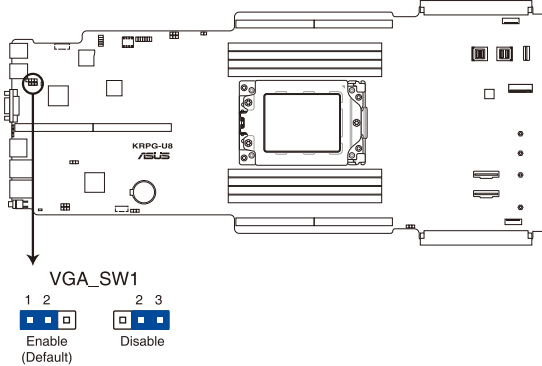

## 3. LAN controller setting (3-pin LAN\_SW1, LAN\_SW2)

These jumpers allow you to enable or disable the onboard Intel® I350-AM2 Gigabit LAN 1/2 controllers. Set to pins 1-2 to activate the Gigabit LAN feature.

### KRPG-U8 LAN setting

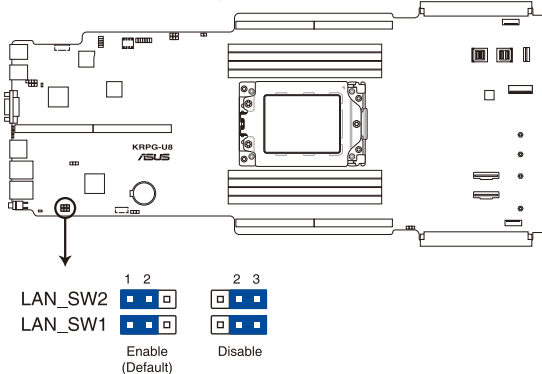

#### 4. Baseboard Management Controller setting (3-pin BMC\_EN1)

This jumper allows you to enable (default) or disable on-board BMC. Ensure to set this BMC jumper to enabled to avoid system fan control and hardware monitor error.

##### KRPG-U8 BMC setting

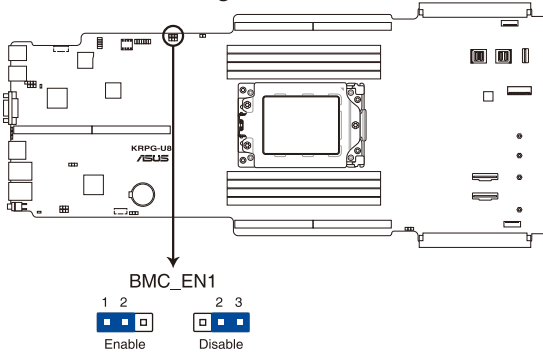

#### 5. DMLAN setting (3-pin DM\_IP\_SEL1)

This jumper allows you to select the DMLAN setting. Set to pins 2-3 to force the DMLAN IP to static mode (IP=10.10.10.10, submask=255.255.255.0).

##### KRPG-U8 DM\_IP\_SEL1 setting

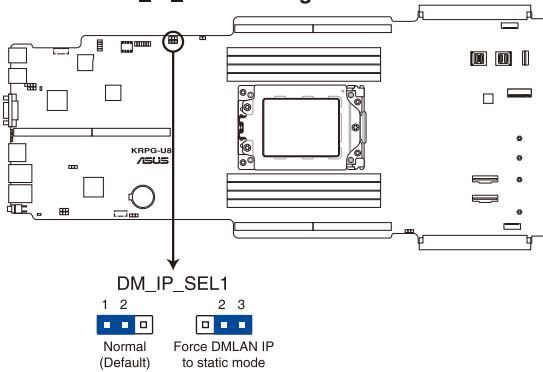

## 6. IPMI SW setting (3-pin IPMI\_SW1)

This jumper allows you to select which protocol in the GPU sensor to function.

### KRPG-U8 IPMI\_SW1 setting

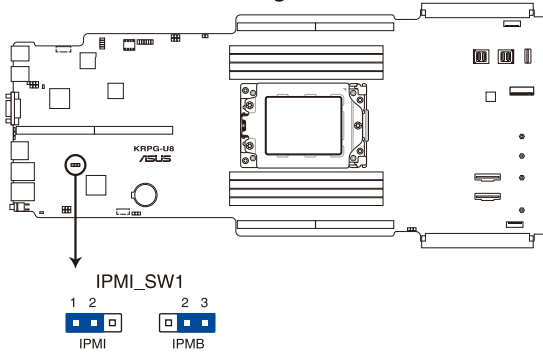

## 7. Smart Ride Through jumper (3-pin SMART\_PSU1)

Set to pins 1-2 to enable the Smart Ride Through (SmaRT) feature to allow uninterrupted operation of the system during an AC loss event.

### KRPG-U8 Smart Ride Through setting

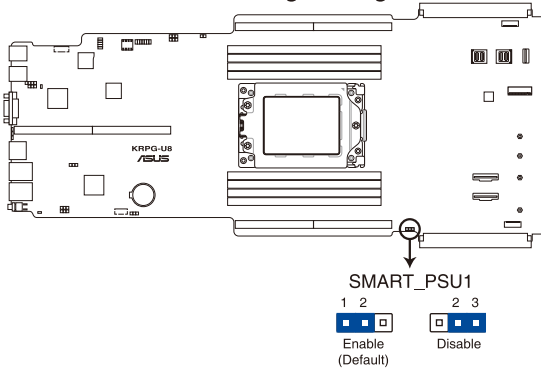

### 3.3 Internal connectors

#### 1. Mini-SAS HD connector (ISATA1-2)

This motherboard comes with mini Serial Attached SCSI (SAS) HD connectors, the storage technology that supports Serial ATA. Each connector supports up to four devices.

##### KRPG-U8 Mini-SAS HD connectors

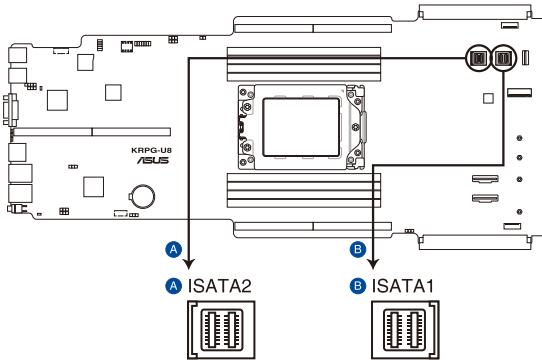

#### 2. Slim PCIe connectors (SLIMPCIE1-2)

Connects the PCIe signal to the front riser card or NVMe port on the backplane.

##### KRPG-U8 SLIMPCIE connectors

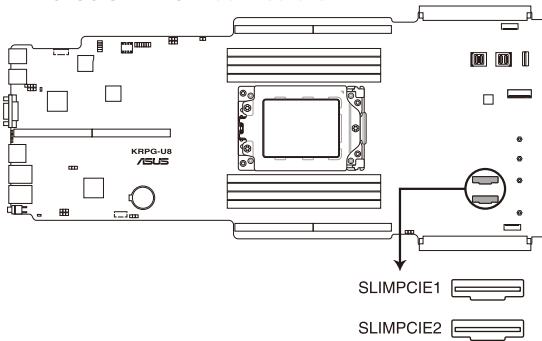

### 3. USB 3.2 Gen 1 connectors (SLIMUSB1)

Connect a compatible USB module cable to the SLIMUSB1 connector, and then install the module to a slot opening at the back or front of the system chassis. You can enjoy all the benefits of USB 3.2 Gen 1 including faster data transfer speeds of up to 5 Gbps, faster charging time for USB-chargeable devices, optimized power efficiency, and backward compatibility with USB 2.0. (SLIMUSB1 connector is used for the front USB panel by default).

#### KRPG-U8 SLIMUSB connector

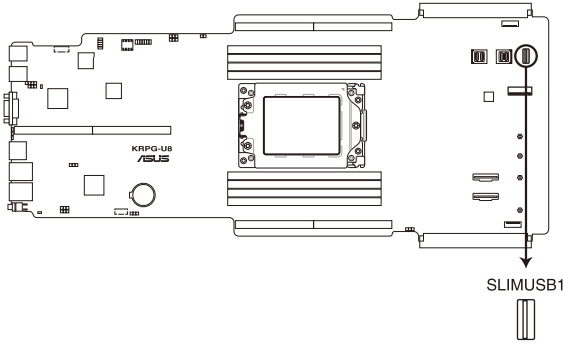

### 4. Chassis Intrusion (2-pin INTRUSION1)

These leads are for the intrusion detection feature for chassis with intrusion sensor or microswitch. When you remove any chassis component, the sensor triggers and sends a high level signal to these leads to record a chassis intrusion event. The default setting is to short the CHASSIS# and the GND pin by a jumper cap to disable the function.

#### KRPG-U8 Chassis Intrusion connector

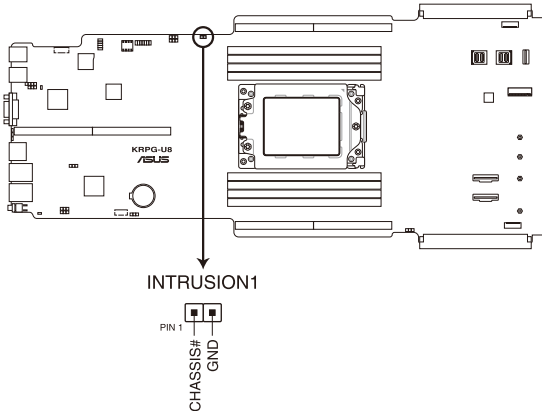

**5. Front fan connectors (6-pin FRNT\_FAN6-7)**

The fan connectors support cooling fans of 3.30 A – 3.95 A (47.4 W max.) Connect the fan cables to the fan connectors on the motherboard, ensuring that the black wire of each cable matches the ground pin of the connector.



- DO NOT forget to connect the fan cables to the fan connectors. Insufficient air flow inside the system may damage the motherboard components.
- These are not jumpers! DO NOT place jumper caps on the fan connectors!



All fans feature the ASUS Smart Fan technology.

**KRPG-U8 FAN connectors**

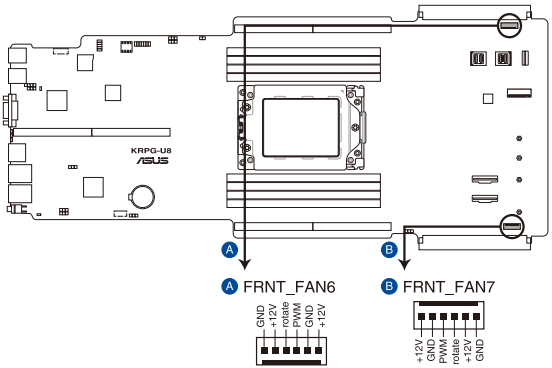



## 6. Serial port connector (10-1 pin COM1)

This connector is for the serial COM port. Connect the serial port module cable to one of these connectors, then install the module to a slot opening at the back of the system chassis.

### KRPG-U8 Serial port connector

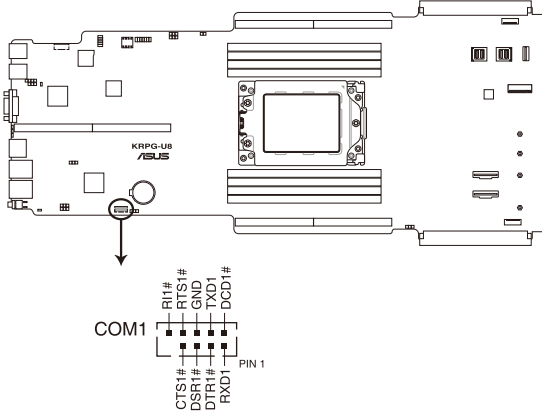

## 7. TPM connector (14-1 pin TPM1)

This connector supports a Trusted Platform Module (TPM) system, which can securely store keys, digital certificates, passwords, and data. A TPM system also helps enhance network security, protects digital identities, and ensures platform integrity.

### KRPG-U8 Trusted Platform Module connector

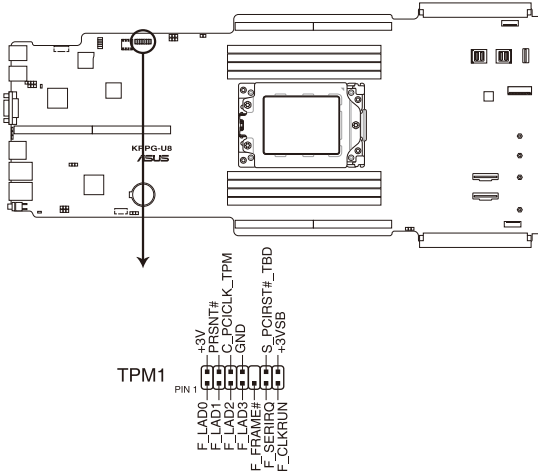

**8. M.2 (NGFF) card slot (NGFF1)**

This slot allows you to install M.2 devices.

**KRPG-U8 M.2 (NGFF) connector**

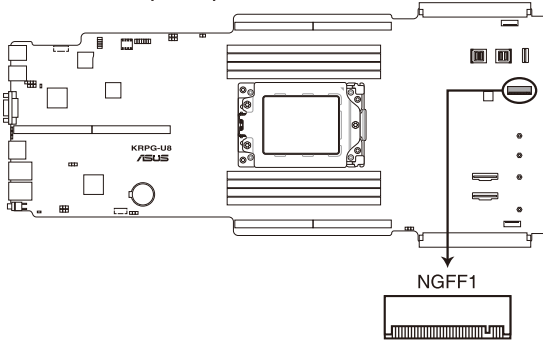

---

This connector supports type 2242 / 2260 / 2280 / 22110 devices on PCIe interface.

---



---

The M.2 (NGFF) device is purchased separately

---

## 9. CRPS power connectors (PWR1-2)

These connectors are for CRPS power supply plugs. The power supply plugs are designed to fit these connectors in only one orientation. Find the proper orientation and push down firmly until the connectors completely fit.



- Use of a PSU with a higher power output is recommended when configuring a system with more power-consuming devices. The system may become unstable or may not boot up if the power is inadequate.
- Ensure that your power supply unit (PSU) can provide at least the minimum power required by your system.

### KRPG-U8 ATX power connectors

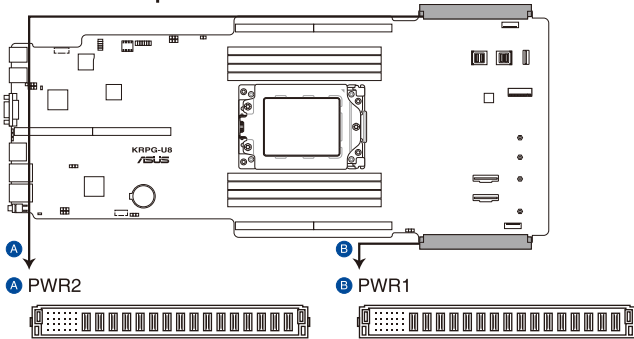

## 10. MicroSD card slot (MSD1)

The microSD card slot allows you to install a microSD memory card v2.00 (SDHC) / v3.00 (SDXC) to log BMC events.

### KRPG-U8 Micro SD card slot

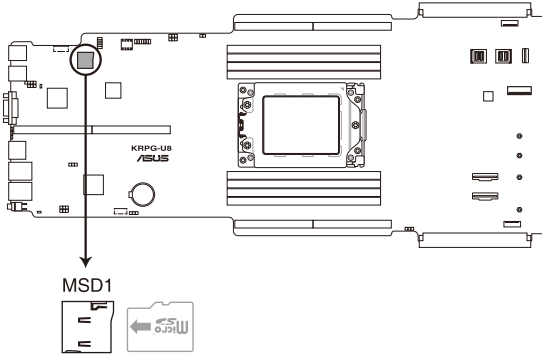

---

Disconnect all power (including redundant PSUs) from the existing system before you add or remove a memory card, then reboot the system to access the memory card.

---



---

Some memory cards may not be compatible with your motherboard. Ensure that you use only compatible memory cards to prevent loss of data, damage to your device, or memory card, or both.

---

### 11. OCP3.0 Sideband Signal connector (12-pin OCP\_SIDE1)

This connector is for OCP3.0 sideband signal and allows you to connect an external OCP3.0 card to support additional features such as power brake and scan chain.

#### KRPG-U8 OCP\_SIDE connector

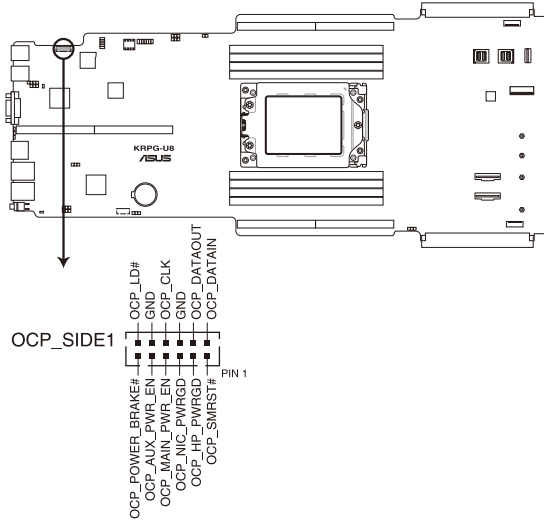

# 3.4 Onboard LEDs

## 1. Standby Power LED (SBPWR1)

The motherboard comes with a standby power LED. The green LED lights up to indicate that the system is ON, in sleep mode, or in soft-off mode. This is a reminder that you should shut down the system and unplug the power cable before removing or plugging in any motherboard component. The illustration below shows the location of the onboard LED.

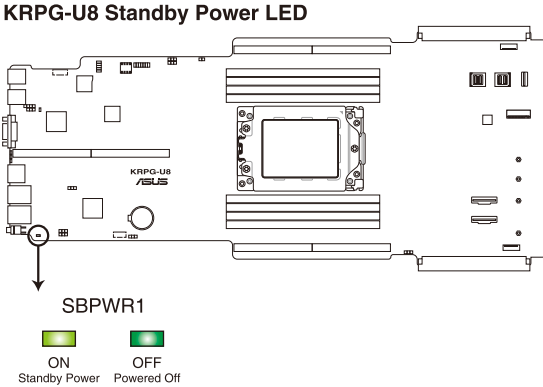

## 2. Baseboard Management Controller LED (BMCLED1)

The BMC LED lights up to indicate that the on-board BMC is functional.

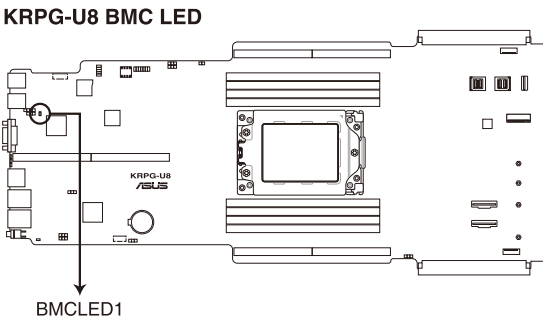

**3. Hard disk activity LED (HDDLED1)**

This LED is for the storage devices connected to the onboard SATA, or SATA/SAS add-on card. The read or write activities of any device connected to the onboard SATA, or SATA/SAS add-on card causes the rear panel LED to light up.

**KRPG-U8 Storage device activity LED**

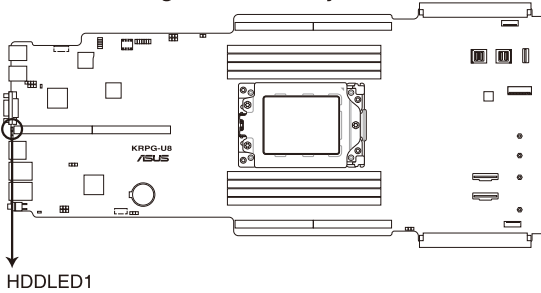

**4. Message LED (MESLED1)**

This onboard LED lights up to red when there is temperature warning or a BMC event log is generated.

**KRPG-U8 MESLED**

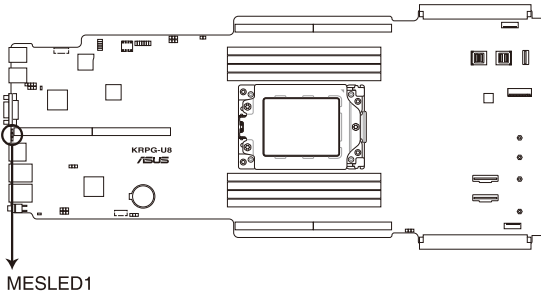

**5. Location LED (LOCLED1)**

This onboard LED lights up when the Location button on the server is pressed or when triggered by a system management software. The Location LED helps visually locate and quickly identify the server in error on a server rack.

**KRPG-U8 Location LED**

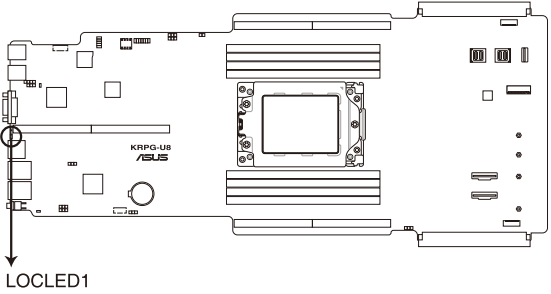



# **BIOS Setup**

# 4

This chapter tells how to change system settings through the BIOS Setup menus and describes the BIOS parameters.

## 4.1 Managing and updating your BIOS

The following utilities allow you to manage and update the motherboard Basic Input/Output System (BIOS) setup:

1. **ASUS CrashFree BIOS 3**

To recover the BIOS using a bootable USB flash disk drive when the BIOS file fails or gets corrupted.

2. **ASUS EzFlash**

Updates the BIOS using a USB flash disk.

3. **BUPDATER**

Updates the BIOS in DOS mode using a bootable USB flash disk drive.

Refer to the corresponding sections for details on these utilities.



---

Save a copy of the original motherboard BIOS file to a bootable USB flash disk drive in case you need to restore the BIOS in the future. Copy the original motherboard BIOS using the BUPDATER utility.

---

### 4.1.1 ASUS CrashFree BIOS 3 utility

The ASUS CrashFree BIOS 3 is an auto recovery tool that allows you to restore the BIOS file when it fails or gets corrupted during the updating process. You can update a corrupted BIOS file using a USB flash drive that contains the updated BIOS file.



---

Prepare a USB flash drive containing the updated motherboard BIOS before using this utility.

---

### Recovering the BIOS from a USB flash drive

To recover the BIOS from a USB flash drive:

1. Insert the USB flash drive with the original or updated BIOS file to one USB port on the system.
2. The utility will automatically recover the BIOS. It resets the system when the BIOS recovery finished.



---

**DO NOT** shut down or reset the system while recovering the BIOS! Doing so would cause system boot failure!

---



---

The recovered BIOS may not be the latest BIOS version for this motherboard. Visit the ASUS website at [www.asus.com](http://www.asus.com) to download the latest BIOS file.

---

## 4.1.2 ASUS EZ Flash Utility

The ASUS EZ Flash Utility feature allows you to update the BIOS without having to use a DOS-based utility.



Before you start using this utility, download the latest BIOS from the ASUS website at [www.asus.com](http://www.asus.com).

To update the BIOS using EZ Flash Utility:

1. Insert the USB flash disk that contains the latest BIOS file into the USB port.
2. Enter the BIOS setup program. Go to the **Tool** menu then select **Start ASUS EZ Flash**. Press <Enter>.

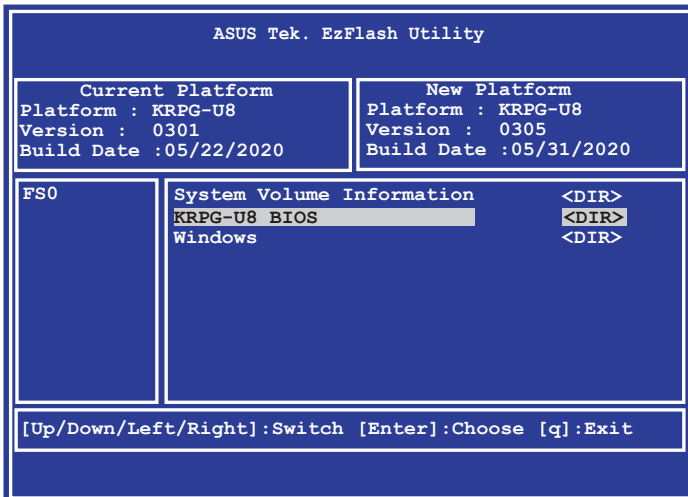

3. Press <Tab> to switch to the **Drive** field.
4. Press the Up/Down arrow keys to find the USB flash disk that contains the latest BIOS, then press <Enter>.
5. Press <Tab> to switch to the **Folder Info** field.
6. Press the Up/Down arrow keys to find the BIOS file, and then press <Enter> to perform the BIOS update process. Reboot the system when the update process is done.



- This function can support devices such as a USB flash disk with FAT 32/16 format and single partition only.
- DO NOT shut down or reset the system while updating the BIOS to prevent system boot failure!



Ensure to load the BIOS default settings to ensure system compatibility and stability. Press <F5> and select **Yes** to load the BIOS default settings.

### 4.1.3 BUPDATER utility



The succeeding BIOS screens are for reference only. The actual BIOS screen displays may not be the same as shown.

The BUPDATER utility allows you to update the BIOS file in the DOS environment using a bootable USB flash disk drive with the updated BIOS file.

#### Updating the BIOS file

To update the BIOS file using the BUPDATER utility:

1. Visit the ASUS website at [www.asus.com](http://www.asus.com) and download the latest BIOS file for the motherboard. Save the BIOS file to a bootable USB flash disk drive.
2. Copy the BUPDATER utility (BUPDATER.exe) from the ASUS support website at [www.asus.com/support](http://www.asus.com/support) to the bootable USB flash disk drive you created earlier.
3. Boot the system in DOS mode, then at the prompt, type:

```
BUPDATER /i[filename].CAP
```

where [filename] is the latest or the original BIOS file on the bootable USB flash disk drive, then press <Enter>.

```
A:\>BUPDATER /i[file name].CAP
```

- The utility verifies the file, then starts updating the BIOS file.

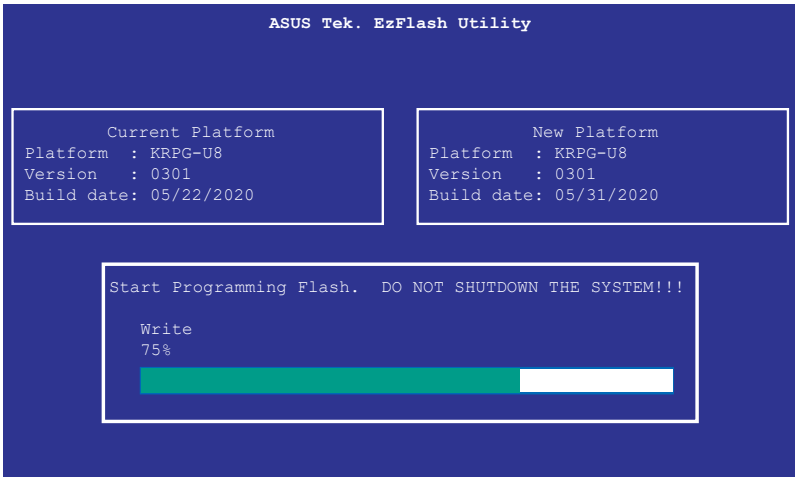

DO NOT shut down or reset the system while updating the BIOS to prevent system boot failure!

- The utility returns to the DOS prompt after the BIOS update process is completed. Reboot the system from the hard disk drive.

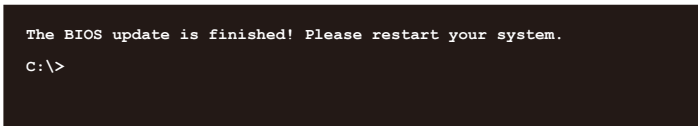

## 4.2 BIOS setup program

This motherboard supports a programmable firmware chip that you can update using the provided utility described in **Managing and updating your BIOS** section.

Use the BIOS Setup program when you are installing a motherboard, reconfiguring your system, or prompted to “Run Setup.” This section explains how to configure your system using this utility.

Even if you are not prompted to use the Setup program, you can change the configuration of your computer in the future. For example, you can enable the security password feature or change the power management settings. This requires you to reconfigure your system using the BIOS Setup program so that the computer can recognize these changes and record them in the CMOS RAM of the firmware chip.

The firmware chip on the motherboard stores the Setup utility. When you start up the computer, the system provides you with the opportunity to run this program. Press <Del> during the Power-On Self-Test (POST) to enter the Setup utility; otherwise, POST continues with its test routines.

If you wish to enter Setup after POST, restart the system by pressing <Ctrl>+<Alt>+<Delete>, or by pressing the reset button on the system chassis. You can also restart by turning the system off and then back on. Do this last option only if the first two failed.

The Setup program is designed to make it as easy to use as possible. Being a menu-driven program, it lets you scroll through the various sub-menus and make your selections from the available options using the navigation keys.



- 
- The default BIOS settings for this motherboard apply for most conditions to ensure optimum performance. If the system becomes unstable after changing any BIOS settings, load the default settings to ensure system compatibility and stability. Press <F5> and select **Yes** to load the BIOS default settings.
  - The BIOS setup screens shown in this section are for reference purposes only, and may not exactly match what you see on your screen.
  - Visit the ASUS website ([www.asus.com](http://www.asus.com)) to download the latest BIOS file for this motherboard.
-

## 4.2.1 BIOS menu screen

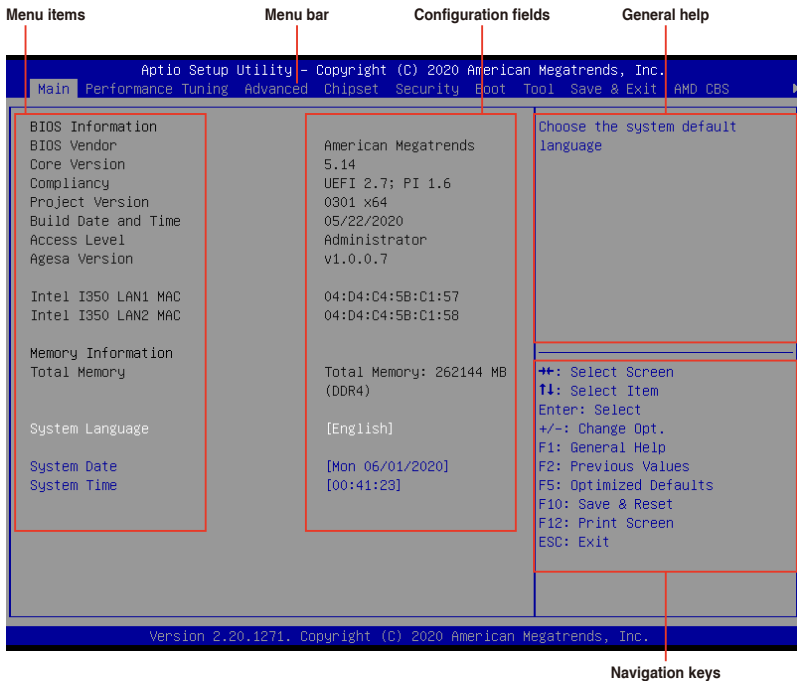

## 4.2.2 Menu bar

The menu bar on top of the screen has the following main items:

- |                           |   |
|---------------------------|---|
| <b>Main</b>               | For changing the basic system configuration   |
| <b>Performance Tuning</b> | For changing performance related settings     |
| <b>Advanced</b>           | For changing the advanced system settings     |
| <b>Chipset</b>            | For changing the chipset settings             |
| <b>Security</b>           | For changing the security settings            |
| <b>Boot</b>               | For changing the system boot configuration    |
| <b>Tool</b>               | For configuring options for special functions |
| <b>Save &amp; Exit</b>    | For selecting the exit options                |
| <b>AMD CBS</b>            | For configuring AMD CBS settings              |
| <b>Event Logs</b>         | For changing the event log settings           |
| <b>Server Mgmt</b>        | For changing the Server Mgmt settings         |

To select an item on the menu bar, press the right or left arrow key on the keyboard until the desired item is highlighted.

## Menu items

The highlighted item on the menu bar displays the specific items for that menu. For example, selecting **Main** shows the Main menu items.

The other items (such as **Advanced**) on the menu bar have their respective menu items.

## Submenu items

A solid triangle before each item on any menu screen means that the item has a submenu. To display the submenu, select the item then press <Enter>.

## Navigation keys

At the bottom right corner of a menu screen are the navigation keys for the BIOS setup program. Use the navigation keys to select items in the menu and change the settings.

## General help

At the top right corner of the menu screen is a brief description of the selected item.

## Configuration fields

These fields show the values for the menu items. If an item is user-configurable, you can change the value of the field opposite the item. You cannot select an item that is not user-configurable.

A configurable field is enclosed in brackets, and is highlighted when selected. To change the value of a field, select it and press <Enter> to display a list of options.

## Pop-up window

Select a menu item and press <Enter> to display a pop-up window with the configuration options for that item.

## Scroll bar

A scroll bar appears on the right side of a menu screen when there are items that do not fit on the screen. Press the Up/Down arrow keys or <Page Up> / <Page Down> keys to display the other items on the screen.



## 4.3 Main menu

When you enter the BIOS Setup program, the Main menu screen appears. The Main menu provides you an overview of the basic system information, and allows you to set the system date, time, language, and security settings.

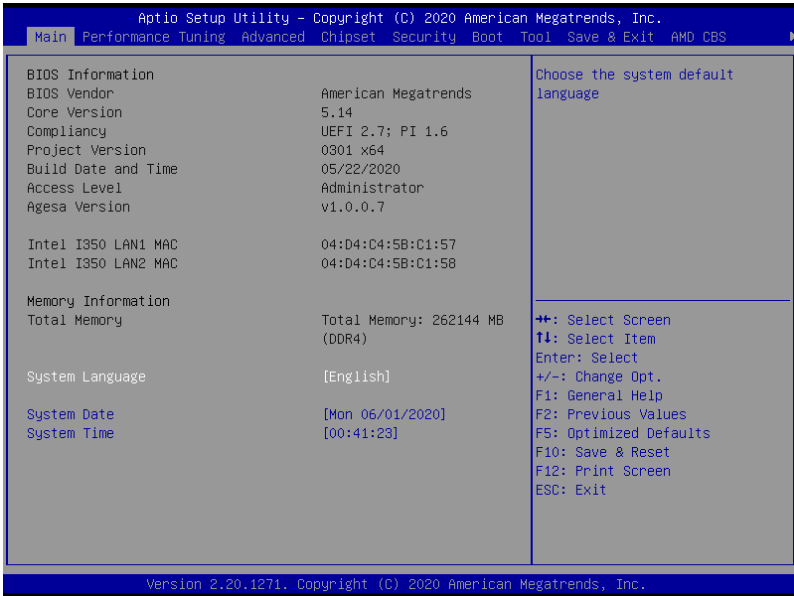

### System Language

Allows you to set the system language.

### System Date [MM/DD/YYYY]

Allows you to set the system date.

### System Time [HH:MM:SS]

Allows you to set the system time.

## 4.4 Performance Tuning menu

The Performance Tuning menu items allow you to change performance related settings for different scenarios.

Item	Setting	Description
Optimized Performance Setting	[Default]	Dynamically adjusts the frequency of all CPU cores based on their current utilization, delivering better performance per watt for improved system energy
Core Optimizer	[Disabled]	
Engine Boost	[Disabled]	
Overclocking	[Disabled]	
Power Balancer	[Disabled]	

### Optimized Performance Setting [Default]

Allows you to select performance settings for different scenarios.

[Default] Default settings.

[By Benchmark] Optimize for different kinds of benchmarks. Select this option, then select a benchmark type from the >> list.

[By Workload] Optimize for different kinds of workloads. Select this option, then select a workload type from the >> list.



---

The following item appears only when **Power Balancer** is set to **[Disabled]**.

---

### Core Optimizer [Disabled]

Allows you to keep the processor operating at the turbo highest frequency for the maximum performance. For Windows Server 2019, please set `Powercfg /setacvalueindex scheme_current sub_processor perfautonomous 1` & `Powercfg /setactive scheme_current` to enable this feature. For Linux, please set `cpupower frequency-set -g performance`.

Configuration options: [Disabled] [Enabled]



---

Linux support may vary by version of the OS.

---



---

The following item appears only when **Optimized Performance Setting** is set to **[Default]**.

---

### Engine Boost [Disabled]

Enable this item to boost the CPU's frequency.

Configuration options: [Disabled] [Enabled]



---

Operate with an ambient temperature of 25°C or lower for optimized performance.

---

## Overclocking [Disabled]

Enable this item to increase the CPU's clock. Please use an external PCIe storage controller for your hard drives when enabling this feature.

Configuration options: [Disabled] [Enabled]



Please note that overclocking might cause component damage or system crashes, which may reduce the lifespan of the system and the CPU. Use this tool at your own risk.

---

## Power Balancer [Disabled]

Allows you to dynamically adjust the frequency of all CPU cores based on their current utilization, delivering better performance per watt for improved system energy efficiency.

Configuration options: [Disabled] [Auto] [Manual]



When setting **Power Balancer** to **[Auto]** or **[Manual]**, make sure that you have the latest ASUS Control Center software installed to support Power Balancer. Please see below for recommended software versions:

- **ACC**: 1.4.3.5 version or above.

---



The following item appears only when set **Power Balancer** is set to **[Manual]**.

---

### CPU Max frequency [XXXX]

The default value for this option will be the maximum supported frequency of the CPU installed and may vary between different CPUs.

## 4.5 Advanced menu

The Advanced menu items allow you to change the settings for the CPU and other system devices.



Take caution when changing the settings of the Advanced menu items. Incorrect field values can cause the system to malfunction.

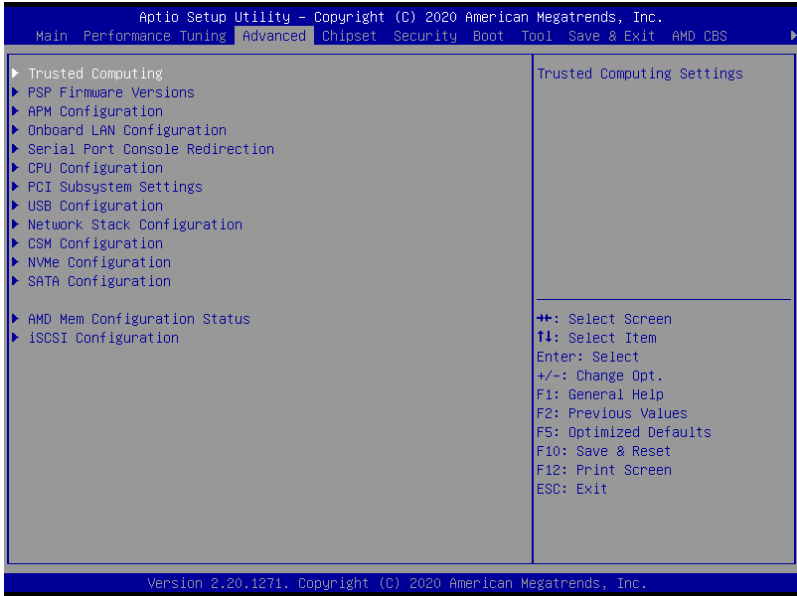

### 4.5.1 Trusted Computing

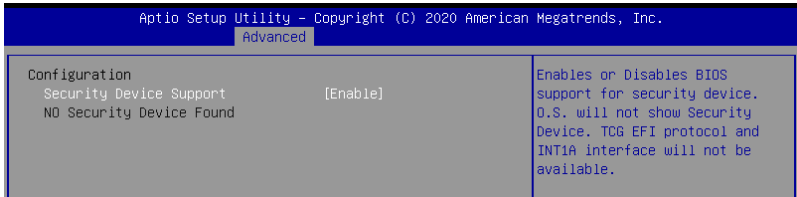

#### Configuration

##### Security Device Support [Enabled]

Allows you to enable or disable the BIOS support for security device.

Configuration options: [Disabled] [Enabled]

## 4.5.2 PSP Firmware Versions

This page displays the PSP firmware versions.

Aptio Setup Utility - Copyright (C) 2020 American Megatrends, Inc.	
Advanced	
PSP Firmware Versions	
PSP Directory Level 1 (Fixed)	
PSP Recovery BL Ver	FF.C.0.79
SMU FW Version	0.36.100.0
ABL Version	10072013
PSP Directory Level 2 (Updateable)	
PSP BootLoader Version	0.C.0.79
SMU FW Version	0.36.100.0
ABL Version	10072013

## 4.5.3 APM Configuration

Allows you to configure the Advance Power Management (APM) settings.

Aptio Setup Utility - Copyright (C) 2020 American Megatrends, Inc.		
Advanced		
Restore AC Power Loss	[Last State]	Restore On AC Power Loss
Power On By PCI-E/PCI	[Disabled]	
Power On By RTC	[Disabled]	

### Restore AC Power Loss [Last State]

When set to [Power Off], the system goes into off state after an AC power loss. When set to [Power On], the system will reboot after an AC power loss. When set to [Last State], the system goes into either off or on state, whatever the system state was before the AC power loss.

Configuration options: [Power Off] [Power On] [Last State]

### Power On By PCIE/PCI [Disabled]

[Disabled] Disables the PCIE devices to generate a wake event.

[Enabled] Enables the PCIE devices to generate a wake event.

### Power On By RTC [Disabled]

[Disabled] Disables RTC to generate a wake event.

[Enabled] When set to [Enabled], the items **RTC Alarm Date (Days)** and **Hour/Minute/Second** will become user-configurable with set values.

## 4.5.4 Onboard LAN Configuration

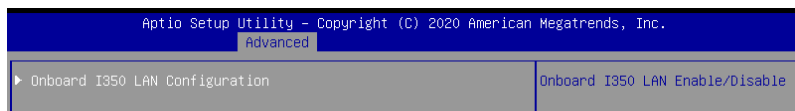

### Onboard I350 LAN Configuration

#### Intel I350 LAN1

##### LAN Enable [Jumperstate]

Allows you to enable or disable the Intel LAN.

Configuration options: [Disabled] [Jumperstate]



---

The following item appears only when **LAN Enable** is set to **[Jumperstate]**.

---

##### ROM Type [PXE]

Allows you to select the Intel LAN ROM type.

Configuration options: [Disabled] [PXE] [iSCSI]

#### Intel I350 LAN2

##### LAN Enable [Jumperstate]

Allows you to enable or disable the Intel LAN.

Configuration options: [Disabled] [Enabled]



---

The following item appears only when **LAN Enable** is set to **[Jumperstate]**.

---

##### ROM Type [Disabled]

Allows you to select the Intel LAN ROM type.

Configuration options: [Disabled] [PXE] [iSCSI]

## 4.5.5 Serial Port Console Redirection

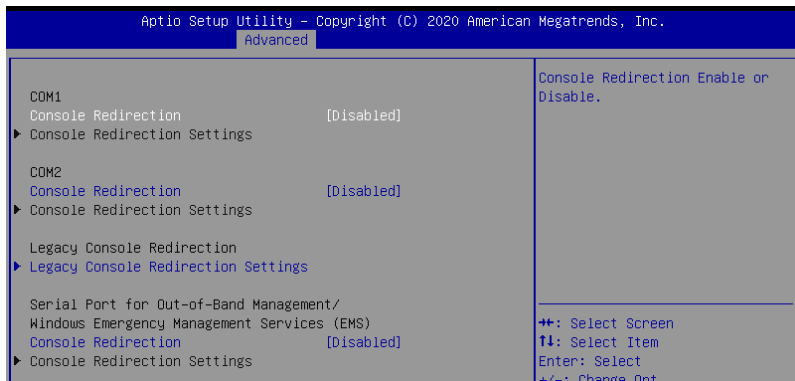

### COM1/COM2

#### Console Redirection [Disabled]

Allows you to enable or disable the console redirection feature.

Configuration options: [Disabled] [Enabled]



The following item appears only when **Console Redirection** is set to **[Enabled]**.

#### Console Redirection Settings

These items become configurable only when you enable the **Console Redirection** item. The settings specify how the host computer and the remote computer (which the user is using) will exchange data. Both computers should have the same or compatible settings.

#### Terminal Type [ANSI]

Allows you to set the terminal type.

- [VT100] ASCII char set.
- [VT100+] Extends VT100 to support color, function keys, etc.
- [VT-UTF8] Uses UTF8 encoding to map Unicode chars onto 1 or more bytes.
- [ANSI] Extended ASCII char set.

#### Bits per second [115200]

Selects serial port transmission speed. The speed must be matched on the other side. Long or noisy lines may require lower speeds.

Configuration options: [9600] [19200] [38400] [57600] [115200]

#### Data Bits [8]

Configuration options: [7] [8]

### **Parity [None]**

A parity bit can be sent with the data bits to detect some transmission errors. [Mark] and [Space] parity do not allow for error detection.

[None]	None
[Even]	parity bit is 0 if the num of 1's in the data bits is even
[Odd]	parity bit is 0 if num of 1's in the data bits is odd
[Mark]	parity bit is always 1
[Space]	parity bit is always 0

### **Stop Bits [1]**

Stop bits indicate the end of a serial data packet. (A start bit indicates the beginning.) The standard setting is 1 stop bit. Communication with slow devices may require more than 1 stop bit.

Configuration options: [1] [2]

### **Flow Control [None]**

Flow control can prevent data loss from buffer overflow. When sending data, if the receiving buffers are full, a "stop" signal can be sent to stop the data flow. Once the buffers are empty, a "start" signal can be sent to re-start the flow. Hardware flow control uses two wires to send start/stop signals.

Configuration options: [None] [Hardware RTS/CTS]

### **VT -UTF8 Combo Key Support [Enabled]**

This allows you to enable the VT -UTF8 Combination Key Support for ANSI/VT100 terminals.

Configuration options: [Disabled] [Enabled]

### **Recorder Mode [Disabled]**

With this mode enabled only text will be sent. This is to capture Terminal data.

Configuration options: [Disabled] [Enabled]

### **Resolution 100x31 [Enabled]**

This allows you to set the number of rows and columns supported on the Legacy OS.

Configuration options: [Disabled] [Enabled]

### **Putty Keypad [VT100]**

This allows you to select the FunctionKey and Keypad on Putty.

Configuration options: [VT100] [LINUX] [XTERMR6] [SCO] [ESCN] [VT400]

## **Legacy Console Redirection Settings**

### **Redirection COM Port [COM1]**

Allows you to select a COM port to display redirection of Legacy OS and Legacy OPRM Messages.

Configuration options: [COM1] [COM2]

### **Resolution [80x24]**

This allows you to set the number of rows and columns supported on the Legacy OS.

Configuration options: [80x24] [80x25]



## Redirection After BIOS POST [Always Enable]

This setting allows you to specify if Bootloader is selected than Legacy console redirection.  
Configuration options: [Always Enable] [Bootloader]

## Serial Port for Out-of-Band Management/Windows Emergency Management Services (EMS)

### Console Redirection [Disabled]

Allows you to enable or disable the console redirection feature.  
Configuration options: [Disabled] [Enabled]



The following item appears only when **Console Redirection** is set to **[Enabled]**.

### Console Redirection Settings

#### Out-of-Band Mgmt Port [COM1]

Microsoft Windows Emergency Management Services (EMS) allow for remote management of a Windows Server OS through a serial port.  
Configuration options: [COM1] [COM2]

#### Terminal Type [VT-UTF8]

Microsoft Windows Emergency Management Services (EMS) allow for remote management of a Windows Server OS through a serial port.  
Configuration options: [VT100] [VT100+] [VT-UTF8] [ANSI]

#### Bits per second [115200]

Microsoft Windows Emergency Management Services (EMS) allow for remote management of a Windows Server OS through a serial port.  
Configuration options: [9600] [19200] [57600] [115200]

#### Flow Control [None]

Microsoft Windows Emergency Management Services (EMS) allow for remote management of a Windows Server OS through a serial port.  
Configuration options: [None] [Hardware RTS/CTS] [Software Xon/Xoff]

## 4.5.6 CPU Configuration

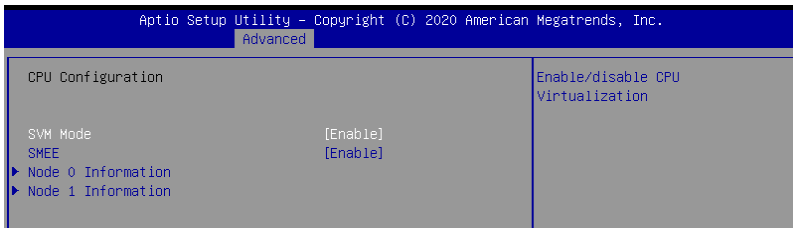

### SVM Mode [Enable]

This item allows you enable or disable CPU Virtualization.  
Configuration options: [Disabled] [Enable]

## SMEE [Enable]

This item allows you to enable or disable control secure memory encryption.  
Configuration options: [Disabled] [Enable]

## Node 0 Information

This item allows you to view memory information related to Node 0.

## Node 1 Information

This item allows you to view memory information related to Node 1.

## 4.5.7 PCI Subsystem Settings

Allows you to configure PCI, PCI-X, and PCI Express Settings.

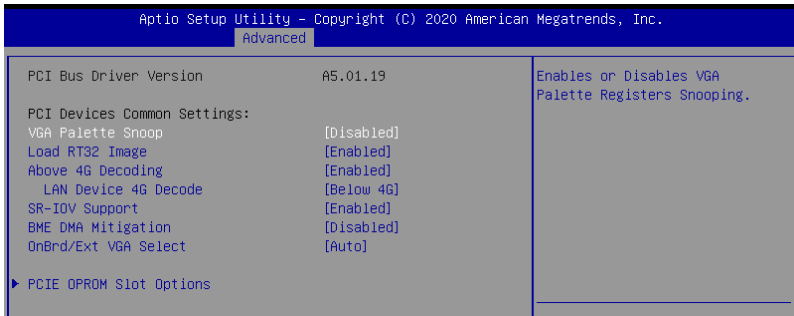

### VGA Palette Snoop [Disabled]

Allows you to enable or disable VGA Palette Registers Snooping.  
Configuration options: [Disabled] [Enabled]

### Load RT32 Image [Enabled]

Allows you to enable or disable RT32 Image Loading.  
Configuration options: [Disabled] [Enabled]

### Above 4G Decoding [Enabled]

Allows you to enable or disable 64-bit capable devices to be decoded in above 4G address space. It only works if the system supports 64-bit PCI decoding.  
Configuration options: [Disabled] [Enabled]



The following item appears only when **Above 4G Decoding** is set to **[Enabled]**.

### Lan device 4G Decode [Below 4G]

Configuration options: [Above 4G] [Below 4G]

### SR-IOV Support [Enabled]

This option enables or disables Single Root IO Virtualization Support if the system has SR-IOV capable PCIe devices.  
Configuration options: [Disabled] [Enabled]

### **BME DMA Mitigation [Disabled]**

This allows you to enable or disable re-enabling Bus Master Attribute disabled during PCI enumeration for PCI Bridges after SMM locked.

Configuration options: [Disabled] [Enabled]

### **OnBrd/Ext VGA Select [Auto]**

This allows you to select between onboard or external VGA support.

Configuration options: [Auto] [Onboard] [External]

### **PCIE OPROM Slot Options**

The items in this option allows you to select the OPROM configurations for slots.

### **PCIE OPROM Slot Options**

The items in this option allows you to select the OPROM configurations for slots.

## **4.5.8 USB Configuration**

Aptio Setup Utility - Copyright (C) 2020 American Megatrends, Inc.	
Advanced	
USB Configuration	Enables Legacy USB support. AUTO option disables legacy support if no USB devices are connected. DISABLE option will keep USB devices available only for EFI applications.
USB Module Version	24
USB Controllers:	
2 XHCIs	
USB Devices:	
2 Drives, 2 Keyboards, 2 Mice, 4 Hubs	
Legacy USB Support	[Enabled]
XHCI Hand-off	[Enabled]
USB Mass Storage Driver Support	[Enabled]
Port 60/64 Emulation	[Enabled]
USB hardware delays and time-outs:	
USB transfer time-out	[20 sec]
Device reset time-out	[20 sec]
Device power-up delay	[Auto]
Mass Storage Devices:	
AMI Virtual CDROM 1.00	[Auto]
JetFlashTranscend 4GB 8.07	[Auto]
	<b>++:</b> Select Screen <b>F1:</b> Select Item Enter: Select +/-: Change Opt. F1: General Help F2: Previous Values F5: Optimized Defaults F10: Save & Reset F12: Print Screen ESC: Exit

### **Legacy USB Support [Enabled]**

Allows you to enable or disable Legacy USB device support.

Configuration options: [Enabled] [Disabled] [Auto]

### **XHCI Hand-off [Enabled]**

Allows you to enable or disable workaround for OSES without XHCI hand-off support. The XHCI ownership change should be claimed by XHCI driver.

Configuration options: [Enabled] [Disabled]

### **USB Mass Storage Driver Support [Enabled]**

Allows you to enable or disable the USB Mass Storage driver support.

Configuration options: [Disabled] [Enabled]

### Port 60/64 Emulation [Enabled]

Allows you to enable or disable I/O port 60h/64h emulation support. This should be enabled for the complete keyboard legacy support for non-USB aware OSes.  
onfiguration options: [Disabled] [Enabled]

### USB hardware delays and time-outs

#### USB transfer time-out [20 sec]

Allows you to select time-out value for Control, Bulk, and Interrupt transfers.  
Configuration options: [1 sec] [5 sec] [10 sec] [20 sec]

#### Device reset time-out [20 sec]

Allows you to select time-out value for USB mass storage device Start Unit command.  
Configuration options: [10 sec] [20 sec] [30 sec] [40 sec]

#### Device power-up delay [Auto]

Allows you to select maximum time the device will take before it properly reports itself to the Host Controller. **[Auto]** uses the default value, for a Root port, it is 100 ms. For a Hub port, the delay is taken from Hub descriptor.  
Configuration options: [Auto] [Manual]



---

The following item appears only when **Device power-up delay** is set to **[Manual]**.

---

#### Device power-up delay in seconds [5]

Allows you to set the device power-up delay in seconds. Use the <+> or <-> to adjust the value. The values range from 1 to 40.

### Mass Storage Devices

Allows you to select the mass storage device emulation type for devices connected.  
Configuration options: [Auto] [Floppy] [Forced FDD] [Hard Disk] [CD-ROM]

## 4.5.9 Network Stack Configuration

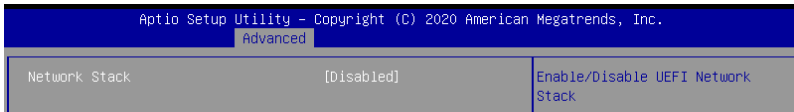

#### Network stack [Disabled]

Enables or disables the network stack feature.  
Configuration options: [Disable] [Enable]



---

The following items appear only when **Network stack** is set to **[Enabled]**.

---

#### Ipv4 PXE Support [Disabled]

Enables or disables the Ipv4 PXE Boot Support. If disabled, Ipv4 PXE boot option will not be created.  
Configuration options: [Disabled] [Enabled]

### Ipv4 HTTP Support [Disabled]

Enables or disables the Ipv4 HTTP Boot Support. If disabled, Ipv4 HTTP boot option will not be created.

Configuration options: [Disabled] [Enabled]

### Ipv6 PXE Support [Disabled]

Enables or disables the Ipv6 PXE Boot Support. If disabled, Ipv6 PXE boot option will not be created.

Configuration options: [Disabled] [Enabled]

### Ipv6 HTTP Support [Disabled]

Enables or disables the Ipv6 HTTP Boot Support. If disabled, Ipv6 HTTP boot option will not be created.

Configuration options: [Disabled] [Enabled]

### PXE boot wait time [0]

Wait time to press ESC key to abort the PXE boot.

### Media detect time [1]

Wait time (in seconds) to detect media.

## 4.5.10 CSM Configuration

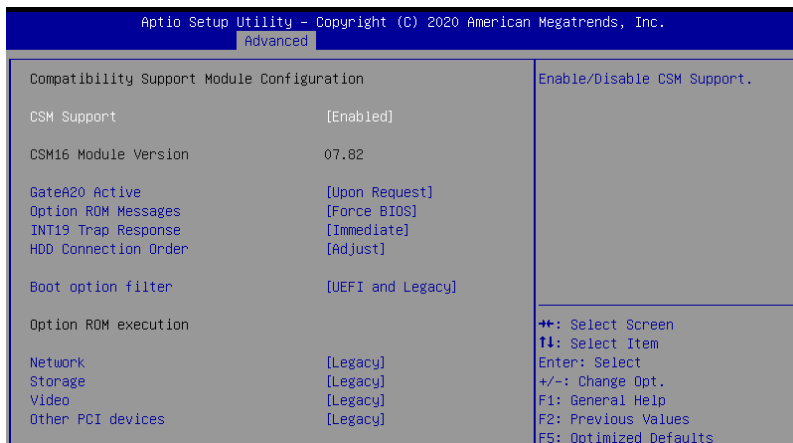

### CSM Support [Enabled]

This option allows you to enable or disable CSM Support.

Configuration options: [Disabled] [Enabled]



The following items appear only when **CSM Support** is set to **[Enabled]**.

### GateA20 Active [Upon Request]

This allows you to set the GA20 option.

Configuration options: [Upon Request] [Always]

### Option ROM Messages [Force BIOS]

This allows you to set the display mode for option ROM.  
Configuration options: [Force BIOS] [Keep Current]

### INT19 Trap Response [Immediate]

This allows you to select the BIOS reaction on INT19 trapping by Option ROM.  
[Immediate]           Execute the trap right away.  
[Postponed]           Execute the trap during legacy boot.

### HDD Connection Order [Adjust]

This option allows you to select the HDD Connection Order. Some OS require HDD handles to be adjusted.  
Configuration options: [Adjust] [Keep]

### Boot Option filter [UEFI and Legacy]

This option allows you to control the Legacy/UEFI ROMs priority.  
Configuration options: [UEFI and Legacy] [Legacy only] [UEFI only]

### Network / Storage / Video [Legacy]

This option allows you to control the execution of UEFI and Legacy Network / Storage / Video OpROM.  
Configuration options: [UEFI] [Legacy]

### Other PCI devices [Legacy]

This item determines the OpROM execution policy for devices other than Network, Storage, or Video.  
Configuration options: [UEFI] [Legacy]

## 4.5.11 NVMe Configuration

This page will display the NVMe controller and drive information.

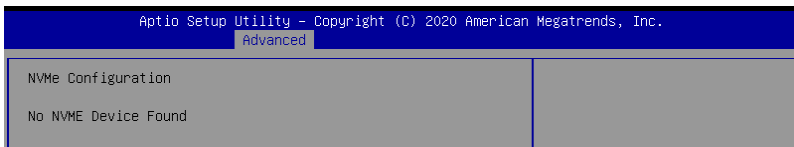

## 4.5.12 SATA Configuration

This page will display the SATA controller and drive information.

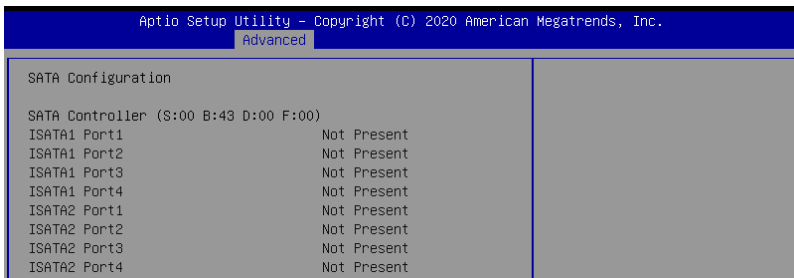

## 4.5.13 AMD Mem Configuration Status

The items in this menu display the memory configuration (initialized by ABL) status.

Aptio Setup Utility - Copyright (C) 2020 American Megatrends, Inc.		
Advanced		
▶ Socket 0		Socket-specific memory configuration status
Mbist Test Enable	Disabled, 0xC003	
Mbist Aggressor Enable	Disabled, 0xC000	
Mbist Per Bit Slave Die Report	0x0000, 0xC000	
Dram Temp Controlled Refresh Enable	Disabled, 0xC000	
User Timing Mode	Disabled, 0xC015	
User Timing Value	Disabled, 0xC015	
Mem Bus Freq Limit	Disabled, 0xC015	
Enable Power Down	Disabled, 0xC000	
Dram Double Refresh Rate	Disabled, 0xC000	
Pmu Train Mode	0x0003, 0xC000	
Ecc Symbol Size	0x0002, 0xC000	
Uncorrectable Ecc Retry	Enabled, 0xC000	++: Select Screen
Ignore Spd Checksum	Enabled, 0xC000	↑↓: Select Item
Enable Bank Group Swap Alt	Enabled, 0xC000	Enter: Select
Enable Bank Group Swap	Disabled, 0xC01A	+/-: Change Opt.
Ddr Route Balanced Tee	Disabled, 0xC000	F1: General Help
Nvdimm Power Source	0x0001, 0xC000	F2: Previous Values
Odts Cmd Throt Enable	Disabled, 0xC004	F5: Optimized Defaults
Odts Cmd Throt Cycle	Disabled, 0xC004	F10: Save & Reset
		F12: Print Screen

## 4.5.14 iSCSI Configuration

Allows you to configure the iSCSi parameters.

Aptio Setup Utility - Copyright (C) 2017 American Megatrends, Inc.	
Advanced	
iSCSI Initiator Name	The worldwide unique name of iSCSI Initiator. Only IQN format is accepted. Range is from 4 to 223
▶ Add an Attempt	
▶ Delete Attempts	
▶ Change Attempt Order	

## 4.6 Chipset menu

The Chipset menu items allow you to change the Chipset settings.

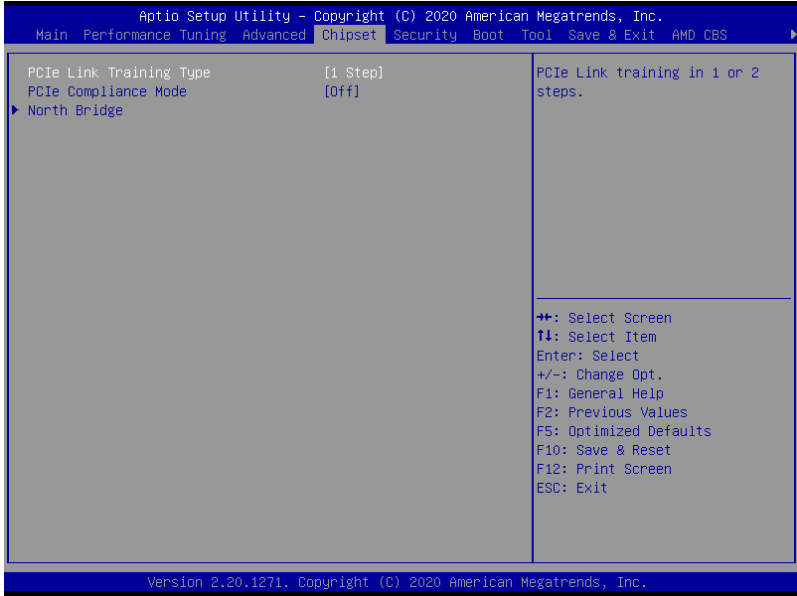

### PCIe Link Training Type [1 Step]

This item allows you to select PCIe Link Training in 1 or 2 steps.  
Configuration options: [1 Step] [2 Step]

### PCIe Compliance Mode [Off]

This item allows you to turn the PCIe Compliance Mode on or off.  
Configuration options: [On] [Off]

### North Bridge

#### Socket 0 Information

This item displays the memory information on Socket 0.

#### Socket 1 Information

This item displays the memory information on Socket 1.



## 4.7 Security menu

This menu allows a new password to be created or a current password to be changed. The menu also enables or disables the Secure Boot state and lets the user configure the System Mode state.

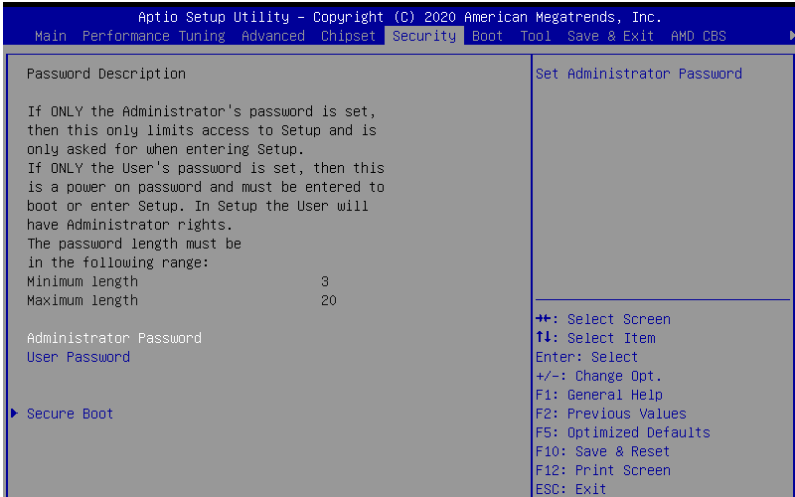

### Administrator Password

To set an administrator password:

1. Select the Administrator Password item and press <Enter>.
2. From the Create New Password box, key in a password, then press <Enter>.
3. Confirm the password when prompted.

To change an administrator password:

1. Select the Administrator Password item and press <Enter>.
2. From the Enter Current Password box, key in the current password, then press <Enter>.
3. From the Create New Password box, key in a new password, then press <Enter>.
4. Confirm the password when prompted.



To clear the administrator password, follow the same steps as in changing an administrator password, but press <Enter> when prompted to create/confirm the password.

## User Password

To set a user password:

1. Select the User Password item and press <Enter>.
2. From the Create New Password box, key in a password, then press <Enter>.
3. Confirm the password when prompted.

To change a user password:

1. Select the User Password item and press <Enter>.
2. From the Enter Current Password box, key in the current password, then press <Enter>.
3. From the Create New Password box, key in a new password, then press <Enter>.
4. Confirm the password when prompted.

To clear a user password:

1. Select the Clear User Password item and press <Enter>.
2. Select **Yes** from the Warning message window then press <Enter>.

## Secure Boot

This item allows you to customize the Secure Boot settings.

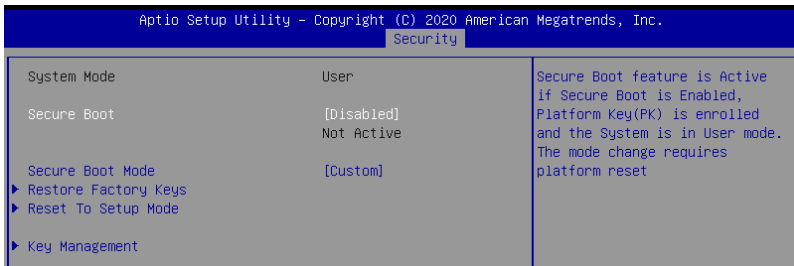

### Secure Boot [Disabled]

Secure Boot can be enabled if the system is running in User mode with enrolled platform Key (EPK) or if the CSM function is disabled.

Configuration options: [Disabled] [Enabled]

### Secure Boot Mode [Custom]

Allows you to set the Secure Boot selector.

Configuration options: [Custom] [Standard]

### Restore Factory Keys

This option will force the system to User Mode, and install factory default Secure Boot key databases.

### Reset to Setup Mode

This option will delete all Secure Boot key databases from NVRAM.

## Key Management

This item only appears when the item Secure Boot Mode is set to [Custom]. The Key Management item allows you to modify Secure Boot variables and set Key Management page.

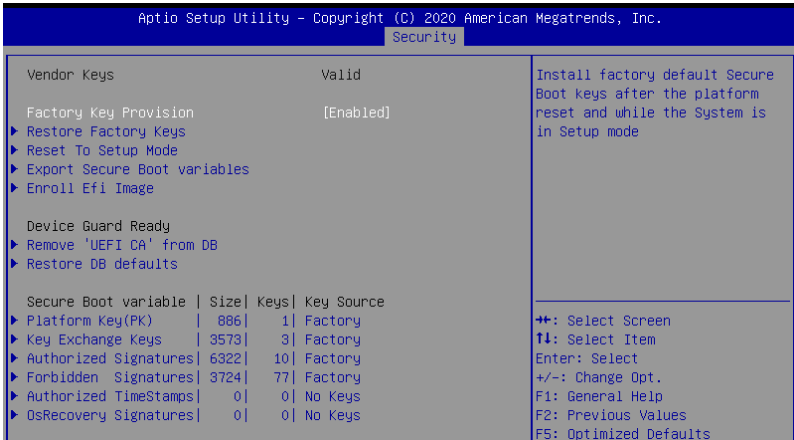

### Factory Key Provision [Disabled]

Allows you to provision factory default Secure Boot keys when the system is in Setup Mode.

Configuration options: [Disabled] [Enabled]

### Restore Factory keys

This item will install all Factory Default keys.

### Reset to Setup Mode

This item appears only when you load the default Secure Boot keys. This item allows you to clear all default Secure Boot keys.

### Export Secure Boot Variables

This item will ask you if you want to save all secure boot variables. Select Yes if you want to save all secure boot variables, otherwise select No.

### Enroll Efi Image

This item will allow the image to run in Secure Boot mode.

Configuration options: [Set New] [Append]

### Device Guard Ready

### Remove 'UEFI CA' from DB

Remove Microsoft UEFI CA from Secure Boot DB.

### Restore DB defaults

Restore DB variable to factory defaults.

### Platform Key (PK)

Configuration options: [Details] [Export] [Update] [Delete]

## Key Exchange Keys (KEK) / Authorized Signatures (DB) / Forbidden Signatures (DBX)

Configuration options: [Details] [Export] [Update] [Append] [Delete]

## Authorized TimeStamps (DBT) / OsRecovery Signatures

Configuration options: [Update] [Append]

## 4.8 Boot menu

The Boot menu items allow you to change the system boot options.

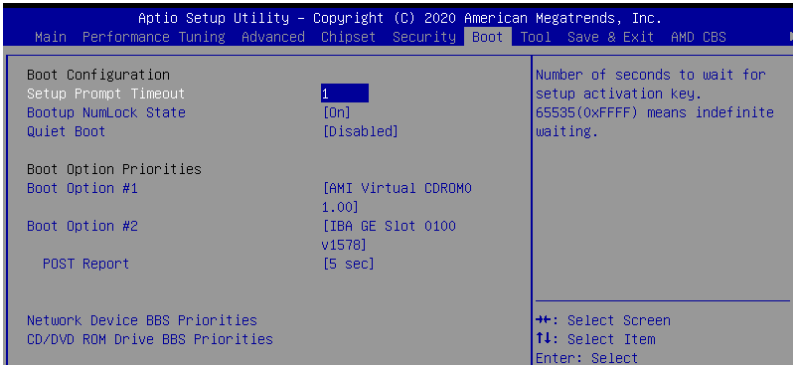

### Setup Prompt Timeout [1]

Allows you to set the number of seconds that the firmware waits before initiating the original default boot selection. 65535(0xFFFF) means indefinite waiting. Use the <+> or <-> to adjust the value.

### Bootup NumLock State [On]

Allows you to select the power-on state for the NumLock.

Configuration options: [Off] [On]

### Quiet Boot [Disabled]

Allows you to enable or disable Quiet Boot option.

Configuration options: [Disabled] [Enabled]

### Boot Option Priorities

These items specify the boot device priority sequence from the available devices. The number of device items that appears on the screen depends on the number of devices installed in the system.



- To select the boot device during system startup, press <F8> when ASUS Logo appears.
- To access Windows OS in Safe Mode, please press <F8> after POST.

### POST Report [5 sec]

Allows you to set the desired POST Report waiting time from 1 to 10 seconds.

Configuration options: [1 sec] ~ [10 sec] [Until Press ESC]

## Network Device BBS Priorities / CD/DVD ROM Drive BBS Priorities

These items appear only when you connect a network cable or SATA ODD to the SATA port, and allows you to set the booting order of the Network / SATA devices.

## 4.9 Tool menu

The Tool menu items allow you to configure options for special functions. Select an item then press <Enter> to display the submenu.

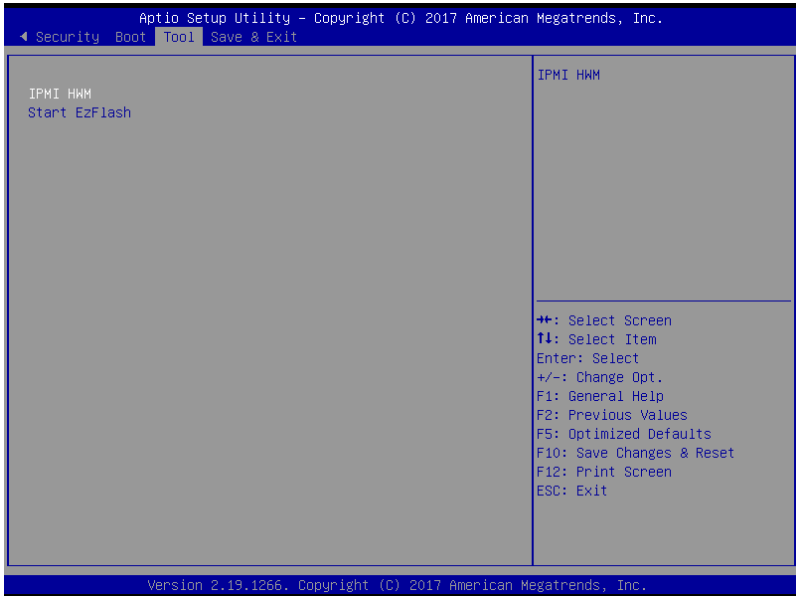

### IPMI HWM

Allows you to run the IPMI hardware monitor.

### Start ASUS EzFlash

Allows you to run ASUS EZ Flash BIOS ROM Utility when you press <Enter>. Refer to the **ASUS EZ Flash Utility** section for details.

# 4.10 Save & Exit menu

The Save & Exit menu items allow you to save or discard your changes to the BIOS items.

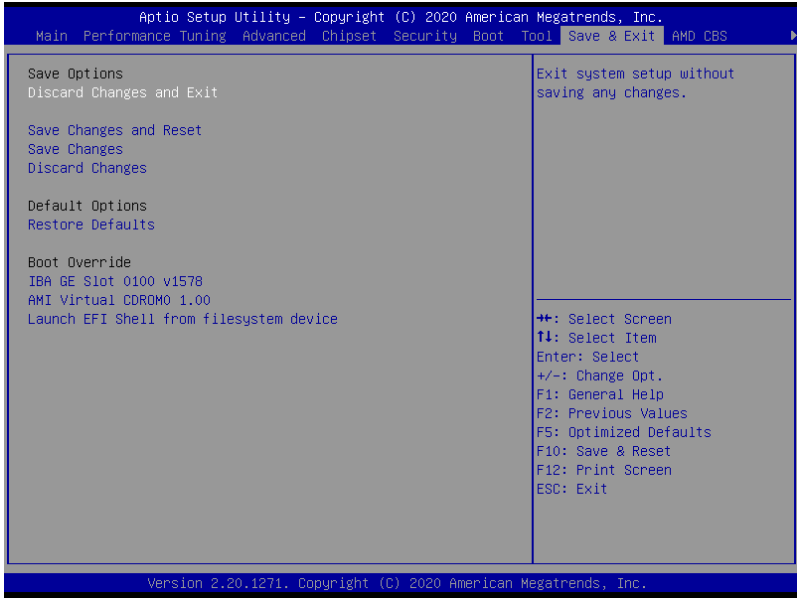

## Discard Changes and Exit

Exit System setup without saving any changes.

## Save Changes and Reset

Exit System setup after saving the changes.

## Save Changes

Save changes done so far to any of the setup options.

## Discard Changes

Discard changes done so far to any of the setup options.

## Restore Defaults

Restore/load default values for all the setup options.

## Boot Override

These items displays the available devices. The device items that appears on the screen depends on the number of devices installed in the system. Click an item to start booting from the selected device.

## Launch EFI Shell from filesystem device

This item allows you to attempt to launch the EFI Shell application (shellx64.efi) from one of the available filesystem devices.

## 4.11 AMD CBS menu

The items in this menu shows the AMD Common BIOS Specifications.

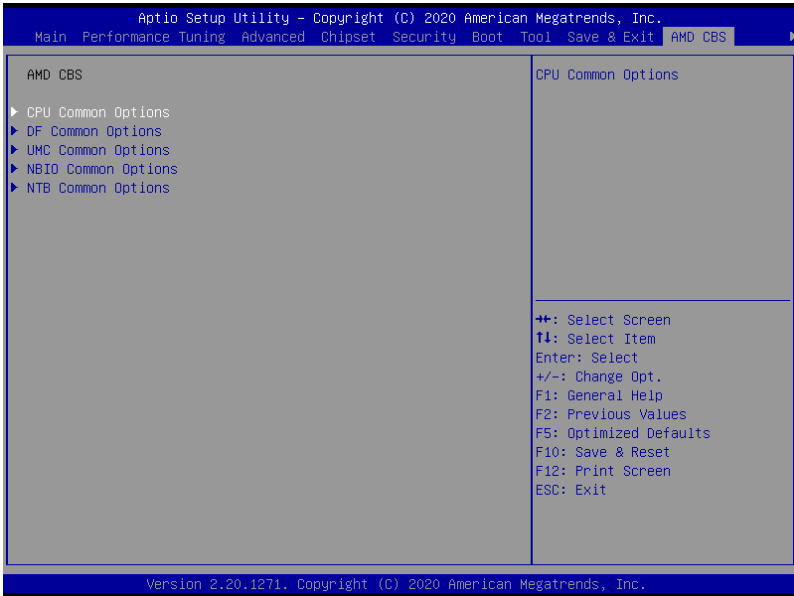

### 4.11.1 CPU Common Options

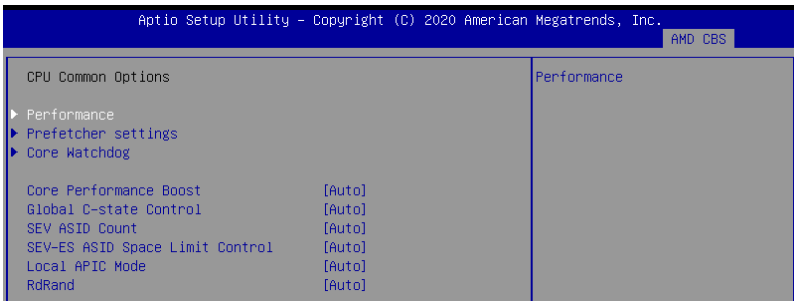

#### Performance

##### Custom Core Pstates

This item allows you to enable custom P-states and throttling.



Damage caused by use of your AMD processor outside of specification or in excess of factory settings are not covered by your system manufacturers warranty.

## CCD/Core/Thread Enhancement

This item allows you to set CCD/core/threads.



---

S3 is not supported on systems where cores/threads have been removed/disabled.

---

## Prefetcher settings

### L1 Stream HW Prefetcher [Auto]

This item allows you to enable or disable L1 Stream HW Prefetcher.  
Configuration options: [Disable] [Enable] [Auto]

### L2 Stream HW Prefetcher [Auto]

This item allows you to enable or disable L2 Stream HW Prefetcher.  
Configuration options: [Disable] [Enable] [Auto]

## Core Watchdog

### Core Watchdog Timer Enable [Auto]

This item allows you to enable or disable CPU Watchdog Timer.  
Configuration options: [Disabled] [Enabled] [Auto]



---

The following items appear only when **Core Watchdog Timer Enable** is set to **[Enabled]**.

---

### Core Watchdog Timer Interval [Auto]

Configuration options: [21.461s] [10.730s] [5.364s] [2.681s] [1.340s] [669.41ms] [334.05ms] [166.37ms] [82.53ms] [40.61ms] [20.970ms] [10.484ms] [5.241ms] [2.620ms] [1.309ms] [654.08us] [326.4us] [162.56us] [80.64us] [39.68us] [Auto]

### Core Watchdog Timer Severity [Auto]

Configuration options: [No Error] [Transparent] [Corrected] [Deferred] [Uncorrected] [Fatal] [Auto]

## Core Performance Boost [Auto]

This option allows you to enable or disable CPB.  
Configuration options: [Disabled] [Auto]

## Global C-state Control [Enabled]

This option allows you to control IO based C-state generation and DF C-states.  
Configuration options: [Disabled] [Enabled] [Auto]

## SEV ASID Count [Auto]

This field specifies the maximum valid ASID, which affects the maximum system physical address space. 16TB of physical address space is available for systems that support 253 ASIDs, while 8TB of physical address space is available for systems that support 509 ASIDs.  
Configuration options: [253 ASIDs] [509 ASIDs] [Auto]

## SEV-ES ASID Space Limit Control [Auto]

Configuration options: [Auto] [Manual]





The following item appears only when **SEV-ES ASID Space Limit Control** is set to **[Manual]**.

### SEV-ES ASID Space Limit [1]

SEV Vms using ASIDs below the SEV-ES ASID Space Limit must enable the SEV-ES feature. ASIDs from SEV-ES ASID Space Limit to (SEV ASID Count + 1) can only be used with SEV VMs. If this field is set to (SEV ASID Count + 1), all ASIDs are forced to be SEV-ES ASIDs. Hence, the valid values for this field is 1 - (SEV ASID Count + 1).

Configuration options: [1] - [520]

### Local APIC Mode [Auto]

Configuration options: [XAPIC] [X2APIC] [Auto]

### RdRand [Auto]

This item allows you to enable or disable RdRand instruction.

Configuration options: [Auto] [Enable] [Disable]

## 4.11.2 DF Common Options

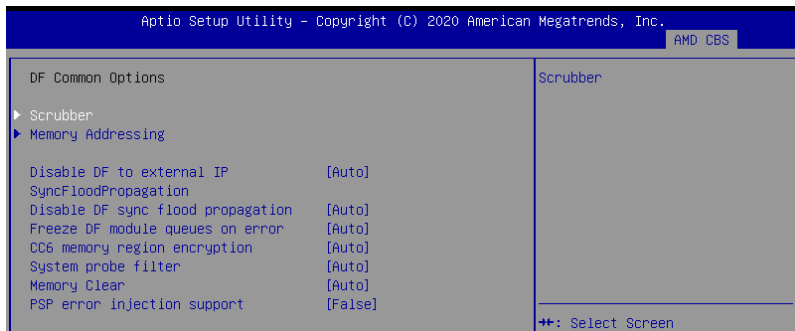

### Scrubber

#### DRAM scrub time [Auto]

This item allows you to set a number of hours to scrub memory.

Configuration options: [Disabled] [1 hour] [4 hours] [8 hours] [16 hours] [24 hours] [48 hours] [Auto]

#### Poison scrubber control [Auto]

Configuration options: [Disabled] [Enabled] [Auto]

#### Redirect scrubber control [Auto]

Configuration options: [Disabled] [Enabled] [Auto]

#### Redirect scrubber limit [Auto]

Configuration options: [2] [4] [8] [Infinite] [Auto]

#### Periodic Directory Rinse [Auto]

Configuration options: [Disabled] [Enabled] [Auto]

## Memory Addressing

### NUMA nodes per socket [Auto]

Specifies the number of desired NUMA nodes per socket. Zero will attempt to interleave the two sockets together.

Configuration options: [NPS0] [NPS1] [NPS2] [NPS4] [Auto]

### Memory interleaving [Auto]

This item allows for disabling memory interleaving. Note that NUMA nodes per socket will be honored regardless of this setting.

Configuration options: [Disabled] [Auto]

### Memory interleaving size [Auto]

This item controls the memory interleaving size. The valid values are AUTO, 256 bytes, 512 bytes, 1 Kbytes, or 2 Kbytes. This also determines the starting address of the interleave (bit 8, 9, 10, or 11).

Configuration options: [256 Bytes] [512 Bytes] [1 KB] [2 KB] [Auto]

### 1TB remap [Auto]

Attempt to remap DRAM out of the space just below the 1TB boundary. The ability to remap depends on DRAM configuration, NPS, and interleaving selection, and may not always be possible.

Configuration options: [Do not remap] [Attempt to remap] [Auto]

### DRAM map inversion [Auto]

Inverting the map will cause the highest memory channels to get assigned the lowest addresses in the system.

Configuration options: [Disabled] [Enabled] [Auto]

### Location of private memory regions [Auto]

Controls whether or not the private memory regions (PSP, SMU and CC6) are at the top of DRAM or distributed. Note that distributed requires memory on all dies. Note that it will always be at the top of DRAM if some dies don't have memory regardless of this option's setting.

Configuration options: [Distributed] [Consolidated] [Auto]

### Disable DF to external IP SyncFloodPropagation [Auto]

This item allows you to disable SyncFlood to UMC & downstream slaves.

Configuration options: [Sync flood disabled] [Sync flood enabled] [Auto]

### Disable DF sync flood propagation [Auto]

Configuration options: [Sync flood disabled] [Sync flood enabled] [Auto]

### Freeze DF module queues on error [Auto]

Configuration options: [Disabled] [Enabled] [Auto]

### CC6 memory region encryption [Auto]

This item allows you to control whether or not the CC6 save/restore memory is encrypted.

Configuration options: [Disabled] [Enabled] [Auto]

## System probe filter [Auto]

This item allows you to enable or disable the probe filter. This has no effect on parts where the probe filter is fuse disabled.

Configuration options: [Disabled] [Enabled] [Auto]

## Memory Clear [Auto]

When this item is set to [Disabled], BIOS does not implement MemClear after memory training (only if non-ECC DIMMs are used).

Configuration options: [Disabled] [Enabled] [Auto]

## PSP error injection support [False]

Configuration options: [False] [True]

## 4.11.3 UMC Common Option



### DDR4 Common Options

#### DRAM Timing Configuration

This item allows you to enable DRAM timing configuration.



Damage caused by use of your AMD processor outside of specification or in excess of factory settings are not covered by your system manufacturers warranty.

#### DRAM Controller Configuration

##### DRAM Power Options

##### Power Down Enable [Auto]

This item allows you to enable or disable power down mode.

Configuration options: [Disabled] [Enabled] [Auto]

##### Cmd2T [Auto]

Configuration options: [Auto] [1T] [2T]

##### Gear Down Mode [Auto]

Configuration options: [Auto] [Disabled] [Enabled]

#### CAD Bus Configuration

##### CAD Bus Timing User Controls [Auto]

This item allows you to set the CAD bus signals to Auto or Manual.

Configuration options: [Auto] [Manual]



The following items appear only when **CAD Bus Timing User Controls** is set to **[Manual]**.

##### AddrCmdSetup [0]

This item allows you to setup time on CAD bus signals.

Configuration options: [0] - [39]

### **CsOdtSetup [0]**

This item allows you to setup time on CAD bus signals.  
Configuration options: [0] - [39]

### **CkeSetup [0]**

This item allows you to setup time on CAD bus signals.  
Configuration options: [0] - [39]

### **CAD Bus Drive Strength User Controls [Auto]**

This item allows you to set the CAD bus signals to Auto or Manual.  
Configuration options: [Auto] [Manual]



---

The following items appear only when **CAD Bus Drive Strength User Controls** is set to **[Manual]**.

---

#### **ClkDrvStren [Auto]**

Configuration options: [Auto] [120.0 Ohm] [60.0 Ohm] [40.0 Ohm] [30.0 Ohm] [24.0 Ohm] [20.0 Ohm]

#### **AddrCmdDrvStren [Auto]**

Configuration options: [Auto] [120.0 Ohm] [60.0 Ohm] [40.0 Ohm] [30.0 Ohm] [24.0 Ohm] [20.0 Ohm]

#### **CsOdtDrvStren [Auto]**

Configuration options: [Auto] [120.0 Ohm] [60.0 Ohm] [40.0 Ohm] [30.0 Ohm] [24.0 Ohm] [20.0 Ohm]

#### **CkeDrvStren [Auto]**

Configuration options: [Auto] [120.0 Ohm] [60.0 Ohm] [40.0 Ohm] [30.0 Ohm] [24.0 Ohm] [20.0 Ohm]

## **Data Bus Configuration**

### **Data Bus Configuration User Controls [Auto]**

This item allows you to specify the mode for drive strength.  
Configuration options: [Auto] [Manual]



---

The following items appear only when **Data Bus Configuration User Controls** is set to **[Manual]**.

---

#### **RttNom [Auto]**

Configuration options: [Rtt\_Nom Disable] [RZQ/4] [RZQ/2] [RZQ/6] [RZQ/1] [RZQ/5] [RZQ/3] [RZQ/7] [Auto]

#### **RttWr [Auto]**

Configuration options: [Dynamic ODT Off] [RZQ/2] [RZQ/1] [Hi-Z] [RZQ/3] [Auto]

#### **RttPark [Auto]**

Configuration options: [Rtt\_PARK Disable] [RZQ/4] [RZQ/2] [RZQ/6] [RZQ/1] [RZQ/5] [RZQ/3] [RZQ/7] [Auto]

## **Common RAS**

### **Data Poisoning [Auto]**

Configuration options: [Enabled] [Disabled] [Auto]

### **DRAM Post Package Repair [Disable]**

This item allows you to enable or disable DRAM POST Package Repair.  
Configuration options: [Enable] [Disable]

### **RCD Parity [Auto]**

Configuration options: [Enabled] [Disabled] [Auto]

### **DRAM Address Command Parity Retry [Auto]**

Configuration options: [Enabled] [Disabled] [Auto]



The following item appears only when **DRAM Address Command Parity Retry** is set to **[Enabled]**.

### **Max Parity Error Replay [8]**

The values in hex, 1, 2, or 3 is invalid.

Configuration options: [0] - [39]

### **Write CRC Enable [Auto]**

Configuration options: [Enabled] [Disabled] [Auto]

### **DRAM Write CRC Enable and Retry Limit [Auto]**

Configuration options: [Enabled] [Disabled] [Auto]



The following item appears only when **DRAM Write CRC Enable and Retry Limit** is set to **[Enabled]**.

### **Max Write CRC Error Replay [8]**

The values in hex, 1, 2, or 3 is invalid.

Configuration options: [0] - [39]

### **Disable Memory Error Injection [True]**

Configuration options: [False] [True]

### **ECC Configuration**

#### **DRAM ECC Symbol Size [Auto]**

Configuration options: [x4] [x8] [x16] [Auto]

#### **DRAM ECC Enable [Auto]**

This option allows you to enable or disable DRAM ECC. Auto will set ECC to enable.

Configuration options: [Disabled] [Enabled] [Auto]

#### **DRAM UECC Retry [Auto]**

This option allows you to enable or disable DRAM UECC Retry.

Configuration options: [Disabled] [Enabled] [Auto]

## **Security**

### **TSME [Auto]**

Configuration options: [Disabled] [Enabled] [Auto]

### **Data Scramble [Auto]**

Configuration options: [Disabled] [Enabled] [Auto]

## **DRAM Memory Mapping**

### **Chipselect Interleaving [Auto]**

This item allows you to set interleave memory blocks across the DRAM chip selects for node 0.

Configuration options: [Disabled] [Auto]

### **BankGroupSwap [Auto]**

Configuration options: [Enabled] [Disabled] [Auto]

### **BankGroupSwapAlt [Auto]**

Configuration options: [Enabled] [Disabled] [Auto]

### **Address Hash Bank [Auto]**

This item allows you to enable or disable bank address hashing.

Configuration options: [Enabled] [Disabled] [Auto]

### **Address Hash CS [Auto]**

This item allows you to enable or disable CS address hashing.

Configuration options: [Enabled] [Disabled] [Auto]

### **Address Hash Rm [Auto]**

This item allows you to enable or disable RM address hashing.

Configuration options: [Enabled] [Disabled] [Auto]

### **SPD Read Optimization [Auto]**

This item allows you to enable or disable SPD Read Optimization, if set to **[Enabled]**, SPD reads are skipped for Reserved fields and most of upper 256 Bytes. If set to **[Disabled]**, read all 512 SPD Bytes.

Configuration options: [Enabled] [Disabled] [Auto]

## **Memory MBIST**

### **MBIST Enable [Disabled]**

This item allows you to enable or disable Memory MBIST.

Configuration options: [Enabled] [Disabled]



---

The following items appear only when **MBIST Enable** is set to **[Enabled]**.

---

### **MBIST Test Mode [Auto]**

This item allows you to select the MBIST Test Mode - Interface Mode (Tests Single and Multiple CS transactions and Basic Connectivity) or Data Eye Mode (Measures Voltage vs. Timing).

Configuration options: [Interface Mode] [Data Eye Mode] [Both] [Auto]

### **MBIST Aggressors [Auto]**

This item allows you to enable or disable Memory Aggressor test.

Configuration options: [Enabled] [Disabled] [Auto]

### **MBIST Per Bit Slave Die Reporting [Auto]**

Reports 2D Data Eye Results in ABL Log for each DQ, Chipselect, and Channel.

Configuration options: [Enabled] [Disabled] [Auto]

## **Data Eye**

### **Pattern Select [PRBS]**

Configuration options: [PRBS] [SS0] [Both]

### **Pattern Length [3]**

This token helps to determine the pattern length. The possible options are N=3...12.

Configuration options: [3] - [9]

### **Aggressor Channel [1 Aggressor Channel]**

This helps read the aggressors channels. If set to **[Enabled]**, you can read from one or more than one aggressor channel. The default is set to **[Disabled]**.

Configuration options: [Disabled] [1 Aggressor Channel] [3 Aggressor Channels] [7 Aggressor Channels]

### **Aggressor Static Lane Control [Disabled]**

Configuration options: [Disabled] [Enabled]



---

The following items appear only when **Aggressor Static Lane Control** is set to **[Enabled]**.

---

#### **Aggressor Static Lane Select Upper 32 bits [0]**

Static Lane Select for Upper 32 bits. The bit mask represents the bits to be read.

Configuration options: [0] - [99999999]

#### **Aggressor Static Lane Select Lower 32 bits [0]**

Static Lane Select for Lower 32 bits. The bit mask represents the bits to be read.

Configuration options: [0] - [99999999]

#### **Aggressor Static Lane Select ECC [0]**

Static Lane Select for ECC Lanes. The bit mask represents the bits to be read.

Configuration options: [0] - [9]

#### **Aggressor Static Lane Value [0]**

Configuration options: [0] - [9]

#### **Target Static Lane Control [Disabled]**

Configuration options: [Disabled] [Enabled]



---

The following items appear only when **Target Static Lane Control** is set to **[Enabled]**.

---

#### **Target Static Lane Select Upper 32 bits [0]**

Static Lane Select for Upper 32 bits. The bit mask represents the bits to be read.

Configuration options: [0] - [99999999]

#### **Target Static Lane Select Lower 32 bits [0]**

Static Lane Select for Lower 32 bits. The bit mask represents the bits to be read.

Configuration options: [0] - [99999999]

#### **Target Static Lane Select ECC [0]**

Static Lane Select for ECC Lanes. The bit mask represents the bits to be read.

Configuration options: [0] - [9]

#### **Target Static Lane Value [0]**

Configuration options: [0] - [9]

#### **Data Eye Type [Worst Case Margin Only]**

This option determines which results are expected to be captured for Data Eye. Supported options are 1D Voltage Sweep, 1D Timing Sweep, 2D Full Data Eye and Worst Case Margin only.

Configuration options: [1D Voltage Sweep] [1D Timing Sweep] [2D Full Data Eye] [Worst Case Margin Only]

### **Worst Case Margin Granularity [Per Chip Select]**

Configuration options: [Per Chip Select] [Per Nibble]

### **Read Voltage Sweep Step Size [2]**

This option determines the step size for Read Data Eye voltage sweep.

Configuration options: [1] [2] [4]

### **Read Timing Sweep Step Size [1]**

This option supports step size for Read Data Eye.

Configuration options: [1] [2] [4]

### **Write Voltage Sweep Step Size [2]**

This option determines the step size for write Data Eye voltage sweep.

Configuration options: [1] [2] [4]

### **Write Timing Sweep Step Size [1]**

This option supports step size for write Data Eye.

Configuration options: [1] [2] [4]

## **4.11.4 NBIO Common Options**

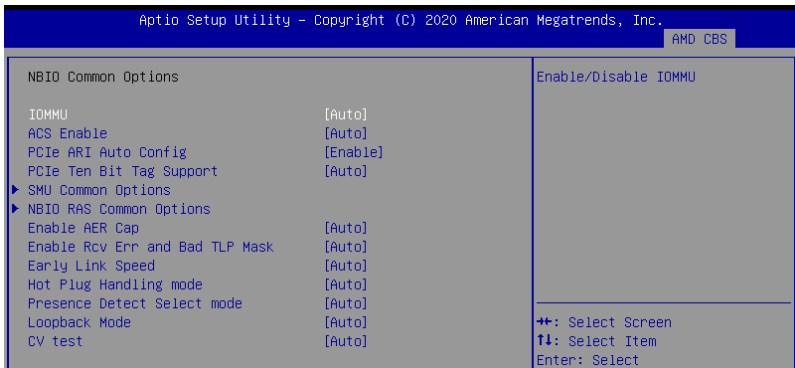

### **IOMMU [Auto]**

This item allows you to enable or disable IOMMU.

Configuration options: [Disabled] [Enabled] [Auto]



The following item appears only when **Enable AER Cap** is set to **[Auto]** or **[Enabled]**.

### **ACS Enable [Auto]**

Configuration options: [Disable] [Enable] [Auto]

### **PCIe ARI Auto Config [Enable]**

This item allows you to enable or disable the PCIe ARI Auto Detect.

Configuration options: [Disable] [Enable]





---

The following item appears only when **PCIe ARI Auto Config** is set to **[Disable]**.

---

### **PCIe ARI Support [Auto]**

This item enables Alternative Routing-ID Interpretation.

Configuration options: [Disable] [Enable] [Auto]

### **PCIe Ten Bit Tag Support [Auto]**

This item enables PCIe ten bit tags for supported devices.

Configuration options: [Disable] [Enable] [Auto]

## **SMU Common Options**

### **Determinism Control [Auto]**

[Auto] Use the fused Determinism.

[Manual] User can set customized Determinism.



---

The following item appears only when **Determinism Control** is set to **[Manual]**.

---

### **Determinism Slider [Auto]**

Configuration options: [Auto] [Power] [Performance]

### **cTDP Control [Manual]**

[Auto] Use the fused TDP.

[Manual] User can set customized TDP.



---

The following item appears only when you set **cTDP Control** to **[Manual]**.

---

### **cTDP [240]**

This item allows you to customize cTDP.

### **Power Package Limit Control [Manual]**

[Auto] Use the fused PPT.

[Manual] User can set customized PPT.



---

The following item appears only when you set **Power Package Limit Control** to **[Manual]**.

---

### **Power Package Limit [240]**

This item allows you to customize PPT.

### **APBDIS [Auto]**

Configuration options: [0] [1] [Auto]

### **DF Cstates [Auto]**

Configuration options: [Disabled] [Enabled] [Auto]

### **CPPC [Auto]**

Configuration options: [Disabled] [Enabled] [Auto]

### **HSMP Support [Auto]**

This item allows you to enable or disable HSMP support.

Configuration options: [Disabled] [Enabled] [Auto]

### **Diagnostic Mode [Auto]**

This item allows you to enable or disable Diag mode.  
Configuration options: [Disabled] [Enabled] [Auto]

### **DLWM Support [Auto]**

This item allows you to enable or disable DLWM support.  
Configuration options: [Disabled] [Enabled] [Auto]

### **BoostFmaxEn [Auto]**

[Auto] Use the default Fmax.  
[Manual] User can set the boost Fmax.



---

The following item appears only when **BoostFmaxEn** is set to **[Manual]**.

---

### **BoostFmax [0]**

This item allows you to specify the boost Fmax frequency limit to apply to all cores (MHz).

## **NBIO RAS Common Options**

### **NBIO RAS Global Control [Auto]**

Configuration options: [Auto] [Manual]

### **NBIO RAS Control [MCA]**

Configuration options: [Disabled] [MCA] [Legacy]

### **Egress Poison Severity High [30011]**

Each bit set to 1 enables HIGH severity on the associated IOHC egress port. A bit of 0 indicates LOW severity.

### **Egress Poison Severity Low [4]**

Each bit set to 1 enables HIGH severity on the associated IOHC egress port. A bit of 0 indicates LOW severity.

### **NBIO SyncFlood Generation [Auto]**

This value may be used to mask SyncFlood caused by NBIO RAS options. When set to TRUE, SyncFlood from NBIO is masked. When set to FALSE, NBIO is capable of generating SyncFlood.

Configuration options: [Disabled] [Enabled] [Auto]

### **NBIO SyncFlood Reporting [Disabled]**

This value may be used to enable SyncFlood reporting to APML. When set to TRUE, SyncFlood will be reported to APML. When set to FALSE, the reporting will be disabled.

Configuration options: [Disabled] [Enabled]

### **Egress Poison Mask High [ffffff]**

These set the enable mask for masking of errors logged in EGRESS\_POISON\_STATUS. For each bit set to 1, errors are masked. For each bit set to 0, errors trigger response actions.

### **Egress Poison Mask Low [ffffffb]**

These set the enable mask for masking of errors logged in EGRESS\_POISON\_STATUS. For each bit set to 1, errors are masked. For each bit set to 0, errors trigger response actions.

### **Uncorrected Converted to Poison Enable Mask High [30000]**

These set the enable mask for masking of uncorrectable parity errors on internal arrays. For each bit set to 1, a system fatal error event is triggered for UCP errors on arrays associated with that egress port. For each bit set to 0, errors are masked.

### **Uncorrected Converted to Poison Enable Mask Low [4]**

These set the enable mask for masking of uncorrectable parity errors on internal arrays. For each bit set to 1, a system fatal error event is triggered for UCP errors on arrays associated with that egress port. For each bit set to 0, errors are masked.

### **System Hub Watchdog Timer [a28]**

This value specifies the timer interval of the SYSHUB Watchdog Timer in milliseconds.

### **SLink Read Response OK [Disabled]**

This value specifies whether SLINK read response errors are converted to an Okay response. When this value is set to TRUE, read response errors are converted to Okay responses with data of all FFs. When set to FALSE, read response errors are not converted.

Configuration options: [Disabled] [Enabled]

### **SLink Read Response Error Handling [Log Errors in MCA]**

This value specifies whether SLINK write response errors are converted to an Okay response. When this value is set to 0, write response errors will be logged in the MCA. When set to 1, write response errors will trigger an MCOMMIT error. When this value is set to 2, write response errors are converted.

Configuration options: [Enabled] [Trigger MCOMMIT Error] [Log Errors in MCA]

### **Log Poison Data from SLINK [Disabled]**

This value specifies whether poison data propagated from SLINK will generate a deferred error. When this value is set to TRUE, deferred errors are enabled. When set to FALSE, errors are not generated.

Configuration options: [Disabled] [Enabled]

### **PCIe Aer Reporting Mechanism [Auto]**

This value selects the method of reporting AER errors from PCI Express. A value of 0 indicates that the hardware will report the error through MCA. A value of 1 allows OS First handling of the errors through generation of a system control interrupt (SCI). A value of 2 allows Firmware First handling of the errors through generation of a system control interrupt (SCI).

Configuration options: [Firmware First] [OS First] [MCA] [Auto]

### **Edpc Control [Disabled]**

Configuration options: [Disabled] [Enabled] [Auto]

### **NBIO Poison Consumption [Auto]**

Configuration options: [Disabled] [Enabled] [Auto]

### **Sync Flood on PCIe Fatal Error [Auto]**

Configuration options: [Auto] [True] [False]

## **Enable AER Cap [Auto]**

This item allows you to enable or disable Advanced Error Reporting Capability.

Configuration options: [Enable] [Disabled] [Auto]

### Enable Rcv Err and Bad TLP Mask [Auto]

This item allows you to enable masking of receiver error and bad TLP at Gen4 x2.  
Configuration options: [Disabled] [Enabled] [Auto]

### Early Link Speed [Auto]

This item allows you to set Early Link Speed.  
Configuration options: [Auto] [Gen1] [Gen2]

### Hot Plug Handling mode [Auto]

This item allows you to control the Hot Plug Handling mode.  
Configuration options: [A0 Mode] [OS First (No Error Handling)] [OS First (Error Handling - Not Implemented)] [Firmware First (Not Implemented)] [Auto]

### Presence Detect Select mode [Auto]

This item allows you to control the Presence Detect Select mode.  
Configuration options: [OR] [AND] [Auto]

### Loopback Mode [Auto]

This item allows you to enable or disable PCIe Loopback mode.  
Configuration options: [Disabled] [Enabled] [Auto]

### CV test [Auto]

Set this item to **[Enabled]** to support running PCIECV tool.  
Configuration options: [Disabled] [Enabled] [Auto]

## 4.11.5 NTB Common Options

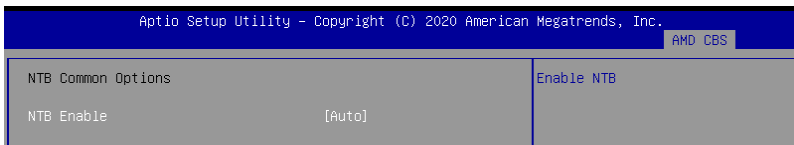

### NTB Enable [Auto]

This item allows you to enable NTB.  
Configuration options: [Auto] [Enable]



The following item appears only when **NTB Enable** is set to **[Enable]**.

### NTB Location [Auto]

Configuration options: [Auto] [Socket0-Die0] [Socket0-Die1] [Socket0-Die2] [Socket0-Die3] [Socket1-Die0] [Socket1-Die1] [Socket1-Die2] [Socket1-Die3]

### NTB active on PCIeCore [Auto]

Configuration options: [Auto] [Core0] [Core1]

### NTB Mode [Auto]

This item allows you to select the NTB Mode (Core 0, Port 0)  
Configuration options: [NTB Disabled] [NTB Primary] [NTB Secondary] [NTB Random] [Auto]

## Link Speed [Auto]

This item allows you to select the Link Speed for NTB Mode (Core 0, Port 0).  
Configuration options: [Max Speed] [Gen 1] [Gen 2] [Gen 3] [Auto] [Gen 4]

## 4.12 Event Logs menu

The Event Logs menu items allow you to change the event log settings and view the system event logs.

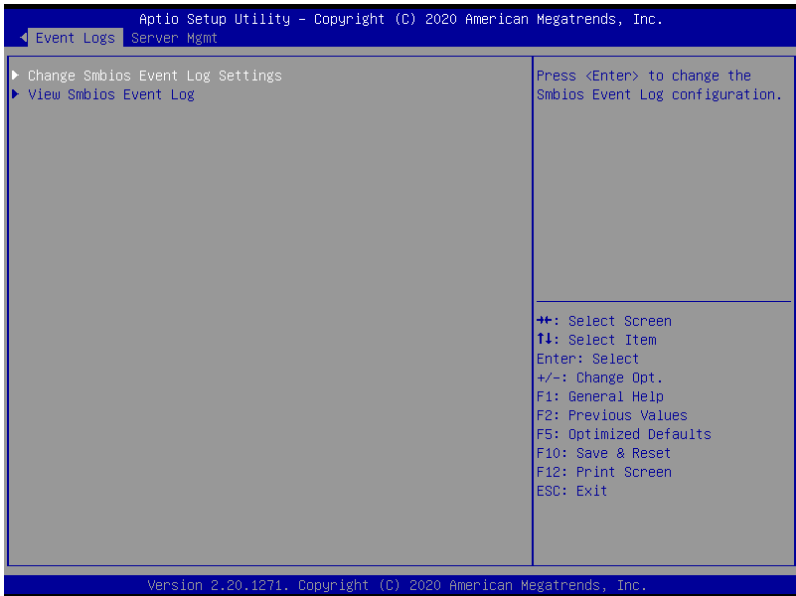

### 4.12.1 Change Smbios Event Log Settings

Press <Enter> to change the Smbios Event Log configuration.



All values changed here do not take effect until computer is restarted.

#### Enabling/Disabling Options

##### Smbios Event Log [Enabled]

Change this to enable or disable all features of Smbios Event Logging during boot.  
Configuration options: [Disabled] [Enabled]



---

The following item appears only when **Smbios Event Log** is set to **[Enabled]**.

---

## Erasing Settings

### Erase Event Log [No]

Choose options for erasing Smbios Event Log. Erasing is done prior to any logging activation during reset.

Configuration options: [No] [Yes, Next reset] [Yes, Every reset]

## Smbios Event Log Standard Settings

### Log System Boot Event [Disabled]

This option allows you to enable or disable logging System boot event.

Configuration options: [Disabled] [Enabled]

### MECI [1]

The Multiple Event Count Increment is the occurrences of a duplicate event that must pass before the multiple-event counter of log entry is updated. The values range from 1 to 255.

### METW [60]

The Multiple Event Time Window is the number of minutes which must pass between duplicate log entries which utilize a multiple-event counter. The values range from 0 to 99 minutes.

## Custom Options

### Log EFI Status Code [Enabled]

This option allows you to enable or disable logging of the EFI Status Codes.

Configuration options: [Disabled] [Enabled]



---

The following item appears only when **Log EFI Status Code** is set to **[Enabled]**.

---

### Convert EFI Status Codes to Standard Smbios Type [Disabled]

This option allows you to enable or disable converting of EFI Status Codes to Standard Smbios Type (Not all may be translated).

Configuration options: [Disabled] [Enabled]

## 4.12.2 View Smbios Event Log

Press <Enter> to view all smbios event logs.

## 4.13 Server Mgmt menu

The Server Management menu displays the server management status and allows you to change the settings.

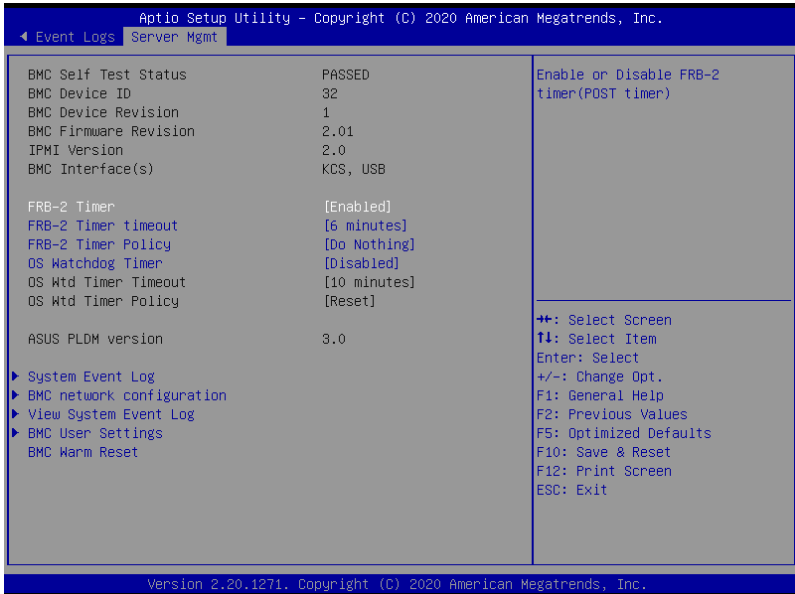

### FRB-2 Timer [Enabled]

Allows you to enable or disable FRB-2 timer (POST timer).

Configuration options: [Disabled] [Enabled]



The following items appear only when **FRB-2 Timer** is set to **[Enabled]**.

### FRB-2 Timer timeout [6 minutes]

Allows you to select the FRB-2 Timer Expiration value.

Configuration options: [3 minutes] [4 minutes] [5 minutes] [6 minutes]

### FRB-2 Timer Policy [Do Nothing]

Allows you to select the how the system should respond in FRB-2 Timer expires.

Configuration options: [Do Nothing] [Reset] [Power Down] [Power Cycle]

### OS Watchdog Timer [Disabled]

This item allows you to start a BIOS timer which can only be shut off by Intel Management Software after the OS loads.

Configuration options: [Disabled] [Enabled]



---

The following items appear only when **OS Watchdog Timer** is set to **[Enabled]**.

---

### **OS Wtd Timer Timeout [10 minutes]**

Allows you to configure the length for the OS Boot Watchdog Timer.

Configuration options: [5 minutes] [10 minutes] [15 minutes] [20 minutes]

### **OS Wtd Timer Policy [Reset]**

This item allows you to configure how the system should respond if the OS Boot Watchdog Timer expires.

Configuration options: [Do Nothing] [Reset] [Power Down] [Power Cycle]

## **System Event Log**

Allows you to change the SEL event log configuration.

### **Erase SEL [No]**

Allows you to choose options for erasing SEL.

Configuration options: [No] [Yes, On next reset] [Yes, On every reset]

### **Custom EFI Logging Options**

#### **Log EFI Status Codes [Error code]**

Allows you to select which codes to log.

Configuration options: [Disabled] [Both] [Error code] [Progress code]

## **BMC network configuration**

The sub-items in this configuration allow you to configure the BMC network parameters.

### **Configure IPv4 support**

#### **DM\_LAN1**

##### **IPV4 Support [Enabled]**

Allows you to enable or disable LAN1 IPv4 Support.

Configuration options: [Disabled] [Enabled]

#### **Shared LAN**

##### **Configuration Address source [Previous State]**

This item allows you to configure LAN channel parameters statically or dynamically (by BIOS or BMC). Unspecified option will not modify any BMC network parameters during BIOS phase.

Configuration options: [Previous State] [Static] [DynamicBmcDhcp]

### **Configure IPv6 support**

#### **DM\_LAN1**

##### **IPV6 Support [Enabled]**

Allows you to enable or disable LAN1 IPv6 Support.

Configuration options: [Disabled] [Enabled]





---

The following item appears only when **IPV6 Support** is set to **[Enabled]**.

---

#### **Configuration Address source [Previous State]**

This item allows you to configure LAN channel parameters statistically or dynamically (by BIOS or BMC). Unspecified option will not modify any BMC network parameters during BIOS phase.

Configuration options: [Previous State] [Static] [DynamicBmcDhcp]

#### **Shared LAN**

#### **IPV6 Support [Enabled]**

Allows you to enable or disable LAN2 IPV6 Support.

Configuration options: [Disabled] [Enabled]



---

The following items appear only when **IPV6 Support** is set to **[Enabled]**.

---

#### **Configuration Address source [Previous State]**

This item allows you to configure LAN channel parameters statistically or dynamically (by BIOS or BMC). Unspecified option will not modify any BMC network parameters during BIOS phase.

Configuration options: [Previous State] [Static] [DynamicBmcDhcp]

### **View System Event Log**

This item allows you to view the system event log records.

### **BMC User Settings**

The sub-items in this configuration allow you to add, delete, or change BMC user settings.

### **BMC Warm Reset**

Press <Enter> to perform a BMC Warm Reset.



# Driver Installation

# 5

This chapter provides instructions for installing the necessary drivers for different system components.

## 5.1 Running the Support DVD

The support DVD that is bundled with your motherboard contains drivers, management applications, and utilities that you can install to maximize the features of your motherboard.



---

The contents of the support DVD are subject to change at any time without notice. Visit the ASUS website ([www.asus.com](http://www.asus.com)) for the latest updates on software and utilities.

---

The main screen of the Support DVD contains the following tabs:

1. Drivers - Shows the available device drivers that the system detects.
2. Utilities - Displays the software applications and utilities that the motherboard supports.
3. Manual - Provides the link to the user guide(s).



---

You need an internet browser installed in your OS to view the User Guide.

---

4. Contact - Displays the ASUS contact information, e-mail addresses, and useful links if you need more information or technical support for your motherboard.

# Appendix

This appendix includes additional information that you may refer to when configuring the motherboard.

# KRPG-U8 block diagram

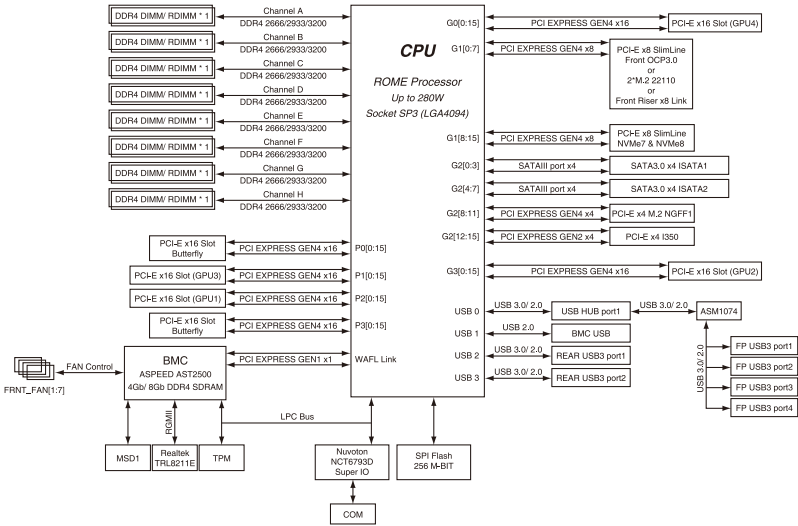

## Notices

### Federal Communications Commission Statement

This device complies with Part 15 of the FCC Rules. Operation is subject to the following two conditions:

- This device may not cause harmful interference.
- This device must accept any interference received including interference that may cause undesired operation.

This equipment has been tested and found to comply with the limits for a Class A digital device, pursuant to part 15 of the FCC Rules. These limits are designed to provide reasonable protection against harmful interference when the equipment is operated in a commercial environment. This equipment generates, uses, and can radiate radio frequency energy and, if not installed and used in accordance with the instruction manual, may cause harmful interference to radio communications. Operation of this equipment in a residential area is likely to cause harmful interference in which case the user will be required to correct the interference at his own expense.



---

The use of shielded cables for connection of the monitor to the graphics card is required to assure compliance with FCC regulations. Changes or modifications to this unit not expressly approved by the party responsible for compliance could void the user's authority to operate this equipment.

---

### Compliance Statement of Innovation, Science and Economic Development Canada (ISED)

This device complies with Innovation, Science and Economic Development Canada licence exempt RSS standard(s). Operation is subject to the following two conditions: (1) this device may not cause interference, and (2) this device must accept any interference, including interference that may cause undesired operation of the device.

CAN ICES-003(A)/NMB-003(A)

### Déclaration de conformité de Innovation, Sciences et Développement économique Canada (ISED)

Le présent appareil est conforme aux CNR d'Innovation, Sciences et Développement économique Canada applicables aux appareils radio exempts de licence. L'exploitation est autorisée aux deux conditions suivantes : (1) l'appareil ne doit pas produire de brouillage, et (2) l'utilisateur de l'appareil doit accepter tout brouillage radioélectrique subi, même si le brouillage est susceptible d'en compromettre le fonctionnement.

CAN ICES-003(A)/NMB-003(A)

### Japan statement notice

This product cannot be directly connected to the Internet (including public wireless LAN) of a telecom carrier (mobile network companies, landline network companies, Internet providers, etc.). When connecting this product to the Internet, be sure to connect it through a router or switch.

## Japan JATE

本製品は電気通信事業者（移動通信会社、固定通信会社、インターネットプロバイダ等）の通信回線（公衆無線LANを含む）に直接接続することができません。本製品をインターネットに接続する場合は、必ずルータ等を経由し接続してください。」等が考えられる。

## Australia statement notice

From 1 January 2012 updated warranties apply to all ASUS products, consistent with the Australian Consumer Law. For the latest product warranty details please visit <https://www.asus.com/support/>. Our goods come with guarantees that cannot be excluded under the Australian Consumer Law. You are entitled to a replacement or refund for a major failure and compensation for any other reasonably foreseeable loss or damage. You are also entitled to have the goods repaired or replaced if the goods fail to be of acceptable quality and the failure does not amount to a major failure.

If you require assistance please call ASUS Customer Service 1300 2787 88 or visit us at <https://www.asus.com/support/>.



DO NOT throw the motherboard in municipal waste. This product has been designed to enable proper reuse of parts and recycling. This symbol of the crossed out wheeled bin indicates that the product (electrical and electronic equipment) should not be placed in municipal waste. Check local regulations for disposal of electronic products.



DO NOT throw the mercury-containing button cell battery in municipal waste. This symbol of the crossed out wheeled bin indicates that the battery should not be placed in municipal waste.

## Declaration of compliance for product environmental regulation

ASUS follows the green design concept to design and manufacture our products, and makes sure that each stage of the product life cycle of ASUS product is in line with global environmental regulations. In addition, ASUS disclose the relevant information based on regulation requirements.

Please refer to <http://csr.asus.com/Compliance.htm> for information disclosure based on regulation requirements ASUS is complied with:

### EU REACH and Article 33

Complying with the REACH (Registration, Evaluation, Authorization, and Restriction of Chemicals) regulatory framework, we publish the chemical substances in our products at ASUS REACH website at <http://csr.asus.com/english/REACH.htm>.

### EU RoHS

This product complies with the EU RoHS Directive. For more details, see <http://csr.asus.com/english/article.aspx?id=35>

### Japan JIS-C-0950 Material Declarations

Information on Japan RoHS (JIS-C-0950) chemical disclosures is available on <http://csr.asus.com/english/article.aspx?id=19>



## India RoHS

This product complies with the "India E-Waste (Management) Rules, 2016" and prohibits use of lead, mercury, hexavalent chromium, polybrominated biphenyls (PBBs) and polybrominated diphenyl ethers (PBDEs) in concentrations exceeding 0.1% by weight in homogenous materials and 0.01% by weight in homogenous materials for cadmium, except for the exemptions listed in Schedule II of the Rule.

## Vietnam RoHS

ASUS products sold in Vietnam, on or after September 23, 2011, meet the requirements of the Vietnam Circular 30/2011/TT-BCT.

Các sản phẩm ASUS bán tại Việt Nam, vào ngày 23 tháng 9 năm 2011 trở về sau, đều phải đáp ứng các yêu cầu của Thông tư 30/2011/TT-BCT của Việt Nam.

## Türkiye RoHS

AEEE Yönetmeliğine Uygundur

## ASUS Recycling/Takeback Services

ASUS recycling and takeback programs come from our commitment to the highest standards for protecting our environment. We believe in providing solutions for you to be able to responsibly recycle our products, batteries, other components as well as the packaging materials. Please go to <http://csr.asus.com/english/Takeback.htm> for detailed recycling information in different regions.

## Ecodesign Directive

European Union announced a framework for the setting of ecodesign requirements for energy-related products (2009/125/EC). Specific Implementing Measures are aimed at improving environmental performance of specific products or across multiple product types. ASUS provides product information on the CSR website. The further information could be found at <https://csr.asus.com/english/article.aspx?id=1555>.

## Safety Precautions

Accessories that came with this product have been designed and verified for the use in connection with this product. Never use accessories for other products to prevent the risk of electric shock or fire.

## 安全上のご注意

付属品は当該専用品です。他の機器には使用しないでください。機器の破損もしくは、火災や感電の原因となることがあります。

## Service and Support

Visit our multi-language website at <https://www.asus.com/support/>



