



RT-AX56U

Wireless-AX1800 Dual Band WiFi 6 Router

Wireless-AX1800 雙頻WiFi 6 無線路由器

Wireless-AX1800 雙頻WiFi 6 無線路由器

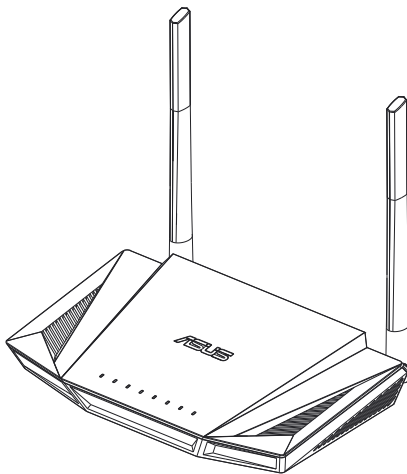

Quick Start Guide/ 快速使用指南

A15721 / First Edition / August 2019

Table of contents

Package contents	3
A quick look at RT-AX56U	3
Position your wireless router	4
Preparing your modem	5
Setting up your RT-AX56U	6
A. Wired connection	6
B. Wireless connection	6
FAQ	8
Networks Global Hotline Information	55

This QSG contains these languages:

English, 繁體中文, 简体中文, Bahasa Indonesia, 한국어,
Bahasa Melayu, ไทย, Tiếng Việt

Package contents

- ☑ RT-AX56U Wireless Router
- ☑ Network cable (RJ-45)
- ☑ AC adapter
- ☑ Quick Start Guide

A quick look at RT-AX56U

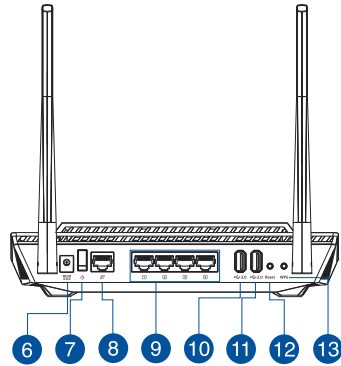
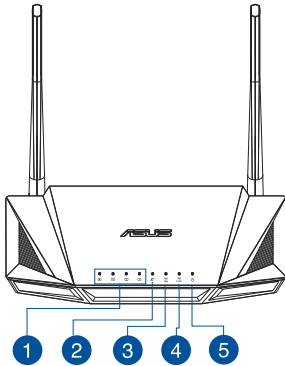

① LAN 1~4 LEDs	⑧ WAN (Internet) port
② WAN (Internet) LED	⑨ LAN 1 ~ 4 ports
③ 5GHz LED	⑩ USB 3.1 port
④ 2.4GHz LED	⑪ USB 2.0 port
⑤ Power LED	⑫ Reset button
⑥ Power (DC-IN) port	⑬ WPS button
⑦ Power switch	

Position your wireless router

For optimal wireless transmission between the wireless router and connected wireless devices, ensure that you:

- Place the wireless router in a centralized area for a maximum wireless coverage for the network devices.
- Keep the wireless router away from metal obstructions and away from direct sunlight.
- Keep the wireless router away from 802.11g or 20MHz only Wi-Fi devices, 2.4GHz computer peripherals, Bluetooth devices, cordless phones, transformers, heavy-duty motors, fluorescent lights, microwave ovens, refrigerators, and other industrial equipment to prevent signal interference or loss.
- Always update to the latest firmware. Visit the ASUS website at <http://www.asus.com> to get the latest firmware updates.
- To ensure the best wireless signal, orient the four non-detachable antennas as shown in the drawing below.

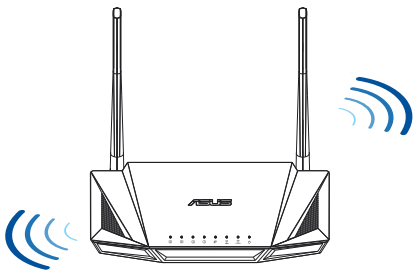

NOTES:

- Use only the adapter that came with your package. Using other adapters may damage the device.

• Specifications:

DC Power adapter	DC Output: +12V with 2A current		
Operating Temperature	0~40°C	Storage	0~70°C
Operating Humidity	50~90%	Storage	20~90%

Preparing your modem

1. **Unplug the power cable/DSL modem. If it has a battery backup, remove the battery.**

NOTE: If you are using DSL for Internet, you will need your username/password from your Internet Service Provider (ISP) to properly configure the router.

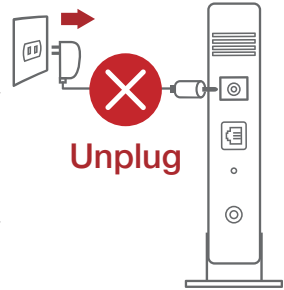

2. **Connect your modem to the router with the bundled network cable.**

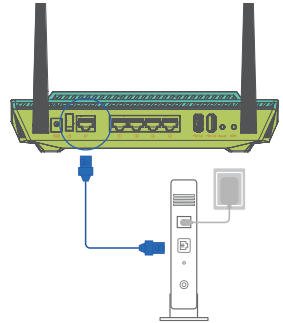

3. **Power on your cable/DSL modem.**
4. **Check your cable/DSL modem LED lights to ensure the connection is active.**

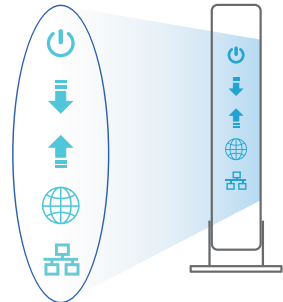

Setting up your RT-AX56U

You can set up your router via wired or wireless connection.

A. Wired connection

1. Plug your router into a power outlet and power it on. Connect the network cable from your computer to a LAN port on your router.

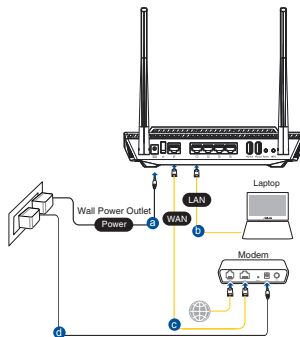

2. The web GUI launches automatically when you open a web browser. If it does not auto-launch, enter <http://router.asus.com>.
3. Set up a password for your router to prevent unauthorized access.

Login Information Setup

Change the router password to prevent unauthorized access to your ASUS wireless router.

Router Login Name:

New Password:

Retype Password: Show password

B. Wireless connection

1. Plug your router into a power outlet and power it on.

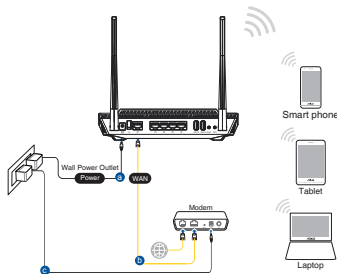

2. **Connect to the network with SSID shown on the product label on the back side of the router. For better network security, change to a unique SSID and assign a password.**



Wi-Fi Name (SSID): ASUS_XX

- * **XX** refers to the last two digits of the MAC address. You can find it on the label on the back of your router.

3. **You can choose either the web GUI or ASUS Router app to set up your router.**

- a. **Web GUI Setup**

- **Once connected, the web GUI launches automatically when you open a web browser. If it does not auto-launch, enter <http://router.asus.com>.**
- **Set up a password for your router to prevent unauthorized access.**

A screenshot of the 'Login Information Setup' page. The title is 'Login Information Setup'. Below the title, it says 'Change the router password to prevent unauthorized access to your ASUS wireless router.' There are three input fields: 'Router Login Name' with the value 'admin', 'New Password', and 'Retype Password'. To the right of the 'Retype Password' field is a checkbox labeled 'Show password'.

b. App Setup

Download ASUS Router App to set up your router via your mobile devices.

- Turn on Wi-Fi on your mobile devices and connect to your router's network.
- Follow ASUS Router App setup instructions to complete the setup.



ASUS
Router



Remembering your wireless router settings

- Remember your wireless settings as you complete the router setup.

Router Name:	Password:
2.4 GHz network SSID:	Password:
5GHz network SSID:	Password:

FAQ

1. Where can I find more information about the wireless router?

- Online FAQ site: <https://www.asus.com/support/faq>
- Technical support site: <https://www.asus.com/support>
- Customer hotline: refer to the Support Hotline section in this Quick Start Guide
- You can get the user manual online at <https://www.asus.com/support>

產品包裝內容

- ☑ RT-AX56U 無線路由器
- ☑ 電源變壓器
- ☑ RJ-45 網路線
- ☑ 快速使用指南

認識您的無線路由器

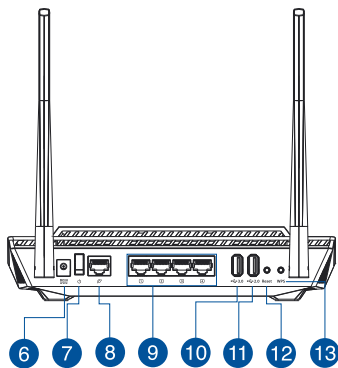
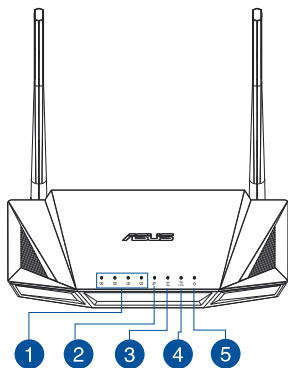

1 LAN 1-4 指示燈	8 WAN (網際網路) 連接埠
2 WAN (網際網路) 指示燈	9 LAN 1 ~ 4 網路連接埠
3 5GHz 指示燈	10 USB 3.1 連接埠
4 2.4GHz 指示燈	11 USB 2.0 連接埠
5 電源指示燈	12 重置按鈕
6 電源 (DC-IN) 連接埠	13 WPS 按鈕
7 電源開關	

放置您的路由器

為獲得無線路由器與所連線的網路裝置之間傳送最佳無線訊號，請確認以下幾點：

- 建議將路由器放置在中心區域，以獲得最佳無線訊號覆蓋範圍。
- 請勿將裝置放在靠近金屬物品與陽光直射的地方。
- 請遠離其它 802.11g 或 20MHz Wi-Fi 裝置、2.4GHz 電腦周邊裝置、藍牙裝置、無線室內電話、傳送器、重型發動機、日光燈、微波爐、電冰箱與其他工業裝置，以防止訊號干擾或減損。
- 請經常更新至最新版本韌體。您可以登入華碩官網 <https://www.asus.com/tw/> 獲得最新韌體。
- 請依據下圖所示擺放路由器上的四根可拆式天線以獲得最佳無線訊號覆蓋範圍。

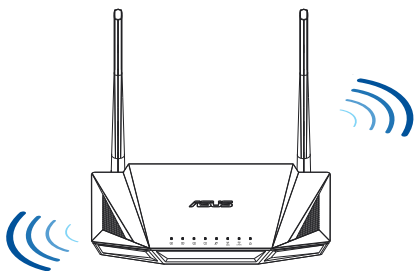

注意：

- 請僅使用包裝中的變壓器。使用其他種類變壓器可能會造成裝置損毀。
- 規格：

直流電源變壓器	DC 輸出： +12V 電壓，支援最大 2A 電流		
運作溫度	0-40° C	儲存溫度	0-70° C
運作濕度	50-90%	儲存溫度	20-90%

準備數據機

1. 拔除您的電纜 / DSL 數據機電源，若數據機內含備用電池，請移除電池。

注意：若您使用 DSL 連線網際網路，需要向您的網路服務供應商（ISP）取得登入名稱 / 密碼，以正確設定您的無線路由器。

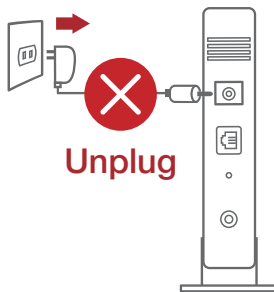

2. 使用隨附的網路線連接您的數據機與無線路由器。

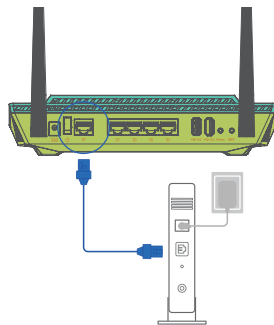

3. 開啟您的纜線 / DSL數據機。
4. 查看數據機的 LED 指示燈以確認連線是否已準備就緒。

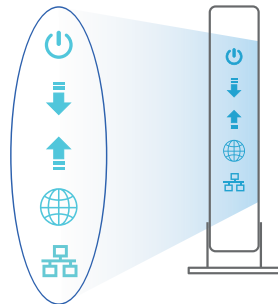

設定您的路由器

您可以透過有線或無線兩種方式設定您的無線路由器。

A. 有線連線

1. 將您的無線路由器與電源相連並開機。用網路線將您的電腦與無線路由器的 LAN 連接埠相連。

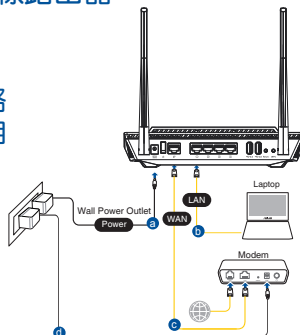

2. 當您開啟網頁瀏覽器時，網頁設定介面會自動出現。若沒有出現，請在網址欄中輸入 <http://router.asus.com>。
3. 為無線路由器設定密碼以阻止未經授權的存取。

Login Information Setup

Change the router password to prevent unauthorized access to your ASUS wireless router.

Router Login Name	<input type="text" value="admin"/>
New Password	<input type="password"/>
Retype Password	<input type="password"/> <input type="checkbox"/> Show password

B. 無線連線

1. 將您的無線路由器與電源相連並開機。

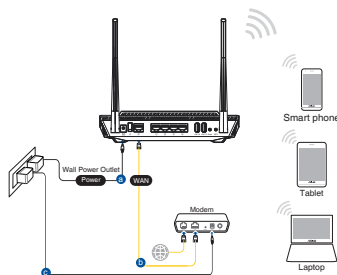

2. 連接到無線路由器後側標籤上註明的網路名稱（SSID）。為確保最佳的網路安全性，請更改預設的 SSID 和密碼。



Wi-Fi 名稱 (SSID) : ASUS_XX

- * XX 代表 2.4GHz MAC 位址的最後兩位數，您可以在路由器背部的貼紙上找到。

3. 您可以在網頁瀏覽器或 ASUS Router App 中設定您的路由器。

- a. 透過網頁瀏覽器設定

- 連線網路後，當您開啟網頁瀏覽器時，網頁設定介面會自動出現。若沒有出現，請在網址欄中輸入 <http://router.asus.com>。
- 為無線路由器設定密碼以阻止未經授權的存取。

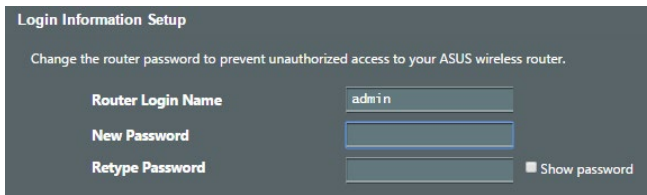

b. 透過 App 設定

透過行動裝置下載 ASUS Router App 以設定您的路由器。

- 開啟行動裝置的 Wi-Fi 並連線至無線路由器的網路。
- 遵照 ASUS Router App 設定嚮導完成路由器設定。



ASUS Router



記住無線路由器的設定

- 完成無線路由器的設定後，請記住您的無線設定。

路由器登入名稱：	密碼：
2.4GHz 網路 SSID:	密碼：
5GHz 網路 SSID:	密碼：

FAQ

1. 哪裡可以找到更多的無線路由器資訊？

- 線上 FAQ 網址：<https://www.asus.com/tw/support>
- 技術支援網址：<https://www.asus.com/tw/support>
- 客戶服務熱線：請參閱此快速使用指南的支援熱線（Hotline）
- 您可至 <https://www.asus.com/tw/support> 下載使用手冊

产品包装内容

- ☑ RT-AX56U 无线路由器
- ☑ 电源适配器
- ☑ RJ-45 网线
- ☑ 快速使用指南

认识您的无线路由器

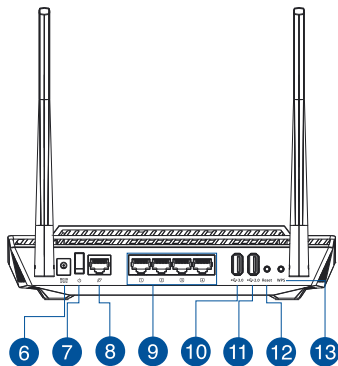
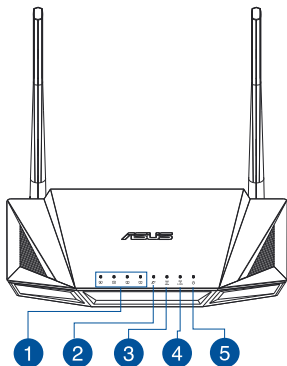

① LAN 1~4 指示灯	⑧ WAN（互联网）接口
② WAN（互联网）指示灯	⑨ LAN 1 ~ 4 接口
③ 5GHz 指示灯	⑩ USB 3.1 接口
④ 2.4GHz 指示灯	⑪ USB 2.0 接口
⑤ 电源指示灯	⑫ 复位按钮
⑥ 电源（DC-IN）插孔	⑬ WPS 按钮
⑦ 电源开关	

放置您的路由器

为获得无线路由器与所连接的网络设备之间的最佳无线传输信号，请确认以下几点：

- 建议将路由器放置在中心区域，以获得最佳无线信号覆盖。
- 请勿将设备放在靠近金属物品与阳光直射的地方。
- 请远离其它 802.11g 或 20MHz Wi-Fi 设备、2.4GHz 电脑外围设备、蓝牙设备、无线室内电话、传送器、重型发动机、日光灯、微波炉、电冰箱与其他工业设备，以防止信号干扰或丢失。
- 请经常更新至最新版本固件。您可以登录华硕官网 <https://www.asus.com.cn> 获得最新固件。
- 请按照下图所示摆放路由器上的两根可拆式天线以获得最佳无线信号覆盖。

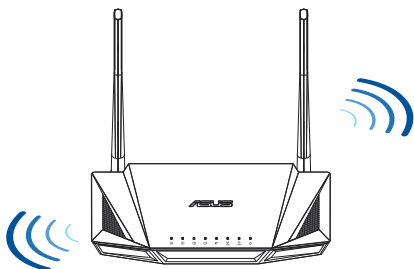

注意：

- 仅使用包装物中的电源适配器。使用其他类型的电源适配器可能会对您的设备造成损坏。
- 规格：

直流电源适配器	DC 输出：+12V 电压，支持最大 2A 电流		
运行温度	0~40° C	保存温度	0~70° C
运行湿度	50~90%	保存湿度	20~90%

准备调制解调器

1. 拔除您的线缆 / DSL 调制解调器电源，若调制解调器内含备用电池，请移除电池。

注意：若您使用 PPPoE 连接互联网，需要向您的网络服务供应商（ISP）取得登录帐号 / 密码，以正确设置您的无线路由器。

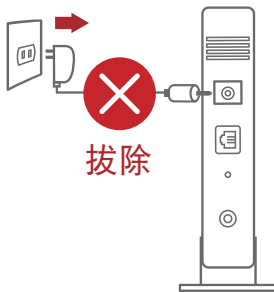

2. 使用随附的网线连接您的调制解调器与无线路由器。

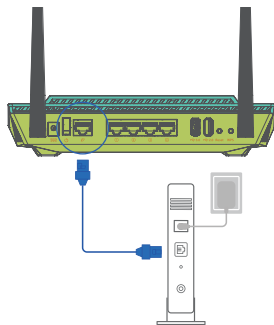

3. 开启您的线缆 / DSL 调制解调器。
4. 检查线缆 / DSL 调制解调器上的指示灯，确认已连接至网络。

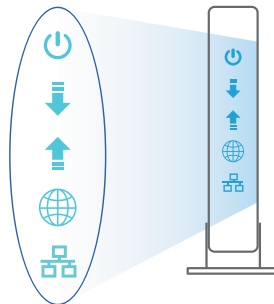

设置您的路由器

您可以通过有线或无线两种方式设置您的无线路由器。

A. 有线连接

1. 将您的路由器连接电源并开机。将网线两端分别插入电脑的 RJ45 网络插孔与路由器的 LAN 接口。

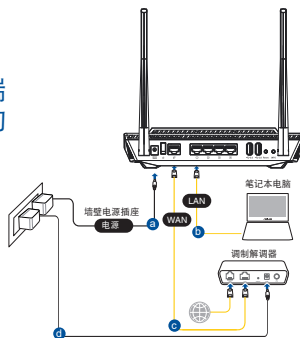

2. 当您开启网页浏览器后，会自动进入网页图形用户界面（Web GUI）。若此界面未自动弹出，请手动输入 <http://router.asus.com>。
3. 为无线路由器设置密码以阻止未经授权的访问。

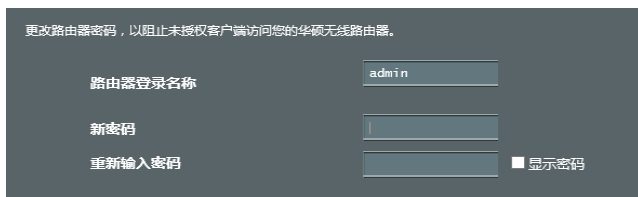

B. 无线连接

1. 将您的路由器连接电源并开机。

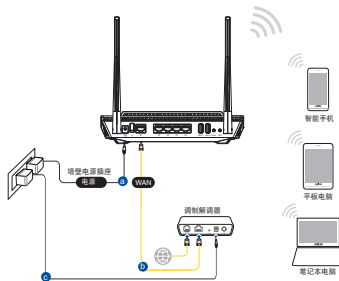

2. 连接到无线路由器后侧标签上注明的网络名称（SSID）。为确保更佳的网络安全性，请更改默认的 SSID 和密码。



Wi-Fi 名称 (SSID) : ASUS_XX

- * XX 是 2.4GHz MAC 地址的后两位数字。您可在机器后侧的贴纸上找到。

3. 您可以在网页浏览器或 ASUS Router App 中设置您的路由器。

- a. 通过网页浏览器设置

- 当您开启网页浏览器后，会自动进入网页图形用户界面（Web GUI）。若此界面未自动弹出，请手动输入 <http://router.asus.com>。
- 为无线路由器设置密码以阻止未经授权的访问。

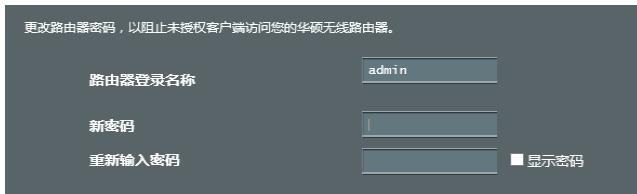

b. 通过 App 设置

通过移动设备下载 ASUS Router App 以设置您的路由器。

- 开启移动设备的 Wi-Fi 并连接至无线路由器的网络。
- 遵照 ASUS Router App 设置向导完成路由器设置。

注意：请使用浏览器中的扫码工具扫描右侧 Android 设备的二维码。



ASUS
Router



记住无线路由器的设置

- 完成无线路由器的设置后，请记住您的无线设置。

路由器登录名称：	密码：
2.4 GHz 网络 SSID：	密码：
5GHz 网络 SSID：	密码：

常见问题与解答 (FAQ)

1. 哪里可以找到更多的无线路由器信息？

- 在线 FAQ 网址：<https://www.asus.com.cn/support>
- 技术支持网址：<https://www.asus.com.cn/support>
- 客户服务热线：请参阅此快速使用指南的支持热线
- 您可至 <https://www.asus.com.cn/support/> 下载用户手册



注意：微信扫描右侧二维码，获取更多服务咨询及在线客服咨询。
核准编号在产品名牌位置标识。

Isi kemasan

- ☑ Router Nirkabel RT-AX56U
- ☑ Kabel jaringan (RJ-45)
- ☑ Adaptor AC
- ☑ Panduan Ringkas

Tampilan RT-AX56U

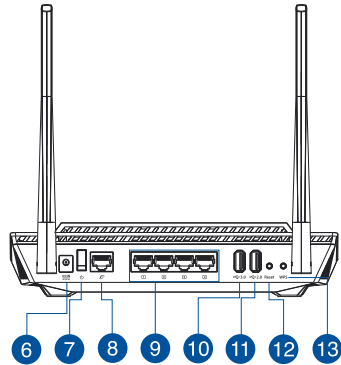
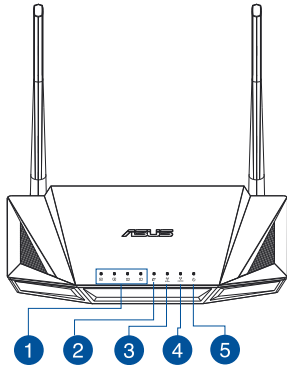

1 LEDs LAN 1~4	8 Port WAN (Internet)
2 LED WAN (Internet)	9 Port LAN 1~4
3 LED 5GHz	10 Port USB 3.1
4 LED 2,4GHz	11 Port USB 2.0
5 LED Daya	12 Tombol atur ulang
6 Port daya (DC-IN)	13 Tombol WPS
7 Tombol daya	

Mengatur posisi router nirkabel Anda.

Untuk transmisi sinyal nirkabel terbaik antara router nirkabel dan perangkat jaringan yang tersambung, pastikan Anda:

- Menempatkan router nirkabel di area tengah agar jangkauan nirkabel maksimum untuk perangkat jaringan.
- Tidak menghalangi perangkat dengan benda logam dan menjauhkan dari sinar matahari langsung.
- Menjauhkan perangkat dari perangkat Wi-Fi 802.11g atau hanya 20 MHz, periferal komputer 2,4 GHz, perangkat Bluetooth, telepon nirkabel, trafo, mesin berat, cahaya neon, oven microwave, lemari es, dan peralatan industri lainnya untuk mencegah interferensi atau hilangnya sinyal.
- Selalu memperbarui ke firmware terkini. Untuk mendapatkan pembaruan firmware terkini, kunjungi situs Web ASUS <http://www.asus.com>.
- Untuk memastikan sinyal nirkabel terbaik, arahkan empat antena yang tidak dapat dilepas seperti yang ditunjukkan gambar di bawah.

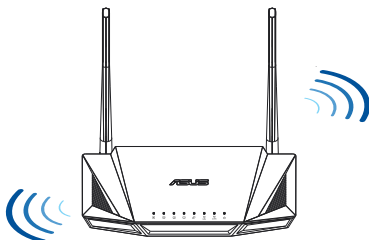

CATATAN:

- Gunakan hanya adaptor yang diberikan dalam paket. Menggunakan adaptor lain dapat merusak perangkat.
- **Spesifikasi:**

Adaptor daya DC	Output DC: +12 V dengan arus maks. 2 A		
Suhu Pengoperasian	0~40°C	Penyimpanan	0~70°C
Kelembaban Pengoperasian	50~90%	Penyimpanan	20~90%

Menyiapkan modem

1. Lepaskan modem DSL/kabel dari catu daya. Jika ada cadangan baterai, keluarkan baterai.

CATATAN: Jika menggunakan DSL untuk Internet, Anda memerlukan nama pengguna/sandi dari Penyedia Layanan Internet (ISP) untuk mengkonfigurasi router dengan benar.

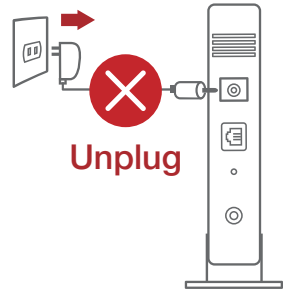

2. Sambungkan modem ke router dengan kabel jaringan yang tersedia.

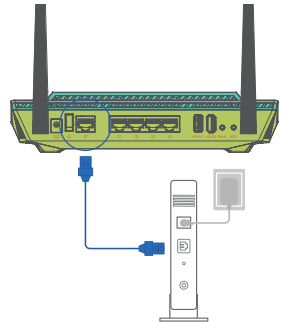

3. Hidupkan modem kabel/DSL.
4. Periksa lampu LED modem kabel/DSL untuk memastikan sambungan sudah aktif.

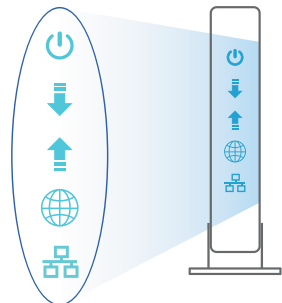

Mengkonfigurasi RT-AX56U

Anda dapat mengkonfigurasi router melalui sambungan berkabel atau nirkabel.

A. Sambungan berkabel:

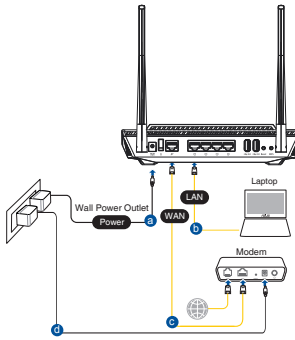
1. **Sambungkan router ke stopkontak dan hidupkan. Sambungkan kabel jaringan dari komputer ke port LAN pada router.**
- 
2. **GUI web akan secara otomatis dijalankan saat Anda membuka browser web. Jika tidak secara otomatis dijalankan, buka <http://router.asus.com>.**
 3. **Konfigurasikan sandi router untuk mencegah akses yang tidak sah.**

Login Information Setup

Change the router password to prevent unauthorized access to your ASUS wireless router.

Router Login Name	<input type="text" value="admin"/>	
New Password	<input type="password"/>	
Retype Password	<input type="password"/>	<input type="checkbox"/> Show password

B. Sambungan Nirkabel

1. **Sambungkan router ke stopkontak dan hidupkan.**

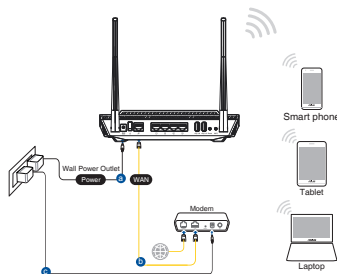

2. **Sambungkan ke nama jaringan (SSID) yang tertera pada label produk, di bagian belakang router. Untuk keamanan jaringan yang lebih baik, ubah menjadi SSID unik, lalu tetapkan sandi.**



Nama Wi-Fi (SSID): ASUS_XX

- * **XX** mengacu ke 2 angka terakhir pada alamat MAC. Anda dapat menemukannya pada label di bagian belakang RT-AX56U.

3. **Anda dapat memilih aplikasi GUI web atau ASUS Router untuk mengatur router.**

a. **Konfigurasi GUI Web**

- **GUI web akan secara otomatis dijalankan saat Anda membuka browser web. Jika tidak secara otomatis dijalankan, buka <http://router.asus.com>.**
- **Konfigurasikan sandi router untuk mencegah akses yang tidak sah.**

Login Information Setup

Change the router password to prevent unauthorized access to your ASUS wireless router.

Router Login Name	<input type="text" value="admin"/>
New Password	<input type="password"/>
Retype Password	<input type="password"/> <input type="checkbox"/> Show password

b. Konfigurasi Aplikasi

Untuk mengkonfigurasi router melalui perangkat bergerak, download Aplikasi ASUS Router.

- Aktifkan Wi-Fi di perangkat bergerak, lalu sambungkan ke jaringan RT-AX56U.
- Ikuti petunjuk pada Aplikasi ASUS Router untuk menyelesaikan konfigurasi.



ASUS
Router



Menyimpan pengaturan router nirkabel

- Ingat pengaturan nirkabel setelah Anda menyelesaikan konfigurasi router.

Nama Router:	Sandi:
SSID jaringan 2,4 GHz:	Sandi:
SSID jaringan 5 GHz:	Sandi:

Tanya Jawab

1. Di mana saya dapat memperoleh informasi lengkap tentang router nirkabel?
 - Situs tanya jawab online: <https://www.asus.com/support/faq>
 - Situs Dukungan Teknis: <https://www.asus.com/support>
 - Hotline Pelanggan: Lihat Hotline Dukungan dalam Panduan Tambahan
 - Anda dapat memperoleh panduan pengguna secara online di <https://www.asus.com/support>

패키지 내용

- ☑ RT-AX56U 무선 라우터
- ☑ AC 어댑터
- ☑ 네트워크 케이블 (RJ-45)
- ☑ 빠른 시작 가이드

빠른 보기

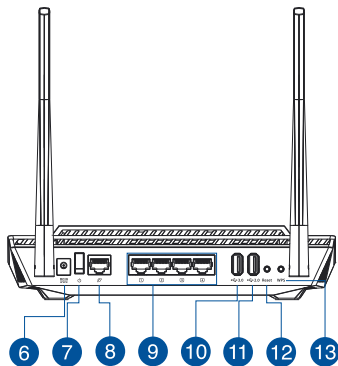
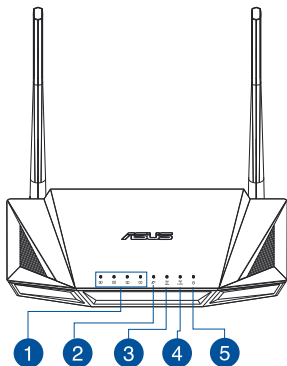

1 LAN 1~4 LED	8 WAN(인터넷) 포트
2 WAN(인터넷) LED	9 LAN 1~4 포트
3 5GHz LED	10 USB 3.1 포트
4 2.4GHz LED	11 USB 2.0 포트
5 전원 LED	12 리셋 버튼
6 전원 (DC-IN) 포트	13 WPS 버튼
7 전원 스위치	

무선 라우터의 위치

무선 라우터와 연결된 무선 장치들 사이의 최적의 무선 전송을 위해, 다음을 확인하십시오:

- 네트워크 장치를 최대한으로 무선 커버 할 수 있는 중심 지역에 무선 라우터를 위치시키십시오.
- 무선 라우터를 금속 장애물 및 직사 광선으로 부터 멀리 위치시킵니다.
- 802.11g 또는 20MHz Wi-Fi 장치, 2.4GHz 컴퓨터 주변, 블루투스 장치, 무선 전화기, 변압기, 중장비 모터, 형광등, 전자레인지, 냉장고, 신호 간섭 또는 손실을 막는 산업 장비들로 부터 무선 라우터를 멀리 위치시킵니다.
- 항상 최신 펌웨어로 업데이트 하십시오. ASUS 웹사이트 <http://www.asus.com> 에서 최신 펌웨어를 얻을 수 있습니다.
- 최상의 무선 신호를 보장하기 위해, 네 개의 비탈착식 안테나를 아래의 그림과 같이 위치시키십시오.

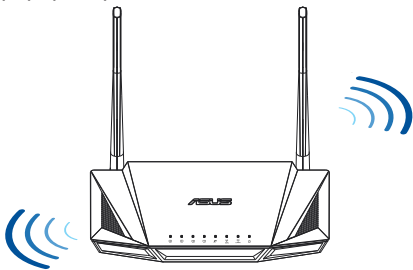

참고:

- 함께 제공된 어댑터만 사용하십시오. 다른 어댑터를 사용하면 장치가 파손될 수 있습니다.

• 사양:

DC 전원 어댑터	DC 출력: 최대 2A 전류에서 +12V		
작동 온도	0~40°C	보관	0~70°C
작동 습도	50~90%	보관	20~90%

모뎀 준비하기

1. 전원 케이블/DSL 모뎀을 분리합니다. 배터리 백업이 있는 경우 배터리를 제거합니다.

참고: 인터넷용 DSL를 사용하는 경우 라우터를 올바르게 구성하려면 인터넷 서비스 제공자(ISP)에서 제공한 사용자 이름/비밀번호가 필요합니다.

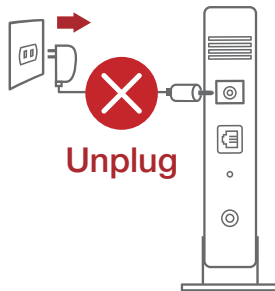

2. 번들로 제공된 네트워크 케이블을 사용하여 모뎀을 라우터에 연결합니다.

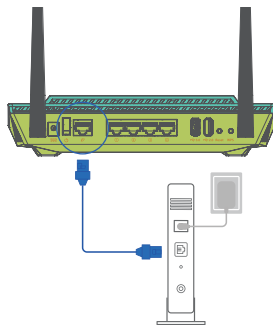

3. 케이블/DSL 모뎀의 전원을 켭니다.
4. 케이블/DSL 모뎀 LED 표시등을 보고 연결이 활성화되었는지 확인합니다.

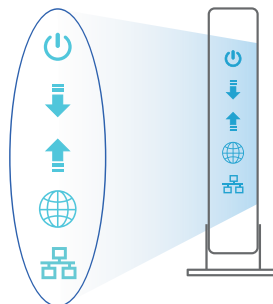

라우터 설정하기

유선 또는 무선 연결을 통해 라우터를 설정할 수 있습니다.

A. 유선 연결

1. 라우터를 전원 콘센트에 연결하고 전원을 켭니다. 네트워크 케이블을 사용하여 컴퓨터와 라우터의 LAN 포트를 연결합니다.

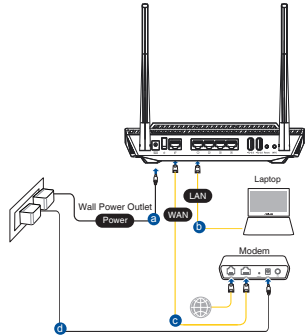

2. 웹 브라우저를 열면 웹 GUI가 자동으로 시작됩니다. 자동으로 시작되지 않으면 <http://router.asus.com> 으로 들어갑니다.
3. 무단 액세스를 방지하기 위해 라우터의 비밀번호를 설정합니다.

Login Information Setup

Change the router password to prevent unauthorized access to your ASUS wireless router.

Router Login Name	admin
New Password	<input type="password"/>
Retype Password	<input type="password"/> <input type="checkbox"/> Show password

B. 무선 모드

1. 라우터를 전원 콘센트에 연결하고 전원을 켭니다.

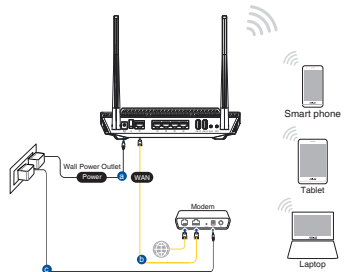

2. 라우터 뒷면의 제품 라벨에 표시된 네트워크 이름(SSID)에 연결합니다.네트워크 보안을 강화하기 위해 고유한 SSID로 변경하고 비밀번호를 지정합니다.



Wi-Fi 이름(SSID): ASUS_XX

* **XX**은(는) MAC 주소의 마지막 두 자릿수를 참조합니다. 이는 라우터 뒷면의 라벨에서 확인할 수 있습니다.

3. 웹 GUI 또는 ASUS 라우터 앱을 선택하여 라우터를 설정할 수 있습니다.

a. 웹 GUI 설정

- 연결된 경우 웹 브라우저를 열면 웹 GUI가 자동으로 시작됩니다. 자동으로 시작되지 않으면 <http://router.asus.com>으로 들어갑니다.
- 무단 액세스를 방지하기 위해 라우터의 비밀번호를 설정합니다.

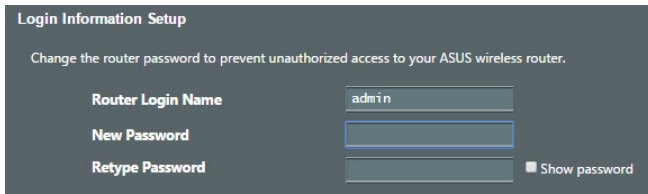

b. 앱 설정

ASUS 라우터 앱을 다운로드하여 모바일 장치를 통해 라우터를 설정합니다.

- 모바일 장치에서 Wi-Fi를 켜고 RT-AX56U 의 네트워크에 연결합니다.
- ASUS 라우터 앱 설정 지침을 따라 설정을 완료합니다.



ASUS Router



무선 라우터 설정 기억하기

- 라우터 설정을 완료할 때 무선 설정을 기억해두십시오.

라우터 이름:	비밀번호:
2.4 GHz 네트워크 SSID:	비밀번호:
5 GHz 네트워크 SSID:	비밀번호:

자주 묻는 질문 (FAQs)

1. 무선 라우터에 관한 더 자세한 정보는 어디에서 찾을 수 있습니까?
 - 온라인 FAQ 사이트: <https://www.asus.com/support/faq>
 - 기술 지원 사이트: <https://www.asus.com/support>
 - 고객 핫라인: 빠른 시작 안내서 내의 지원 핫라인을 참조하십시오.
 - <https://www.asus.com/support> 에서 온라인으로 사용 설명서를 다운로드할 수 있습니다.

Kandungan pembungkusan

- ☑ Penghala wayarles RT-AX56U
- ☑ Penyesuai AU
- ☑ Kabel rangkaian (RJ-45)
- ☑ Panduan Mula Ringkas

Melihat sebentar Lalu RT-AX56U anda

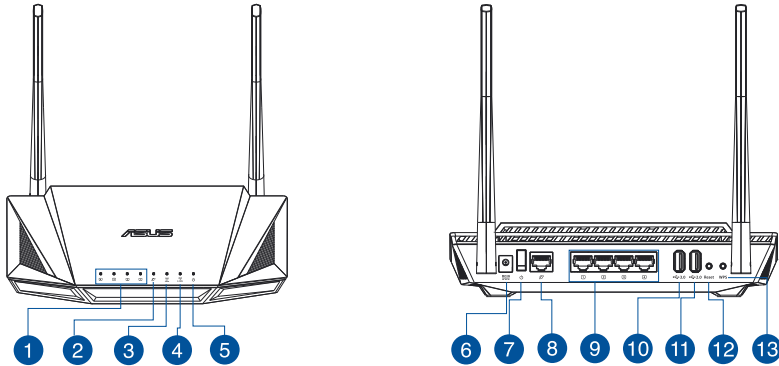

1 LAN 1~4 LEDs	8 Port WAN (Internet)
2 WAN (Internet) LED	9 Port LAN 1~4
3 LED 5GHz	10 Port USB 3.1
4 LED 2.4GHz	11 Port USB 2.0
5 LED Kuasa	12 Butang tetapkan semula
6 Port kuasa (DC-In) (AT-Masuk)	13 Butang WPS
7 Suis kuasa	

Meletakkan penghala wayarles anda

Untuk penghantaran wayarles optimum antara penghala wayarles dan peranti wayarles yang bersambung, pastikan anda:

- Letakkan penghala wayarles dalam kawasan terpusat untuk liputan wayarles maksimum untuk peranti rangkaian.
- Pastikan penghala wayarles jauh daripada penghalang logam dan jauh daripada cahaya matahari langsung.
- Pastikan penghala wayarles jauh daripada peranti Wi-Fi 802.11g atau 20MHz sahaja, 2.4GHZ persisian komputer, peranti Bluetooth, telefon kordles, pengubah, motor tugas berat, lampu kalimantang, ketuhar gelombang mikro, peti sejuk, dan peralatan industri lain untuk mengelakkan gangguan atau kehilangan isyarat.
- Sentiasa kemas kini perisian tegar terkini. Lawati tapak web ASUS di <http://www.asus.com> untuk mendapatkan kemas kini perisian tegar terkini.
- Untuk memastikan isyarat wayarles terbaik, sesuaikan 4 antena tidak boleh tanggal seperti yang ditunjukkan dalam rajah di bawah.

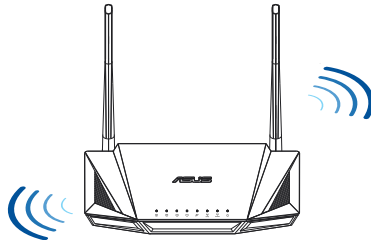

NOTA:

- Hanya guna adapter yang disertakan bersama pakej anda. Menggunakan adapter lain boleh merosakkan peranti.
- **Spesifikasi:**

Adapter Kuasa DC	Output DC: +12V dengan arus maksimum 2A		
Suhu Pengendalian	0~40°C	Penyimpanan	0~70°C
Kelembapan Operasi	50~90%	Penyimpanan	20~90%

Menyediakan modem anda

1. Cabut palam kabel kuasa/modem DSL. Jika ia mempunyai sandaran bateri, keluarkan bateri.

NOTA: Jika anda menggunakan DSL untuk Internet, anda akan memerlukan nama pengguna/kata laluan anda daripada Pembekal Perkhidmatan Internet (ISP) anda untuk mengkonfigurasi penghala dengan betul.

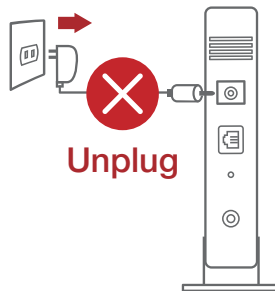

2. Sambung modem anda ke penghala dengan kabel rangkaian yang digabungkan.

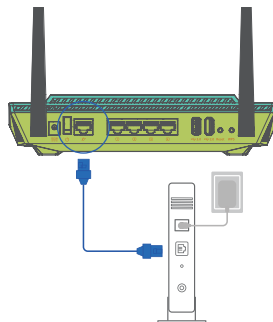

3. Hidupkan kuasa kabel/modem DSL anda.
4. Semak kabel/lampu LED modem DSL anda untuk memastikan sambungan adalah aktif.

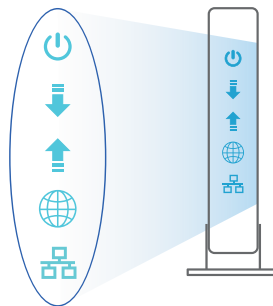

Menyediakan RT-AX56U anda

Anda boleh menyediakan penghala anda melalui sambungan berwayar atau wayarles.

A. Sambungan berwayar

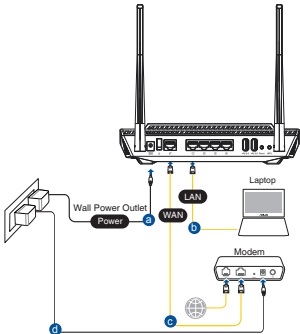
1. Pasang masuk penghala anda ke sumber kuasa dan hidupkan kuasanya. Sambungkan kabel rangkaian dari komputer anda ke port LAN pada penghala anda.
- 
2. GUI web dilancarkan secara automatik apabila anda membuka pelayar web. Jika ia tidak melakukan pelancaran auto, masuki <http://router.asus.com>.
 3. Sediakan kata laluan untuk penghala anda bagi menghalang akses yang tidak dibenarkan.

Login Information Setup

Change the router password to prevent unauthorized access to your ASUS wireless router.

Router Login Name	<input type="text" value="admin"/>	
New Password	<input type="password"/>	
Retype Password	<input type="password"/>	<input type="checkbox"/> Show password

B. Sambungan wayarles

1. Pasang masuk penghala anda ke sumber kuasa dan hidupkan kuasanya.

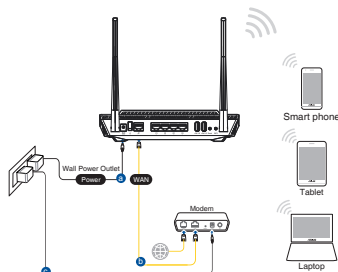

2. Sambung ke nama rangkaian (SSID) yang ditunjukkan pada label produk di bahagian belakang penghala. Untuk keselamatan rangkaian yang lebih baik, ubah ke SSID unik dan berikan kata laluan.



Nama Wi-Fi (SSID): ASUS_XX

- * **XX** merujuk pada dua digit terakhir alamat MAC Anda boleh menemuinya pada label di belakang penghala anda.

3. Anda boleh memilih sama ada GUI web atau aplikasi Penghala ASUS untuk menyediakan penghala anda.

a. Penyediaan GUI Web

- GUI web dilancarkan secara automatik apabila anda membuka pelayar web. Jika ia tidak melakukan pelancaran auto, masuki <http://router.asus.com>.
- Sediakan kata laluan untuk penghala anda bagi menghalang akses yang tidak dibenarkan.

Login Information Setup

Change the router password to prevent unauthorized access to your ASUS wireless router.

Router Login Name	<input type="text" value="admin"/>
New Password	<input type="password"/>
Retype Password	<input type="password"/> <input type="checkbox"/> Show password

b. Penyediaan Aplikasi

Muat turun Aplikasi Penghala ASUS untuk menyediakan penghala anda melalui peranti mudah alih anda.



ASUS
Router



- **Hidupkan Wi-Fi pada peranti mudah alih anda dan sambung ke rangkaian RT-AX56U anda.**
- **Ikuti arahan penyediaan Aplikasi Penghala ASUS untuk melengkapkan penyediaan.**



Mengingati tetapan penghala wayarles anda

- **Ingat tetapan wayarles anda apabila anda melengkapkan penyediaan penghala.**

Nama Penghala:	Kata Laluan:
SSID rangkaian 2.4GHz:	Kata Laluan:
SSID rangkaian 5GHz	Kata Laluan:

Soalan Lazim (FAQ)

1. Di manakah saya boleh mendapatkan maklumat lanjut mengenai penghala tanpa wayar?
 - Tapak FAQ dalam talian: <https://www.asus.com/support/faq>
 - Tapak Sokongan Teknikal: <https://www.asus.com/support>
 - Hotline Pelanggan: Rujuk Hotline Sokongan dalam Panduan Mula Pantas ini
 - Anda boleh mendapatkan manual pengguna dalam talian di <https://www.asus.com/support>

สิ่งต่างๆ ในกล่องบรรจุ

- ☑ RT-AX56U ไร้สาย เราเตอร์
- ☑ อะแดปเตอร์ AC
- ☑ สายเคเบิลเครือข่าย (RJ-45)
- ☑ คู่มือเริ่มต้นฉบับย่อ

ดูที่ RT-AX56U ของคุณอย่างรวดเร็ว

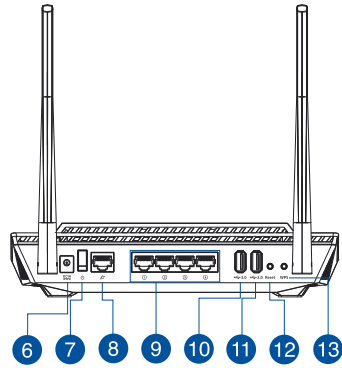
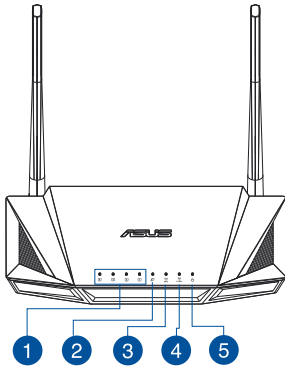

1 LEDs LAN 1~4	8 พอร์ต WAN (อินเทอร์เน็ต)
2 LED WAN (อินเทอร์เน็ต)	9 พอร์ต LAN 1~4
3 LED 5GHz	10 พอร์ต USB 3.1
4 LED 2.4GHz	11 พอร์ต USB 2.0
5 LED เพาเวอร์	12 ปุ่มรีเซ็ต
6 พอร์ตเพาเวอร์ (DC-เข้า)	13 ปุ่ม WPS
7 สวิตช์พาวเวอร์	

การวางตำแหน่งไวร์เลส เราเตอร์ของคุณ

เพื่อให้การรับส่งสัญญาณไวร์เลสระหว่างไวร์เลสเราเตอร์ และอุปกรณ์เครือข่ายที่เชื่อมต่ออยู่มีคุณภาพดีที่สุด ให้แน่ใจว่าคุณ:

- วางไวร์เลสเราเตอร์ในบริเวณศูนย์กลาง เพื่อให้ครอบคลุมพื้นที่ไวร์เลสมากที่สุดสำหรับอุปกรณ์เครือข่าย
- วางอุปกรณ์ให้ห่างจากวัตถุขวางกั้นที่เป็นโลหะ และไม่ให้อุปกรณ์ส่งแรงแดดโดยตรง
- วางอุปกรณ์ให้ห่างจากอุปกรณ์ Wi-Fi 802.11g หรือ 20MHz, อุปกรณ์ต่อพ่วงคอมพิวเตอร์ 2.4GHz, อุปกรณ์บลูทูธ, โทรศัพท์ไวร์เลส, หมอแปลง, หมอเตอรืพลังงานสูง, แสงฟลูออเรสเซนต์, เต้าไม่โคโรนาฟ, ตู้เย็น และอุปกรณ์อุตสาหกรรมอื่นๆ เพื่อป้องกันสัญญาณรบกวน หรือสัญญาณสูญหาย
- อัปเดตไปเป็นเฟิร์มแวร์ล่าสุดเสมอ เยี่ยมชมเว็บไซต์ ASUS ที่ <http://www.asus.com> เพื่อรับอัปเดตเฟิร์มแวร์ล่าสุด
- เพื่อให้มั่นใจถึงสัญญาณไวร์เลสที่ดีที่สุด ให้ปรับทิศทางเสาอากาศที่สามารถถอดได้ 4 อัน ในลักษณะที่แสดงในภาพด้านล่าง

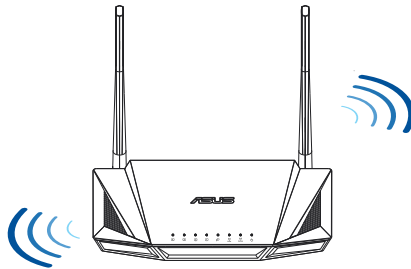

หมายเหตุ

- ใช้เฉพาะอะแดปเตอร์ที่มาพร้อมกับแพ็คเกจของคุณเท่านั้น การใช้อะแดปเตอร์อื่นอาจทำให้อุปกรณ์เสียหาย
- ข้อมูลจำเพาะ:

อะแดปเตอร์เพาเวอร์ DC	เอาต์พุต DC: +12V โดยมีกระแสสูงสุด 2A		
อุณหภูมิขณะทำงาน	0~40°C	ขณะเก็บรักษา	0~70°C
ความชื้นขณะทำงาน	50~90%	ขณะเก็บรักษา	20~90%

การจัดเตรียมโมเด็มของคุณ

1. ถอดสายไฟ/โมเด็ม DSL หากมีแบตเตอรี่สำรอง ให้ถอดแบตเตอรี่ออก

หมายเหตุ: หากคุณใช้ DSL สำหรับอินเทอร์เน็ต คุณต้องมีชื่อผู้ใช้/รหัสผ่านจากผู้ให้บริการอินเทอร์เน็ต (ISP) เพื่อกำหนดค่าเราเตอร์ อย่างถูกต้อง

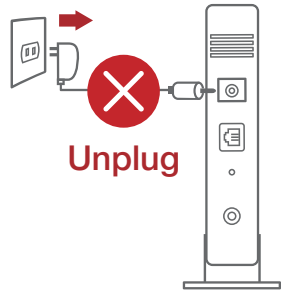

2. เชื่อมต่อโมเด็มของคุณเข้ากับเราเตอร์ด้วยสายเคเบิล เครือข่ายที่ใหม่มา

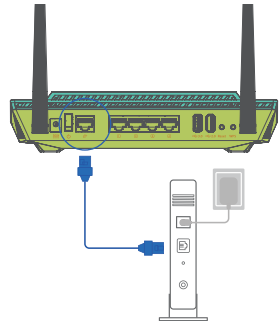

3. เปิดเคเบิล/โมเด็ม DSL

4. ตรวจสอบไฟ, LED ของเคเบิล/โมเด็ม DSL เพื่อให้แน่ใจว่าการเชื่อมต่อทำงานอยู่

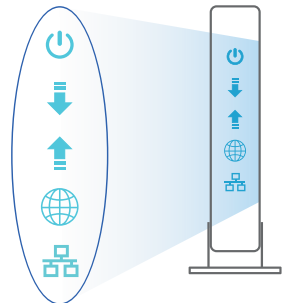

การตั้งค่า RT-AX56U

คุณสามารถตั้งค่าเราเตอร์ผ่านการเชื่อมต่อแบบมีสายหรือไร้สาย:

A. การเชื่อมต่อแบบมีสาย:

1. เสียบเราเตอร์เข้ากับเต้าเสียบและ เปิดเครื่อง เชื่อมต่อสายเคเบิลเครือข่ายจากคอมพิวเตอร์ไปยัง พอร์ต LAN บนเราเตอร์ของคุณ

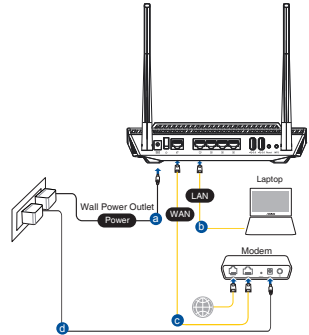

2. เว็บ GUI จะเปิดใช้งานโดยอัตโนมัติเมื่อคุณเปิดเว็บเบราว์เซอร์ หากไม่เปิดใช้งานโดยอัตโนมัติ เข้าไปที่ <http://router.asus.com>
3. ตั้งค่ารหัสผ่านสำหรับเราเตอร์ของคุณเพื่อความปลอดภัยจากการเข้าถึงที่ไม่ได้รับ อนุญาต

Login Information Setup

Change the router password to prevent unauthorized access to your ASUS wireless router.

Router Login Name	admin
New Password	<input type="password"/>
Retype Password	<input type="password"/>

Show password

B. การเชื่อมต่อไร้สาย

1. เสียบเราเตอร์เข้ากับเต้าเสียบและ เปิดเครื่อง

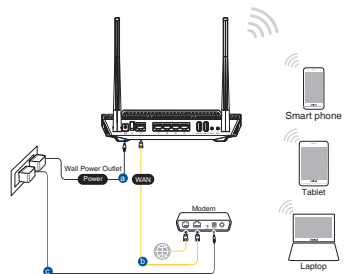

2. เชื่อมต่อกับชื่อเครือข่าย (SSID) ที่แสดงบนฉลากผลิตภัณฑ์ที่ด้านหลังของเราเตอร์ เพื่อการรักษาความปลอดภัยของเครือข่ายที่ดีกว่า เปลี่ยนเป็น SSID ที่มีลักษณะเฉพาะและกำหนดรหัสผ่าน



ชื่อ Wi-Fi (SSID): ASUS_XX

* XX หมายถึงตัวเลขสองหลักสุดท้ายของ MAC แอดเดรส คุณสามารถค้นหาได้บนฉลากด้านหลังของ RT-AX56U

3. คุณสามารถเลือกเว็บ GUI หรือแอป ASUS Router เพื่อตั้งค่าเราเตอร์ของคุณ
 a. ตั้งค่าผ่านเว็บ GUI

- เมื่อเชื่อมต่อแล้ว เว็บ GUI จะเปิดใช้งานโดยอัตโนมัติเมื่อคุณเปิดเว็บเบราว์เซอร์ หากไม่เปิดใช้งานโดยอัตโนมัติ เข้าไปที่ <http://router.asus.com>
- ตั้งค่ารหัสผ่านสำหรับเราเตอร์ของคุณเพื่อความปลอดภัยจากการเข้าถึงที่ไม่ได้รับอนุญาต

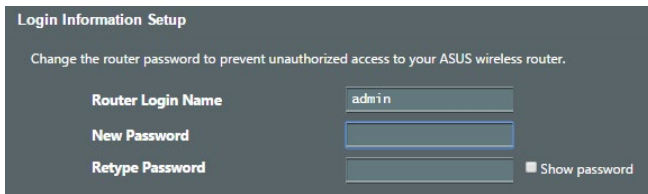

b. ตั้งค่าผ่านแอป

ดาวน์โหลดแอป ASUS Router เพื่อตั้งค่าเราเตอร์ผ่านอุปกรณ์เคลื่อนที่



ASUS
Router



- เปิด Wi-Fi บนอุปกรณ์เคลื่อนที่ของคุณ และเชื่อมต่อกับเครือข่ายของ RT-AX56U
- ปฏิบัติตามคำแนะนำการตั้งค่าแอป ASUS Router เพื่อทำการตั้งค่าให้สมบูรณ์



การจดจำการตั้งค่าเราเตอร์ไร้สาย

- จดจำการตั้งค่าไร้สายของคุณเมื่อคุณเสร็จสิ้นการตั้งค่าเราเตอร์

ชื่อเราเตอร์:	รหัสผ่าน:
SSID ของเครือข่าย 2.4 GHz:	รหัสผ่าน:
SSID ของเครือข่าย 5G Hz:	รหัสผ่าน:

คำถามที่ถามบ่อย

1. สามารถหาข้อมูลเพิ่มเติมเกี่ยวกับเราเตอร์แบบไร้สายได้จากที่ไหน?
 - เว็บไซต์ FAQ ออนไลน์: <https://www.asus.com/support/faq>
 - เว็บไซต์สนับสนุนด้านเทคนิค: <https://www.asus.com/support>
 - สายด่วนบริการลูกค้า: ดูที่หัวข้อสายด่วนบริการในคู่มือเริ่มต้นอย่างรวดเร็ว
 - คุณสามารถขอรับคู่มือผู้ใช้ออนไลน์ได้ที่ <https://www.asus.com/support>

Hàng hóa đóng gói

- ☑ Router không dây RT-AX56U
- ☑ Adapter AC (điện xoay chiều)
- ☑ Cáp mạng (RJ-45)
- ☑ Hướng dẫn khởi động nhanh

Xem nhanh

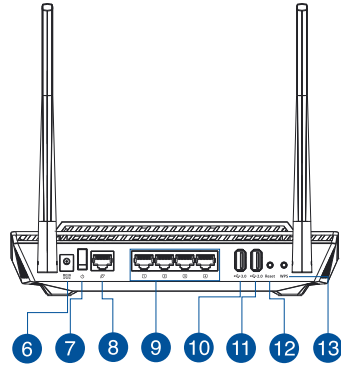
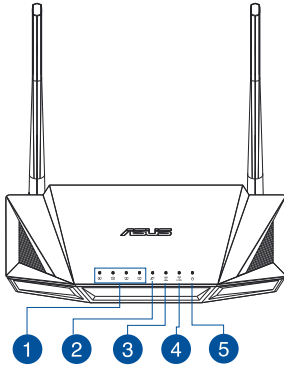

1 Đèn LED LAN 1~4	8 Cổng WAN (Internet)
2 Đèn LED WAN (Internet)	9 Cổng LAN 1~4
3 Đèn LED 5GHz	10 Cổng USB 3.1
4 Đèn LED 2,4GHz	11 Cổng USB 2.0
5 Đèn LED nguồn	12 Nút khởi động lại
6 Cổng nguồn (DC-IN)	13 Nút WPS
7 Nút bật/tắt nguồn	

Bố trí router không dây

Để truyền tín hiệu không dây tối ưu giữa router không dây và các thiết bị mạng vừa kết nối, đảm bảo bạn:

- Đặt router không dây ở khu vực trung tâm có phạm vi phủ sóng không dây tối đa dành cho các thiết bị mạng.
- Đặt thiết bị cách xa các vật cản kim loại và ánh sáng mặt trời trực tiếp.
- Đặt thiết bị cách xa các thiết bị Wi-Fi 802.11g hoặc 20MHz, thiết bị ngoại vi máy tính 2,4GHz, thiết bị Bluetooth, điện thoại di động, máy biến áp, động cơ công suất cao, ánh sáng huỳnh quang, lò vi sóng, tủ lạnh và các thiết bị công nghiệp khác để phòng tránh nhiễu hoặc mất tín hiệu.
- Luôn cập nhật bằng firmware mới nhất. Truy cập trang web ASUS tại <http://www.asus.com> để tải các cập nhật firmware mới nhất.
- Để đảm bảo tín hiệu không dây tối ưu, hãy định hướng 4 ăngten có không thể tháo rời như minh họa trong bảng vẽ dưới đây.

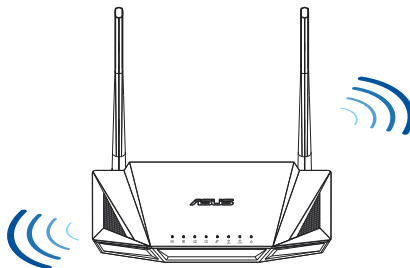

LƯU Ý:

- Chỉ nên sử dụng adapter kèm theo gói sản phẩm của bạn. Sử dụng các adapter khác có thể làm hỏng thiết bị.
- **Thông số kỹ thuật:**

Adapter nguồn DC	Đầu ra DC: +12V với dòng điện tối đa 2A		
Nhiệt độ hoạt động	0~40°C	Bảo quản	0~70°C
Độ ẩm hoạt động	50~90%	Bảo quản	20~90%

Chuẩn bị modem

1. **Ngắt cáp nguồn/modem DSL. Nếu có dùng pin dự phòng, hãy tháo pin ra.**

LƯU Ý: Nếu đang sử dụng DSL cho internet, bạn cần có tên người dùng/mật khẩu từ Nhà cung cấp Dịch vụ Internet (ISP) để thiết lập router đúng cách.

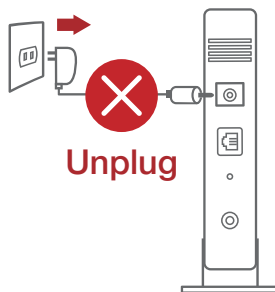

2. **Kết nối modem của bạn với router bằng cáp mạng kèm theo.**

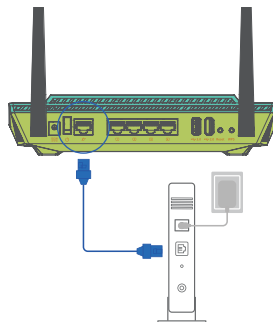

3. **Bật nguồn modem cáp/DSL.**
4. **Kiểm tra ánh sáng đèn LED trên modem cáp/DSL để đảm bảo kết nối đang hoạt động.**

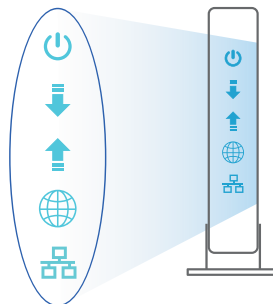

Thiết lập RT-AX56U

Để thiết lập router qua kết nối có dây hoặc không dây.

A. Kết nối có dây

1. Cắm router vào ổ cắm điện và bật nguồn router. Cắm cáp mạng từ máy tính vào cổng LAN trên router.
2. GUI (giao diện người dùng đồ họa) web sẽ tự động bật lên khi bạn mở trình duyệt web. Nếu nó không tự động bật lên, hãy nhập <http://router.asus.com>.
3. Thiết lập mật khẩu cho router để ngăn chặn truy cập trái phép.

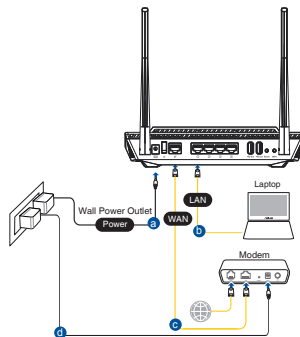

Login Information Setup

Change the router password to prevent unauthorized access to your ASUS wireless router.

Router Login Name

New Password

Retype Password

 Show password

B. Kết nối mạng không dây

1. Cắm router vào ổ cắm điện và bật nguồn router.

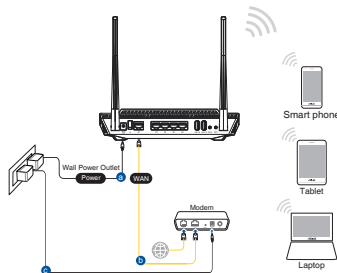

2. Kết nối với tên mạng (SSID) in trên nhãn sản phẩm ở phía sau router. Để bảo mật mạng tốt hơn, hãy đổi sang SSID duy nhất và gán một mật khẩu.



Tên Wi-Fi (SSID): ASUS_XX_2G

- * **XX** đề cập đến hai số cuối của địa chỉ MAC. Bạn có thể tìm thấy nó trên nhãn ở mặt sau router RT-AX56U.

3. Bạn có thể chọn Web GUI hoặc ứng dụng ASUS Router để thiết lập router.

a. Thiết lập Web GUI

- Một khi đã kết nối, GUI web sẽ tự động bật lên khi bạn mở trình duyệt web. Nếu nó không tự động bật lên, hãy nhập <http://router.asus.com>.
- Thiết lập mật khẩu cho router để ngăn chặn truy cập trái phép.

Login Information Setup

Change the router password to prevent unauthorized access to your ASUS wireless router.

Router Login Name	<input type="text" value="admin"/>
New Password	<input type="password"/>
Retype Password	<input type="password"/> <input type="checkbox"/> Show password

b. Thiết lập ứng dụng

Tải về Ứng dụng ASUS Router để thiết lập router của bạn qua các thiết bị di động.

- **Bật Wi-Fi trên các thiết bị di động của bạn và kết nối với mạng của RT-AX56U.**
- **Thực hiện theo các hướng dẫn thiết lập Ứng dụng ASUS Router để hoàn tất quy trình thiết lập.**



ASUS
Router



ASUS Router

Ghi nhớ các cài đặt router không dây của bạn

- **Ghi nhớ các cài đặt không dây khi bạn hoàn tất thiết lập router.**

Tên router:	Mật khẩu:
SSID mạng 2,4 GHz:	Mật khẩu:
SSID mạng 5G Hz:	Mật khẩu:

Hỏi Đáp

1. Tôi có thể tìm thêm thông tin về router không dây ở đâu?
 - Trang Hỏi Đáp trực tuyến: <https://www.asus.com/support/faq>
 - Trang hỗ trợ kỹ thuật: <https://www.asus.com/support>
 - Đường dây nóng khách hàng: Tham khảo phần Đường dây nóng hỗ trợ trong Torr hướng dẫn khởi động nhanh này
 - Bạn có thể truy cập sổ hướng dẫn sử dụng trực tuyến tại <https://www.asus.com/support>

ASUS Recycling/Takeback Services

ASUS recycling and takeback programs come from our commitment to the highest standards for protecting our environment. We believe in providing solutions for you to be able to responsibly recycle our products, batteries, other components, as well as the packaging materials. Please go to <http://csr.asus.com/english/Takeback.htm> for the detailed recycling information in different regions.

REACH

Complying with the REACH (Registration, Evaluation, Authorisation, and Restriction of Chemicals) regulatory framework, we published the chemical substances in our products at ASUS REACH website at <http://csr.asus.com/english/REACH.htm>

Federal Communications Commission Statement

This device complies with Part 15 of the FCC Rules. Operation is subject to the following two conditions:

- This device may not cause harmful interference.
- This device must accept any interference received, including interference that may cause undesired operation.

This equipment has been tested and found to comply with the limits for a class B digital device, pursuant to part 15 of the FCC Rules. These limits are designed to provide reasonable protection against harmful interference in a residential installation. This equipment generates, uses and can radiate radio frequency energy and, if not installed and used in accordance with the instructions, may cause harmful interference to radio communications. However, there is no guarantee that interference will not occur in a particular installation. If this equipment does cause harmful interference to radio or television reception, which can be determined by turning the equipment off and on, the user is encouraged to try to correct the interference by one or more of the following measures:

- Reorient or relocate the receiving antenna.
- Increase the separation between the equipment and receiver.
- Connect the equipment into an outlet on a circuit different from that to which the receiver is connected.
- Consult the dealer or an experienced radio/TV technician for help.



WARNING! Any changes or modifications not expressly approved by the party responsible for compliance could void the user's authority to operate the equipment.

Prohibition of Co-location

This device and its antenna(s) must not be co-located or operating in conjunction with any other antenna or transmitter.

IMPORTANT NOTE:

Radiation Exposure Statement: This equipment complies with FCC radiation exposure limits set forth for an uncontrolled environment. End users must follow the specific operating instructions for satisfying RF exposure compliance. To maintain compliance with FCC exposure compliance requirement, please follow operation instruction as documented in this manual.



WARNING! This equipment must be installed and operated in accordance with provided instructions and the antenna(s) used for this transmitter must be installed to provide a separation distance of at least 24 cm from all persons and must not be co-located or operating in conjunction with any other antenna or transmitter.

KC: Korea Warning Statement

B급 기기 (가정용 방송통신기자재)	이 기기는 가정용(B급)으로 전자파적합등록을 한 기기로서 주로 가정에서 사용하는 것을 목적으로 하며, 모든 지역에서 사용할 수 있습니다.
Class B equipment (For Home Use Broadcasting & Communication Equipment)	This equipment is home use (Class B) electromagnetic wave suitability and to be used mainly at home and it can be used in all areas.

India RoHS

This product complies with the "India E-Waste (Management) Rules, 2016" and prohibits use of lead, mercury, hexavalent chromium, polybrominated biphenyls(PBBs) and polybrominated diphenyl ethers (PBDEs) in concentrations exceeding 0.1 % by weight in homogenous materials and 0.01 % by weight in homogenous materials for cadmium, except for the exemptions listed in Schedule II of the Rule.

NCC 警語

經型式認證合格之低功率射頻電機，非經許可，公司、商號或使用者均不得擅自變更頻率、加大功率或變更原設計之特性及功能。低功率射頻電機之使用不得影響飛航安全及干擾合法通信；經發現有干擾現象時，應立即停用，並改善至無干擾時方得繼續使用。前項合法通信，指依電信法規定作業之無線電通信。低功率射頻電機須忍受合法通信或工業、科學及醫療用電波輻射性電機設備之干擾。

「產品之限用物質含有情況」之相關資訊，請參考下表：

單元	限用物質及其化學符號					
	鉛 (Pb)	汞 (Hg)	鎘 (Cd)	六價鉻 (Cr ⁶⁺)	多溴聯苯 (PBB)	多溴二苯醚 (PBDE)
印刷電路板及電子組件	-	○	○	○	○	○
結構組件（金屬 / 塑膠）	○	○	○	○	○	○
其他組件（如天線 / 指示燈 / 連接線）	○	○	○	○	○	○
其他及其配件（如電源供應器）	-	○	○	○	○	○

備考1. “○” 係指該項限用物質之百分比含量未超出百分比含量基準值。
備考2. “-” 係指該項限用物質為排除項目。

MPE

本產品電磁波曝露量 (MPE) 標準值 $1\text{mW}/\text{cm}^2$ ，送測產品實測值為 $0.48236\text{mW}/\text{cm}^2$ ，建議使用時至少距離人體 24cm。

安全說明：

- 請在溫度為0°C (32°F)至40°C (104°F)之間的環境中使用本產品
- 請依照產品上的電源功率貼紙說明使用正確的電源變壓器,如果使用錯誤規格的電源變壓器有可能會造成內部零件的損壞
- 請勿將產品放置於不平坦或不穩定的表面,若產品的機殼毀損,請聯絡維修服務人員
- 請勿在產品上放置其他物品,請勿將任何物品塞入產品內,以避免引起元件短路或電路損毀
- 請保持機器在乾燥的環境下使用,雨水、溼氣、液體等含有礦物質將會腐蝕電子線路,請勿在雷電天氣下使用數據機。
- 請勿堵塞產品的通風孔,以避免因散熱不良而導致系統過熱。
- 請勿使用破損的電源線,附件或其他周邊產品。
- 如果電源已毀損,請不要嘗試自行修復,請將其交給專業技術服務人員或經銷商來處理
- 為了防止電擊風險,在搬動主機之前,請先將電源線插頭暫時從電源插座上拔除



电子电气产品有害物质限制使用标识要求：图中之数字为产品之环保使用期限。仅指电子电气产品中含有的有害物质不致发生外泄或突变从而对环境造成污染或对人体、财产造成严重损害的期限。

产品中有害物质的名称及含量

部件名称	有害物质					
	铅(Pb)	汞(Hg)	镉(Cd)	六价铬(Cr(VI))	多溴联苯(PBB)	多溴二苯醚(PBDE)
印刷电路板及其电子组件	×	○	○	○	○	○
外壳	○	○	○	○	○	○
电源适配器	×	○	○	○	○	○
外部信号连接头及线材	×	○	○	○	○	○
中央处理器与内存	×	○	○	○	○	○

本表格依据 SJ/T 11364 的规定编制。

○：表示该有害物质在该部件所有均质材料中的含量均在 GB/T 26572 规定的限量要求以下。

×：表示该有害物质至少在该部件的某一均质材料中的含量超出 GB/T 26572 规定的限量要求，然该部件仍符合欧盟指令 2011/65/EU 的规范。

备注：此产品所标示之环保使用期限，系指在一般正常使用状况下。

安全说明：

- 请在温度为 0° C (32° F) 至 40° C (104° F) 之间的环境中使用本产品。
- 请依照产品上的电源功率贴纸说明使用正确的电源适配器，如果试用错误规格的电源适配器可能会造成内部零件的损坏。
- 请勿将产品放置于不平坦或不稳定的表面，若产品的外壳损坏，请联系维修服务人员。
- 请勿在产品上放置其他物品，请勿将任何物品塞入产品内，以避免引起组件短路或电路损坏。
- 请保持机器在干燥的环境下使用，雨水、湿气、液体等含有矿物质会腐蚀电子线路，请勿在雷电天气下使用调制解调器。
- 请勿堵塞产品的通风孔，以避免因散热不良而导致系统过热。
- 请勿使用破损的电源线、附件或其他周边产品。
- 如果电源已损坏，请不要尝试自行修复，请将其交给专业技术服务人员或经销商来处理。
- 为了防止电击风险，在搬动主机前，请先将电源线插头暂时从电源插座上拔除。

华硕的联络信息

华硕电脑（上海）有限公司 ASUSTEK COMPUTER
(SHANGHAI) CO., LTD（中国）

市场信息

地址：上海市闵行区金都路 5077 号
电话：+86-21-54421616
传真：+86-21-54420088
互联网：<https://www.asus.com.cn/>

技术支持

电话：400-620-6655
电子邮件：<https://vip.asus.com/VIP2/Services/TechQuery?lang=zh-cn>

华硕电脑公司 ASUSTeK COMPUTER INC.（亚太地区）

市场信息

地址：台湾台北市北投区立德路 15 号
电话：+886-2-2894-3447
传真：+886-2-2890-7798
电子邮件：info@asus.com.tw
互联网：<https://www.asus.com/tw>

技术支持

电话：+86-21-38429911
传真：+86-21-58668722, ext. 9101#
在线支持：<https://www.asus.com/tw/support/>

Manufacturer: **ASUSTeK Computer Inc.**

Tel: +886-2-2894-3447

Address: 4F, No. 150, LI-TE RD., PEITOU, TAIPEI 112, TAIWAN

華碩電腦股份有限公司

電話：+886-2-2894-3447

地址：台灣台北市北投區立德路15號

Networks Global Hotline Information

Area	Country/ Region	Hotline Number	Service Hours
Europe	Cyprus	800-92491	09:00-13:00 ; 14:00-18:00 Mon-Fri
	France	0033-170949400	09:00-18:00 Mon-Fri
	Germany	0049-1805010920	09:00-18:00 Mon-Fri 10:00-17:00 Mon-Fri
		0049-1805010923 (component support)	
		0049-2102959911 (Fax)	
	Hungary	0036-15054561	09:00-17:30 Mon-Fri
	Italy	199-400089	09:00-13:00 ; 14:00-18:00 Mon-Fri
	Greece	00800-44142044	09:00-13:00 ; 14:00-18:00 Mon-Fri
	Austria	0043-820240513	09:00-18:00 Mon-Fri
	Netherlands/ Luxembourg	0031-591570290	09:00-17:00 Mon-Fri
	Belgium	0032-78150231	09:00-17:00 Mon-Fri
	Norway	0047-2316-2682	09:00-18:00 Mon-Fri
	Sweden	0046-858769407	09:00-18:00 Mon-Fri
	Finland	00358-969379690	10:00-19:00 Mon-Fri
	Denmark	0045-38322943	09:00-18:00 Mon-Fri
	Poland	0048-225718040	08:30-17:30 Mon-Fri
	Spain	0034-902889688	09:00-18:00 Mon-Fri
	Portugal	00351-707500310	09:00-18:00 Mon-Fri
	Slovak Republic	00421-232162621	08:00-17:00 Mon-Fri
	Czech Republic	00420-596766888	08:00-17:00 Mon-Fri
Switzerland-German	0041-848111010	09:00-18:00 Mon-Fri	
Switzerland-French	0041-848111014	09:00-18:00 Mon-Fri	
Switzerland-Italian	0041-848111012	09:00-18:00 Mon-Fri	
United Kingdom	0044-1442265548	09:00-17:00 Mon-Fri	
Ireland	0035-31890719918	09:00-17:00 Mon-Fri	
Russia and CIS	008-800-100-ASUS	09:00-18:00 Mon-Fri	
Ukraine	0038-0445457727	09:00-18:00 Mon-Fri	

Networks Global Hotline Information

Area	Country/ Region	Hotline Numbers	Service Hours
Asia-Pacific	Australia	1300-278788	09:00-18:00 Mon-Fri
	New Zealand	0800-278788	09:00-18:00 Mon-Fri
	Japan	0800-1232787	09:00-19:00 Mon-Sun
		0081-570783886 (Non-Toll Free)	09:00-19:00 Mon-Sun
	Korea	0082-215666868	09:30-17:00 Mon-Fri
	Thailand	0066-24011717	09:00-18:00 Mon-Fri
		1800-8525201	
	Singapore	0065-64157917	11:00-19:00 Mon-Fri
		0065-67203835 (Repair Status Only)	11:00-19:00 Mon-Fri 11:00-13:00 Sat
	Malaysia	1300-88-3495	9:00-18:00 Mon-Fri
	Philippine	1800-18550163	09:00-18:00 Mon-Fri
	India	1800-2090365	09:00-18:00 Mon-Sat
	India(WL/NW)		09:00-21:00 Mon-Sun
	Indonesia	0062-2129495000	09:30-17:00 Mon-Fri
500128 (Local Only)		9:30 – 12:00 Sat	
Vietnam	1900-555581	08:00-12:00 13:30-17:30 Mon-Sat	
Hong Kong	00852-35824770	10:00-19:00 Mon-Sat	
Taiwan	0800-093-456; 02-81439000	9:00-12:00 Mon-Fri; 13:30-18:00 Mon-Fri	
Americas	USA	1-812-282-2787	8:30-12:00 EST Mon-Fri
	Canada		9:00-18:00 EST Sat-Sun
	Mexico	001-8008367847	08:00-20:00 CST Mon-Fri 08:00-15:00 CST Sat
	Brazil	4003 0988 (Capital) 0800 880 0988 (demais localidades)	9:00am-18:00 Mon-Fri

Networks Global Hotline Information

Area	Country/ Region	Hotline Numbers	Service Hours
Middle East + Africa	Egypt	800-2787349	09:00-18:00 Sun-Thu
	Saudi Arabia	800-1212787	09:00-18:00 Sat-Wed
	UAE	00971-42958941	09:00-18:00 Sun-Thu
	Turkey	0090-2165243000	09:00-18:00 Mon-Fri
	South Africa	0861-278772	08:00-17:00 Mon-Fri
	Israel	*6557/00972-39142800 *9770/00972-35598555	08:00-17:00 Sun-Thu 08:30-17:30 Sun-Thu
Balkan Countries	Romania	0040-213301786	09:00-18:30 Mon-Fri
	Bosnia Herzegovina	00387-33773163	09:00-17:00 Mon-Fri
	Bulgaria	00359-70014411 00359-29889170	09:30-18:30 Mon-Fri 09:30-18:00 Mon-Fri
	Croatia	00385-16401111	09:00-17:00 Mon-Fri
	Montenegro	00382-20608251	09:00-17:00 Mon-Fri
	Serbia	00381-112070677	09:00-17:00 Mon-Fri
	Slovenia	00368-59045400 00368-59045401	08:00-16:00 Mon-Fri
Baltic Countries	Estonia	00372-6671796	09:00-18:00 Mon-Fri
	Latvia	00371-67408838	09:00-18:00 Mon-Fri
	Lithuania-Kaunas	00370-37329000	09:00-18:00 Mon-Fri
	Lithuania-Vilnius	00370-522101160	09:00-18:00 Mon-Fri



NOTES:

- UK support e-mail: network_support_uk@asus.com
- For more information, visit the ASUS support site at: <https://www.asus.com/support/>

CE statement

Simplified EU Declaration of Conformity

ASUSTek Computer Inc. hereby declares that this device is in compliance with the essential requirements and other relevant provisions of Directive 2014/53/EU. Full text of EU declaration of conformity is available at https://www.asus.com/Networking/RT-AX56U/HelpDesk_Declaration/.

Declaration of Conformity for Ecodesign directive 2009/125/EC

Testing for eco-design requirements according to (EC) No 1275/2008 and (EU) No 801/2013 has been conducted. When the device is in Networked Standby Mode, its I/O and network interface are in sleep mode and may not work properly. To wake up the device, press the WPS button.

This equipment complies with EU radiation exposure limits set forth for an uncontrolled environment. This equipment should be installed and operated with minimum distance 24 cm between the radiator & your body.

All operational modes:

2.4GHz: 802.11b, 802.11g, 802.11n (HT20), 802.11n (HT40), 802.11ac (VHT20), 802.11ac (VHT40), 802.11ax (HE20), 802.11ax(HE40)

5GHz: 802.11a, 802.11n (HT20), 802.11n (HT40), 802.11ac (VHT20), 802.11ac (VHT40), 802.11ac (VHT80), 802.11ax (HE20), 802.11ax(HE40), 802.11ax (HE80)

The frequency, mode and the maximum transmitted power in EU are listed below:

2412-2472MHz (802.11g 6 Mbps): 19.96 dBm

5180-5240MHz (802.11ac VHT20 MCS0): 22.97 dBm

5260-5320MHz (802.11ac VHT40 MCS0): 22.97 dBm

5500-5700MHz (802.11ac VHT80 MCS0): 29.98 dBm

The device is restricted to indoor use only when operating in the 5150 to 5350 MHz frequency range. The adapter shall be installed near the equipment and shall be easily accessible.

	AT	BE	BG	CZ	DK	EE	FR
	DE	IS	IE	IT	EL	ES	CY
	LV	LI	LT	LU	HU	MT	NL
	NO	PL	PT	RO	SI	SK	TR
	FI	SE	CH	UK	HR	UA	

Safety Notices

- Use this product in environments with ambient temperatures between 0°C(32°F) and 40°C(104°F).
- Refer to the rating label on the bottom of your product and ensure your power adapter complies with this rating.
- DO NOT place on uneven or unstable work surfaces. Seek servicing if the casing has been damaged.
- DO NOT place or drop objects on top and do not shove any foreign objects into the product.
- DO NOT expose to or use near liquids, rain, or moisture. DO NOT use the modem during electrical storms.
- DO NOT cover the vents on the product to prevent the system from getting overheated.
- DO NOT use damaged power cords, accessories, or other peripherals.
- If the Adapter is broken, do not try to fix it by yourself. Contact a qualified service technician or your retailer.
- To prevent electrical shock hazard, disconnect the power cable from the electrical outlet before relocating the system.
- DO NOT mount this equipment higher than 2 meters.